

Starlink[®] Dish Mounting Kit

Assembly

There are two methods for attaching your SeaSucker vacuum mounts to your Starlink Dish Mounting Kit for the Starlink Flat High Performance Dish.

Method 1: with Wedge Mount. Turn your dish face down. Position a vacuum mount over one of the mounting holes on the Wedge Mount with the pump facing out towards the edge of the dish. Push the vacuum mount's threaded stud through the hole. Place a washer and nut on the stud and tighten securely with a 7/16" wrench. Repeat for the remains three vacuum mounts. Pro tip: it may be easier to remove the Wedge Mount, attach the vacuum mounts to it, and then reattach the Wedge Mount.

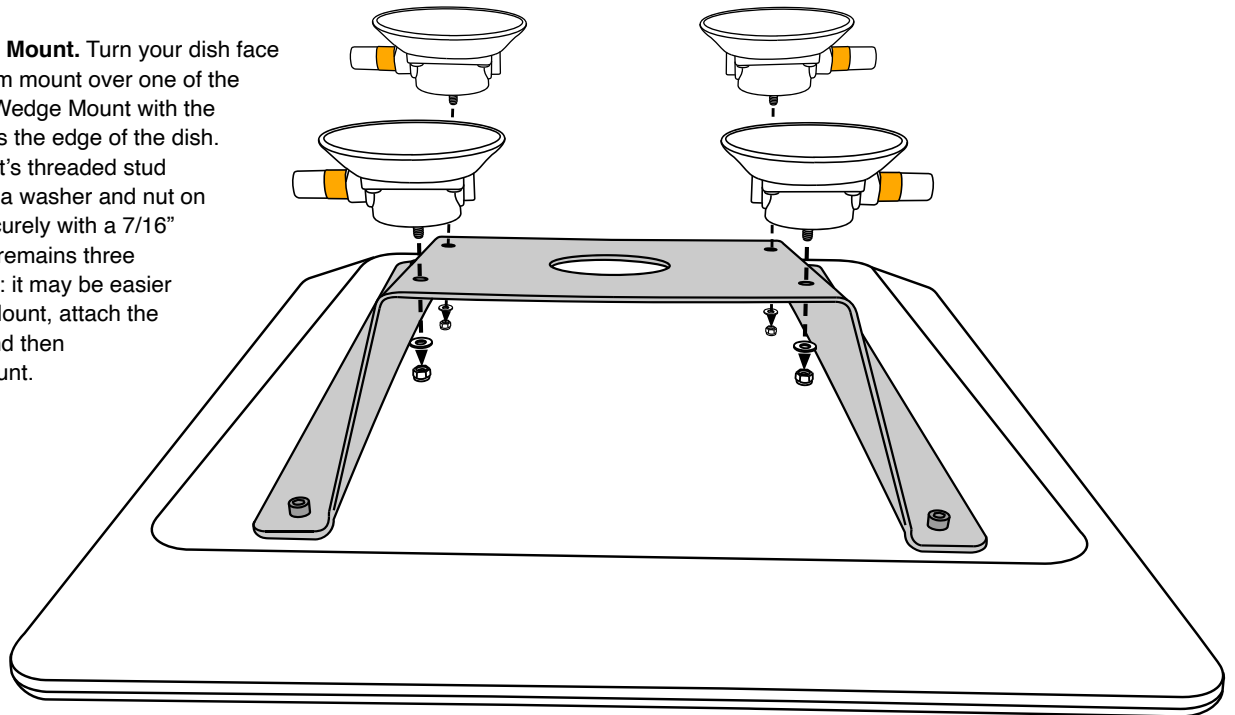

Method 2: no Wedge Mount. Turn your dish face down. If attached, remove the Wedge Mount. Position the Wedge Mount's orange and black washers over the threaded hole and then screw the stud on top of the vacuum mount into the threaded hole. Spin the vacuum mount on until secure. Do not over-tighten. Repeat for the other three vacuum mounts and inserts

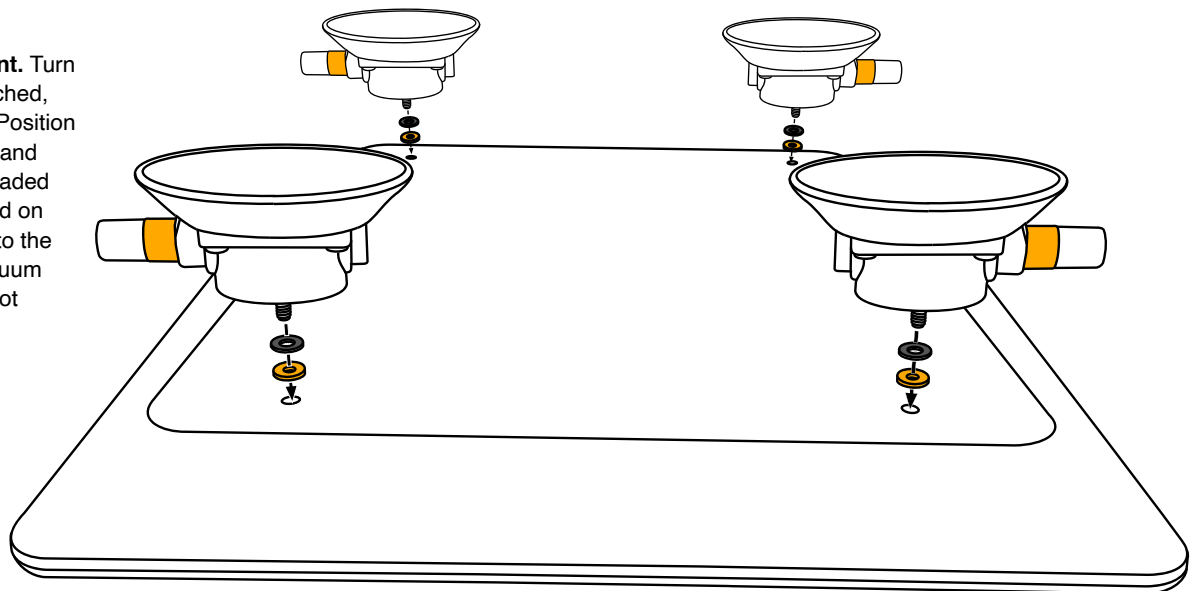

Designed and manufactured by:
SeaSucker, LLC
Bradenton, Florida
www.SeaSucker.com

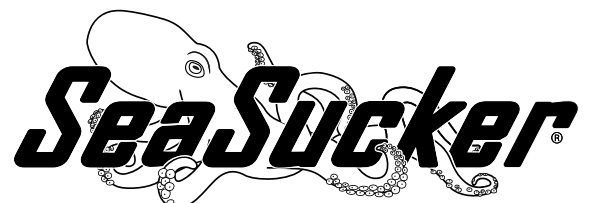

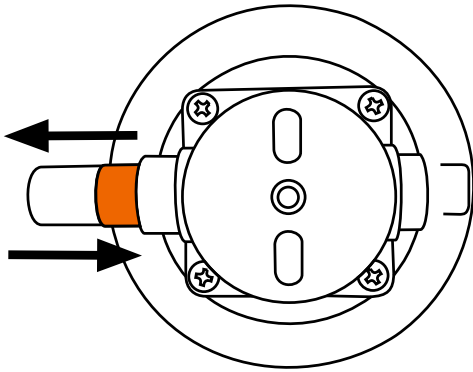

Attaching Your Starlink Dish Mounting Kit

Your Starlink Dish Mounting Kit should be attached to a clean, unobstructed metal, glass, fiberglass, carbon fiber, or other rigid, non-porous surface. The vacuum mount will not attach over a seam or other surface incongruity.

- **DO NOT** attach in a position that interferes with the driver's visibility.
- **DO NOT** attach over decals or wraps.

Please review the Important Warnings on the last page of these instructions.

Clean the surface you're going to mount your dish to. Dust and dirt will affect the vacuum mounts' ability to create and hold vacuum. Remove the protective covers from the vacuum mounts and inspect the rubber vacuum pads for damage or dirt. Do not use a vacuum mount with any visible damage to the vacuum pad. If a vacuum pad is dirty, clean it with a mild soap and water solution and a soft cloth or sponge.

It may help to moisten the bottom edge of the vacuum pads with water - do not use cleaners, lubricants or other liquids.

Press the vacuum mounts against the mounting surface to make a full seal; you may need to press firmly down to ensure that the vacuum pads are fully connecting with the mounting surface when pumping.

Pump repeatedly until the plunger doesn't spring back and the indicator band is hidden inside the pump cylinder. Repeat for all other vacuum mounts. If a plunger won't stay seated in the pump cylinder or continues to extend out immediately after pumping, you may need to clean the mounting surface or the vacuum pad or pump, perform basic maintenance on the vacuum pad or pump, or move to a more suitable mounting position. Do not use your dish mount without correcting the problem!

Removing Your Starlink Dish Mounting Kit: Lift and Cover

With your fingertip, use one of the tabs on a vacuum pad to lift the edge of the pad up from the mounting surface and break the vacuum seal. Repeat for the other vacuum mounts.

Always put the protective cover backs on when the dish is not attached to protect the vacuum pads. Make sure each pad is fully seated in its protective cover before storing it. The edge of the vacuum pad could be damaged or deformed if the vacuum pad isn't fully seated in the protective cover.

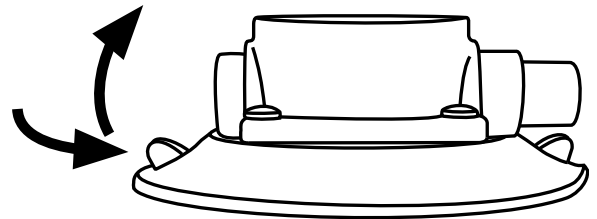

Check for the Indicator Band During Use

SeaSucker vacuum mounts are not intended to be permanent fixtures on - they will lose vacuum over time. When your vacuum mount loses vacuum, it will warn you by extending the pump's plunger, exposing an orange band. You are required to monitor your vacuum mount during use. Check regularly to see if the indicator band is visible on the vacuum mount. If you see the band, simply pump the SeaSucker as described above.

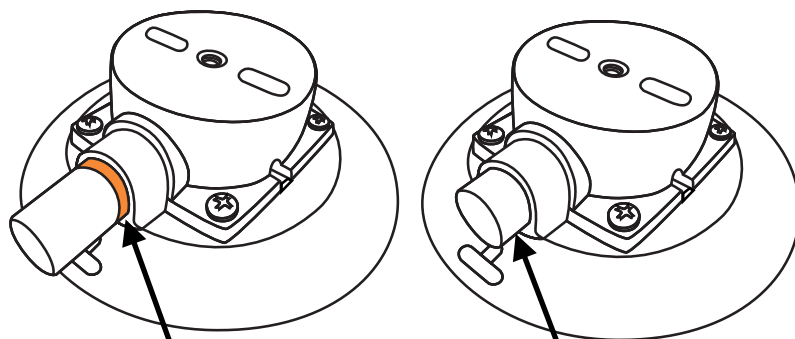

**Indicator band exposed:
time to re-pump!**

Full power!

If the indicator band appears less than four hours after being pumped to full strength, either cleaning, maintenance or repositioning may be required. Refer to the Troubleshooting Guide at the end of these instructions. If your Starlink Dish Mounting Kit is mounted on a scratched surface, move it to a more suitable position. If the mounting surface or vacuum mount is dirty, clean it. If these steps don't stop the vacuum mount from losing vacuum prematurely, discontinue use until the problem is resolved. Replace the pump on the suspect vacuum mount if necessary - replacement parts can be purchased in the Replacement Parts section of our on-line store.

Repair and Replacement

Products with non-warrantable damage may still be repaired or replaced at your expense. Discounted replacement parts, including vacuum pads and pumps can be found on-line in the Replacement Parts section of SeaSucker's on-line store at www.seasucker.com.

Care and Maintenance

To get the most out of your vacuum mounts, inspect each vacuum mount regularly and store it with its protective cover on. Check that all screws are securely tightened, including the screws attaching the vacuum pad to the housing.

Clean the vacuum pads before each use with a sponge or soft cloth, mild dish soap and water. Do not use harsh solvents or abrasive cleaning pads. Inspect the sealing edges for stiffness, cracks, roughness, or cuts. A damaged vacuum pad should be replaced.

The vacuum pumps should be cleaned regularly. Pull the plunger straight out of the pump cylinder. Clean the inside of the cylinder with dish soap and a soft cloth or paper towel. Dry the inside of the cylinder – water left in the cylinder may interfere with the check-valve function of the pump.

The plungers should be wiped clean and the black rubber seals at the tip of the plungers should be re-lubed with a thin layer of silicone-based gel lubricant, such as the Lube Tube brand lubricant. After cleaning, push the plunger back into the cylinder and pump it several times to seat it properly and distribute the lubricant.

Warranty

SeaSucker offers a lifetime, non-transferable warranty to the original purchaser covering defects in materials and workmanship. Defective products can be returned to SeaSucker for replacement or repair (at SeaSucker’s option). Warranty claims must be accompanied by a sales receipt or other proof of purchase document. The cost of transportation to and from SeaSucker for the repair or replacement of any defective part or accessory is not covered by this warranty and is to be paid by the owner.

This warranty does not apply to damage or failure resulting from routine wear and tear expected in the normal use of this product, or to lack of maintenance, user error, alteration or modification of the product, accidents, misuse, abuse, or neglect.

This warranty is given in lieu of all other written or oral warranties, express or implied, including without limitation implied warranties of merchantability and fitness for a particular purpose, and are limited to the duration and specifications of this warranty.

Purchaser’s exclusive remedy under this warranty is the repair or replacement of a defective product or, at SeaSucker’s option, the issuance of a refund or credit for the purchase price of the product. SeaSucker’s liability for any damages relating to any allegedly defective product, whether arising from the use or the inability to use the product and whether claimed under tort, contract or any other legal theory, shall be limited to the actual price paid for such product and shall in no event include loss of use, loss of time, incidental, consequential, special, or indirect damages of any kind, even if SeaSucker is aware of the possibility of such damages, to the full extent as such may be disclaimed by law.

IMPORTANT WARNINGS

- Do not use if the indicator band is exposed on any vacuum mount’s pump.
- Do not use if any vacuum mount cannot maintain a full vacuum seal for at least 4 hours.
- Clean the mounting surface before attaching.
- Clean vacuum mounts before attaching.
- Clean and lube the vacuum mounts’ pumps regularly.
- Inspect screws, nuts, and bolts regularly and retighten if necessary.
- Make sure the vacuum pads are fully seated in the protective covers when not in use.

TROUBLESHOOTING GUIDE	Problem	What Might Be Wrong	How To Fix It
	Slow Leakage	Dry mounting surface or vacuum pad	Moisten the mounting surface or the vacuum pad
		Nicks or cuts on vacuum pad	Replace the vacuum pad
		Dirt in pump	Clean and re-lube the plunger and pump cylinder
		Dry pump	Re-lube the plunger seal
		Dirt on vacuum pad	Clean the vacuum pad
		Dirty or uneven mounting surface	Clean the mounting surface or move to a more suitable spot
	Severe Leakage	Nicks or cuts on vacuum pad	Replace the vacuum pad
		Damaged pump	Replace the vacuum pump
		Dirty or uneven mounting surface	Clean the mounting surface or move to a more suitable spot
Jammed or Sluggish Pump	Dry pump	Re-lube the plunger seal	
	Obstructed valve stem	Remove the obstruction; clean and re-lube the pump	
	Dirt in pump	Clean and re-lube the plunger and pump cylinder	