

QUICKPLAY[®]

BALLER MINI HOOP SYSTEM



**PLEASE SAVE THIS MANUAL
IN THE EVENT THAT YOU
NEED TO CONTACT US FOR
REPLACEMENT PARTS.**

SAFETY INSTRUCTIONS & BEFORE YOU BEGIN:

Failure to follow these safety instructions may result in serious injury or property damage and will void warranty.

To ensure safety, do not attempt to assemble the BALLER MINI HOOP SYSTEM without following the enclosed instructions carefully. Before beginning assembly, read the instructions and identify parts and hardware using the parts list enclosed. If any parts are missing, please contact customer service before proceeding with assembly.

Proper and complete assembly, use and supervision are essential for proper operation and to reduce the risk of accident or injury. A high probability of injury exists if this system is not assembled, maintained and operated properly.

Always inspect the product prior to and after each use. If you find any flaw or defect, do not use the BALLER MINI HOOP SYSTEM and contact Customer Service for a replacement part: info@quickplaysport.com

WARNINGS:

1. Must be assembled by an adult.
2. Read and understand all warning labels affixed to the product and within this instruction manual.
3. Use under adult supervision. This product is not suitable for children under 3 years of age.
4. Only use on a flat smooth surface, which is free of gravel or other objects.
5. Check the BALLER MINI HOOP SYSTEM is fully and properly assembled before use.
6. Check the Base is fully filled with sand or water before use. Check Base daily for leakage. Slow leaks can cause the unit to tip over more easily.
7. If using water in sub-freezing climates, add 1/2 gallon of non-toxic antifreeze to the Base before filling.
8. Do not slide, stand, jump, climb or play on the Base or Post.
9. BALLER MINI HOOP SYSTEM is intended for home, recreational play only and is not intended for excessive competitive use.
10. Do not climb on or hang on rim of the BALLER MINI HOOP SYSTEM.
11. During play, especially when performing dunk-type moves, ensure players face is kept away from the backboard, rim and net. Serious injury could occur if teeth/face come in contact with backboard, rim or net.
12. Use caution when using this system. Most injuries are caused by misuse and/or not following instructions.
13. Regularly check for wear and tear. Stop using if any part breaks or shows signs of damage from use or the environment (e.g. rust). Failure to do so may result in injury.
14. To increase the lifespan of your BALLER MINI HOOP SYSTEM keep in a garage or storage shed if possible, especially during winter months or planned non-use.
15. Do not leave the ball outdoors. Exposure to sun, rain and extreme temperatures will shorten its lifespan. Ball is not covered under the product warranty.
16. Not suitable for use in high winds or severe weather.
17. If technical assistance is required, please contact Customer Service via email: info@quickplaysport.com

PARTS:

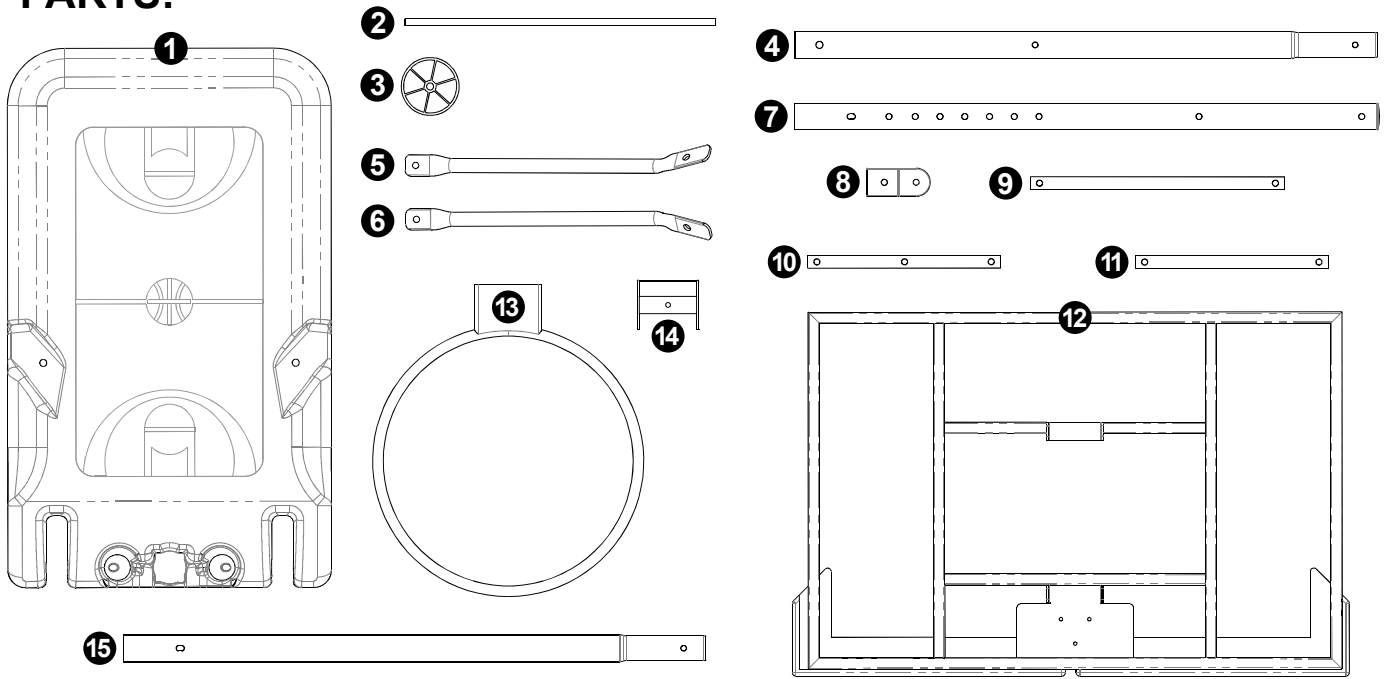

- | | | |
|-----------------------|---------------------------------------|---------------------------------------|
| 1. Base | 6. Right Support Strut | 11. Upper Backboard Support Pole (x2) |
| 2. Axle | 7. Upper Post | 12. Backboard |
| 3. Wheel (x2) | 8. Height Adjust Collar | 13. Rim |
| 4. Lower Post | 9. Height Adjust Pole | 14. Rim Plate |
| 5. Left Support Strut | 10. Lower Backboard Support Pole (x2) | 15. Middle Post |
| | | 16. Net (not shown above) |

HARDWARE SETS:

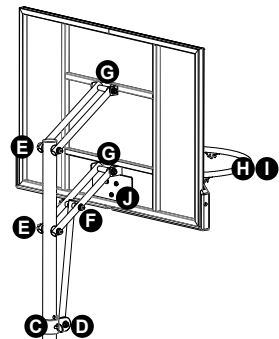
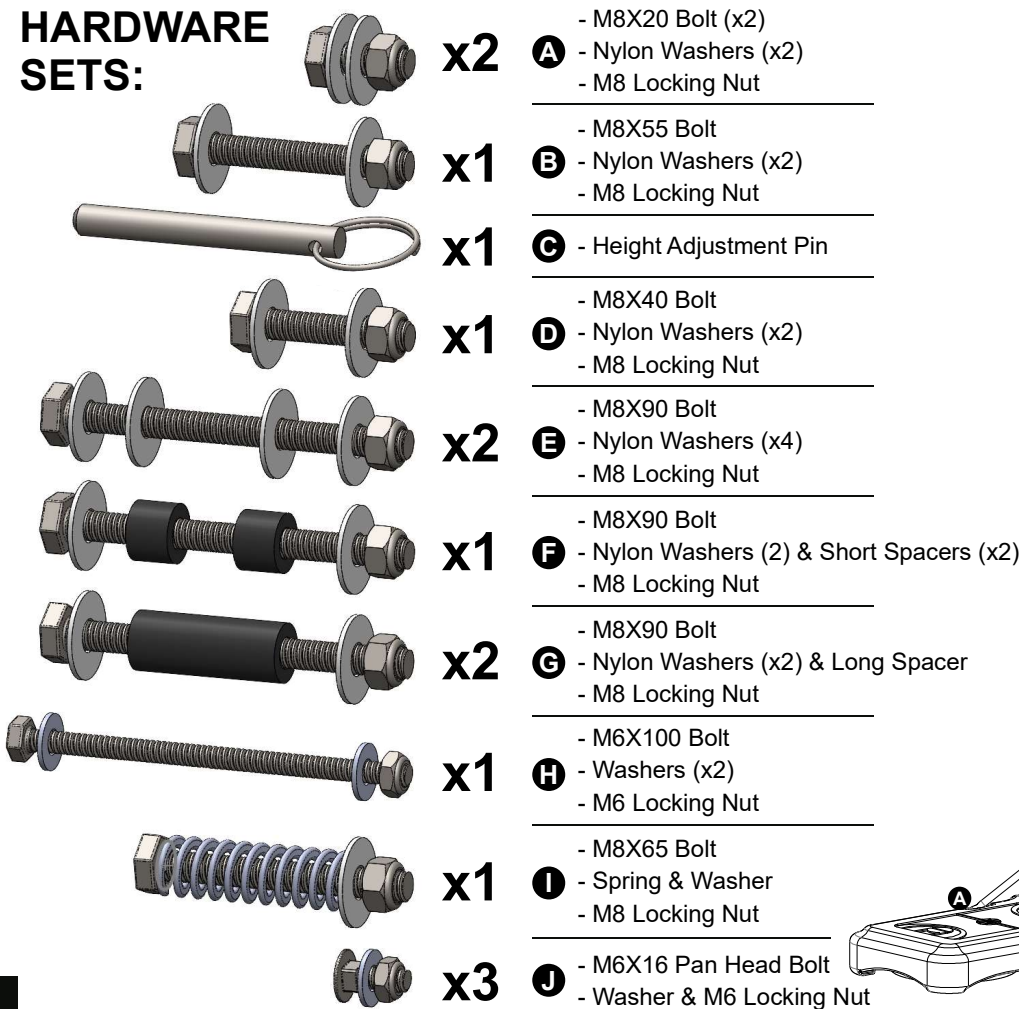

YOU WILL NEED FOR ASSEMBLY:

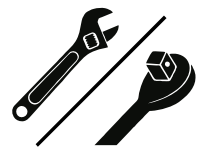

x2 ADJUSTABLE WRENCHES AND/OR SOCKET WRENCHES



SAND AND/OR WATER

REGISTER YOUR WARRANTY:

The BALLER MINI HOOP SYSTEM is covered by a 1 YEAR Limited Parts Warranty. This warranty does not cover the mini basketball provided with the unit, general wear and tear, or damage resulting from accident, misuse, abuse or lost parts. You can extend your 1YR warranty to 2YRS if you register within 15 days of purchase. Visit: Warranty.QuickPlaySport.com or scan this QR code >



HEIGHT ADJUSTMENT OF THE RIM / BACKBOARD:

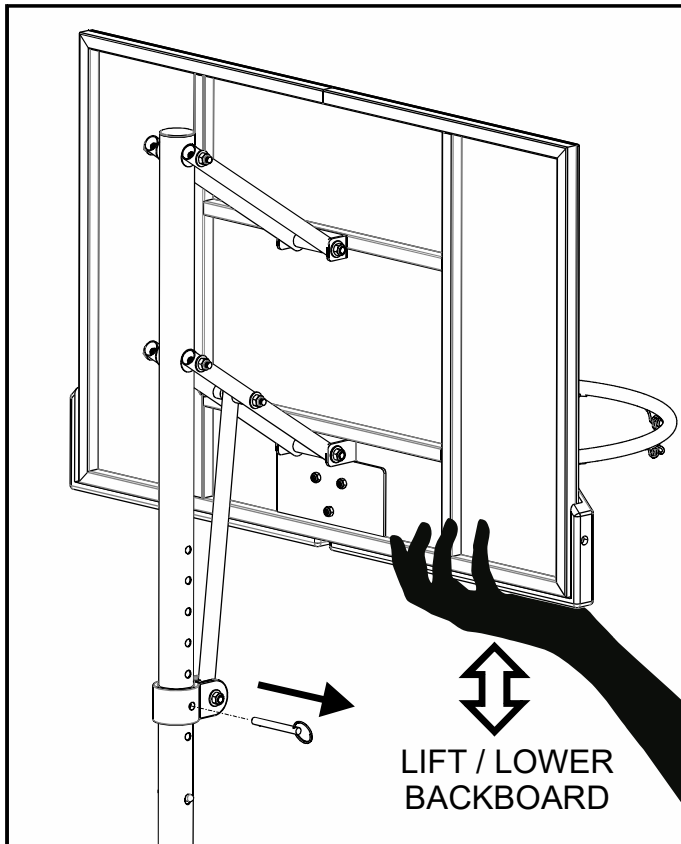

WARNINGS: Height adjustment must be carried out by an adult. Take care when adjusting the height, moving parts may cause entrapment if these instructions are not followed. Do not allow children to move or adjust the height of the system.

When adjusting height or moving the system. Keep hands and fingers away from moving parts.

Always ensure that you support the weight of the backboard during height adjustment. Do not remove the pin without first supporting the backboard weight, doing so may cause the backboard to fall in an uncontrolled manner.

1. Support the weight of the backboard with one hand, by holding the black plastic bumpers.
2. Remove the height adjust pin.
3. Lift or lower the backboard to the desired position.
4. Insert the height adjust pin in the nearest hole.
5. Ensure the pin is fully inserted through both sides of the Height Adjust Collar before play.

MOVING THE BALLER MINI HOOP SYSTEM:

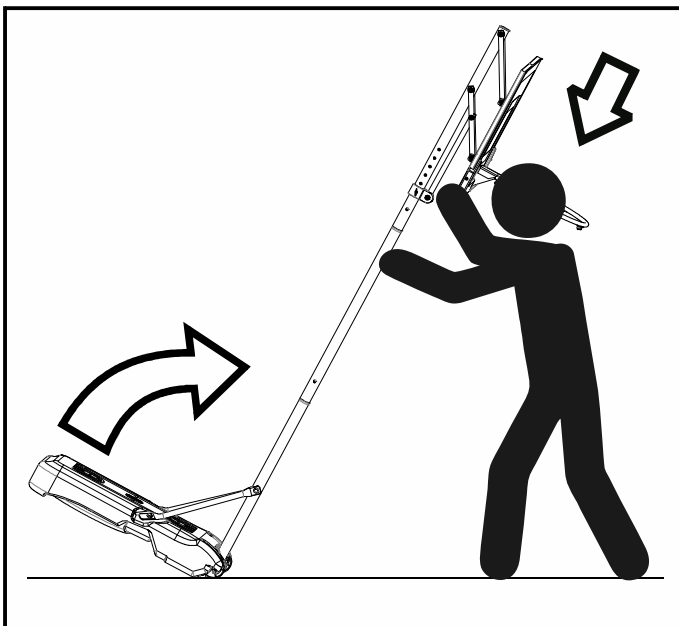

1. Lower the Rim to its lowest height position using the above instructions.
2. Holding the pole and lower edge of the backboard with two hands, tilt the unit forward until the wheels contact the ground.
3. Move the System to the new location, taking care to ensure that the Base does not scrape / catch on the ground.
4. Slowly lower the base down until the pole is upright.

IMPORTANT: After moving the BALLER MINI HOOP SYSTEM make sure the base is level and the System is stable before play.

ASSEMBLY INSTRUCTIONS

STEP A: ASSEMBLE THE BASE

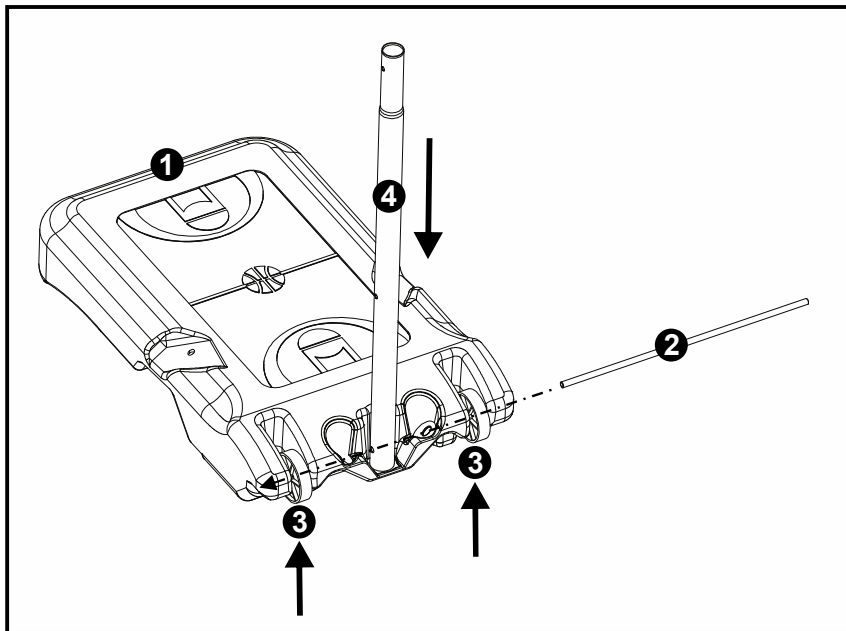

IMPORTANT: Do not fill the base before completing STEP A.

1. Lay the Base (1) on a flat level surface.
2. Slide the Axel (2) through the groove in the Base (1) and the first Wheel (3).
3. Place the Lower Post (4) in the center and slide the Axel (2) through the lowest hole.
4. Continue pushing the Axel (2) through the second wheel (3). Ensure the Axel (2) is centered before continuing.

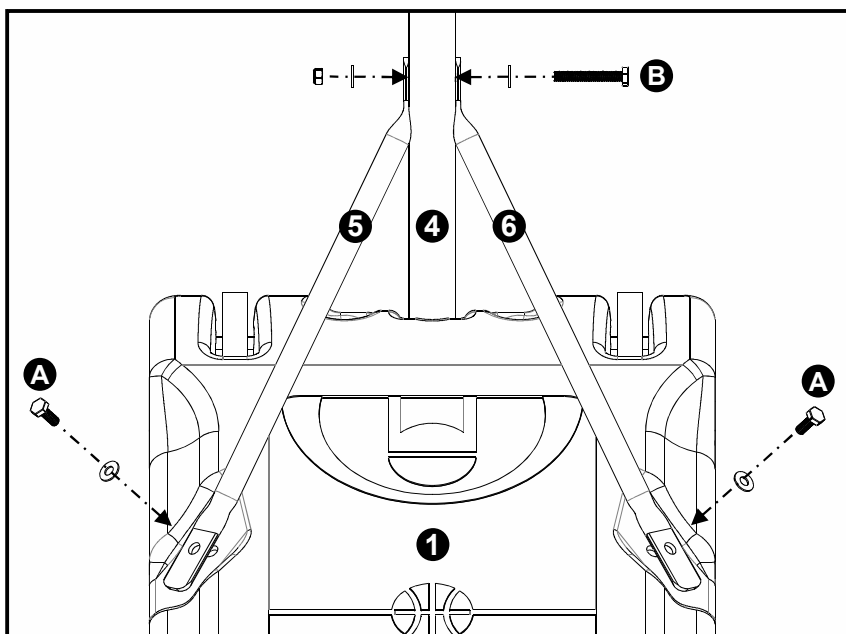
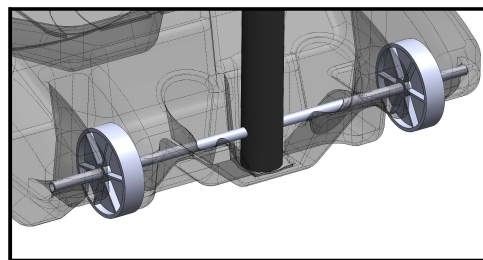

5. Attach the Left & Right Support Struts (5 & 6) to the Base (1) using hardware set (A) and Lower Post (4) using hardware set (B).

- **IMPORTANT:** Orientate the Struts (5 & 6) so the flat ends are flush with both the Base (1) and Lower Post (4) as shown. If struts do not look flush, flip/rotate until they are orientated correctly.

6. Fill the base with sand or water.

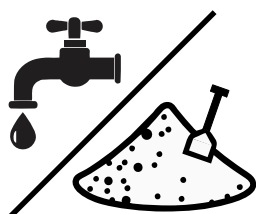
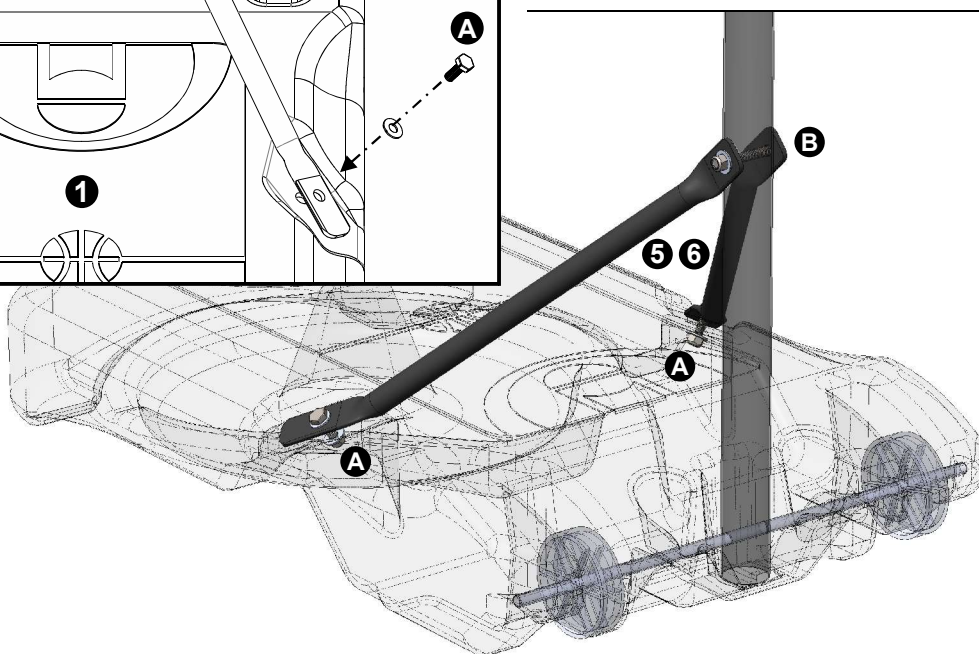

IMPORTANT: AFTER STEP A IS COMPLETE, FILL THE BASE WITH WATER / SAND.

STEP B: ASSEMBLE THE HEIGHT ADJUSTMENT SYSTEM

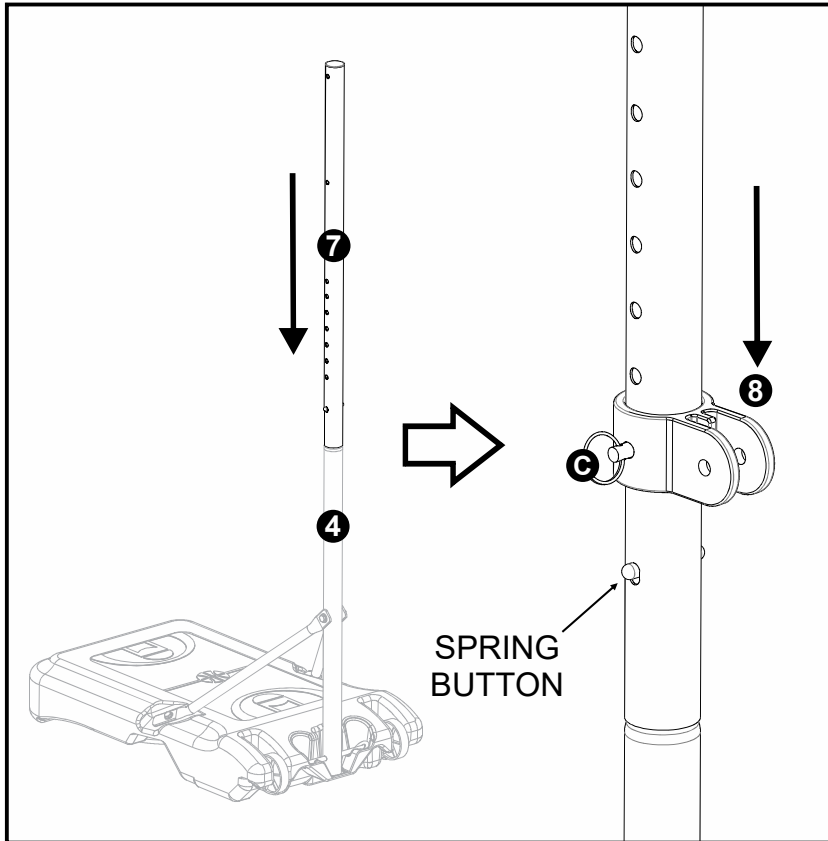

IMPORTANT: Ensure to have filled the base with water / sand before continuing.

1. Connect the Upper post (7) onto the Lower Post (4) and locate with the integrated spring buttons. **NOTE:** Do not add the Middle Post (15) at this time. This part can be added at the end of the assembly process if required.
2. Slide the Height Adjust Collar (8) onto the Upper Post (7) and locate in the lowest hole with the Height Adjustment Pin, hardware set (C).



3. Attach the Height Adjust Collar (8) to the Height Adjust Pole (9) with hardware set (D).
4. Attach the x2 Lower Backboard Support Poles (10) to the Upper Post (7) with hardware set (E).
5. Attach the Lower Backboard Support Poles (10) to the Height Adjust Pole (9) with hardware set (F).

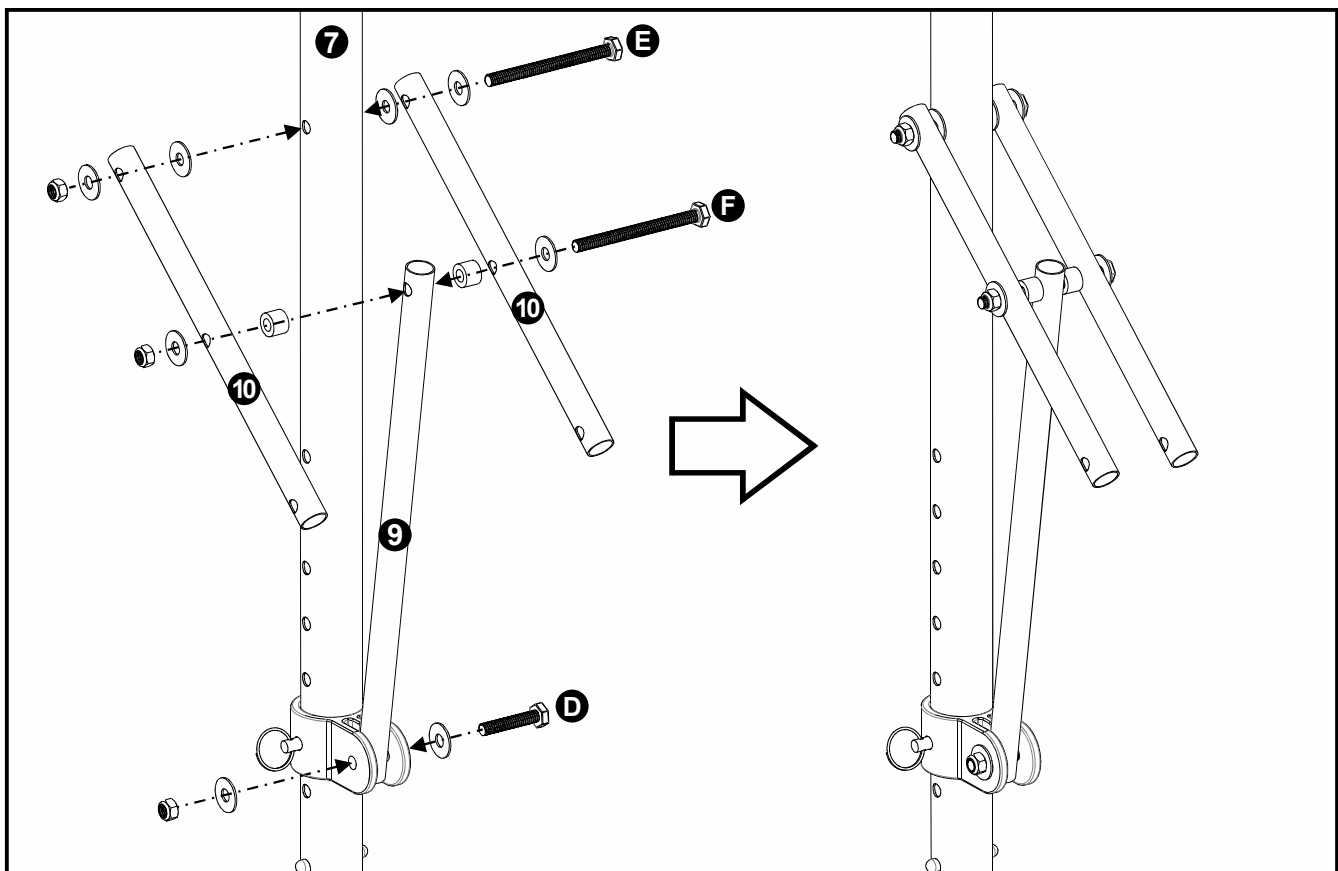

STEP C: ATTACH THE BACKBOARD

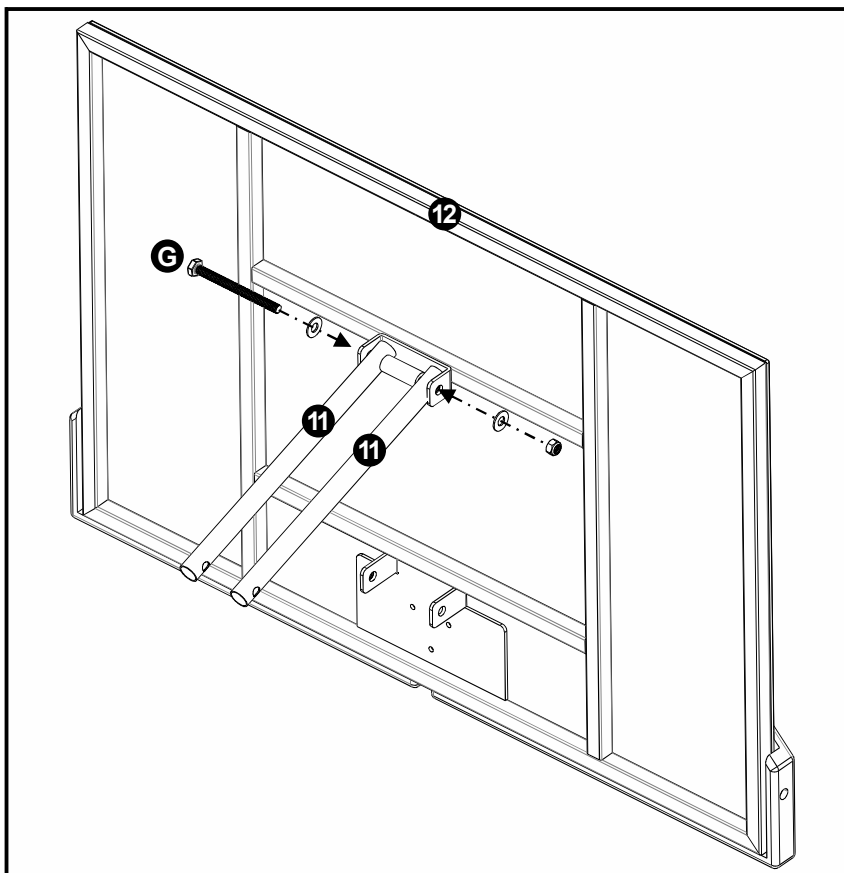

1. Lay the Backboard (12) face down on a flat and even surface.
2. Attach the x2 Upper Backboard Support Poles (11) to the upper bracket of the Backboard (12) using Hardware Set (G). Place the Long Spacer between the two poles as shown below:

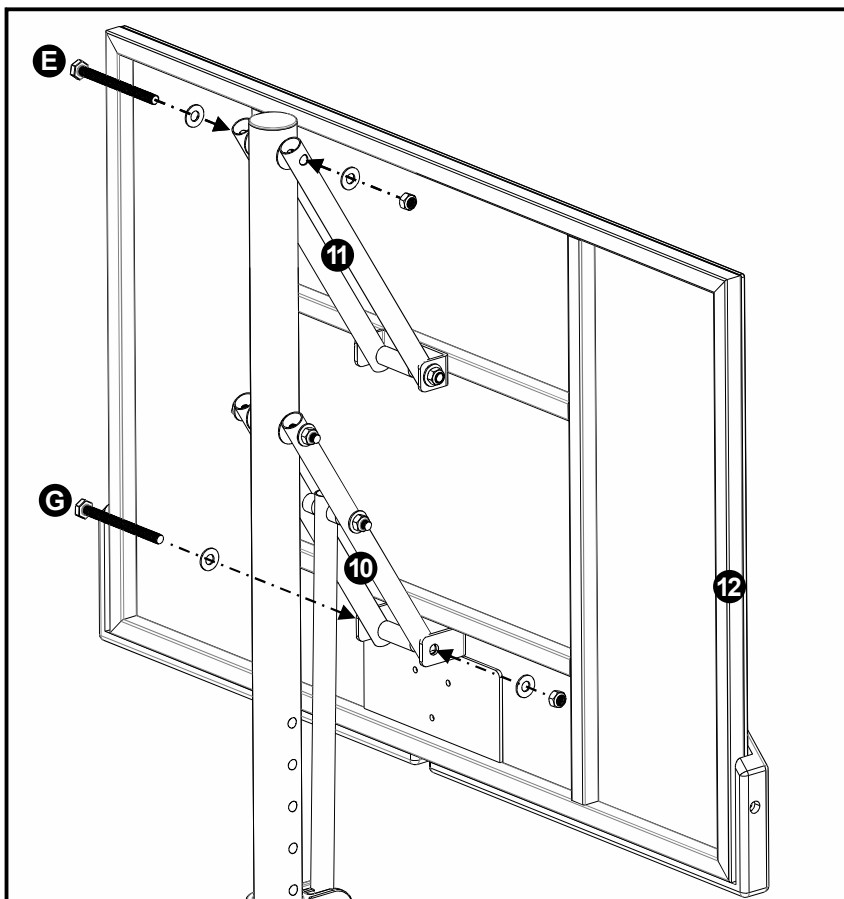
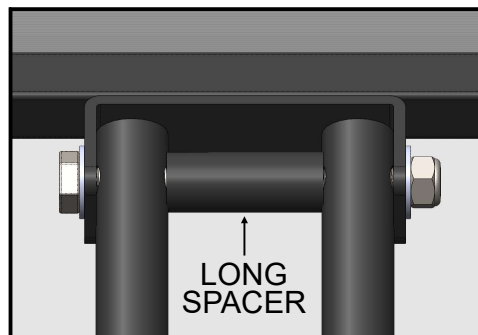

3. Carefully lift the Backboard into position and attach the x2 Upper Backboard Support Poles (11) to the Upper Post using Hardware Set (E).
IMPORTANT: Ensure that the Nylon Washers (plastic) are positioned between the Upper Post and Upper Backboard Support Poles on both sides.

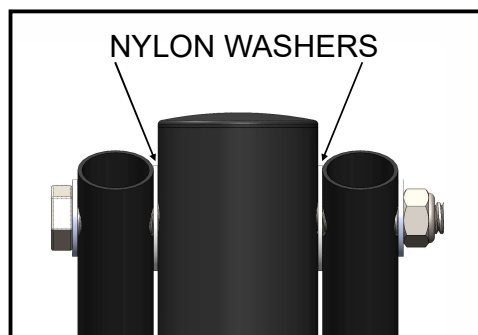

4. Next attach the x2 Lower Backboard Support Poles (10) to the lower bracket of the Backboard (12) using Hardware Set (G). Place the Long Spacer between the two poles as shown in 2. above.

STEP D: ASSEMBLE THE RIM

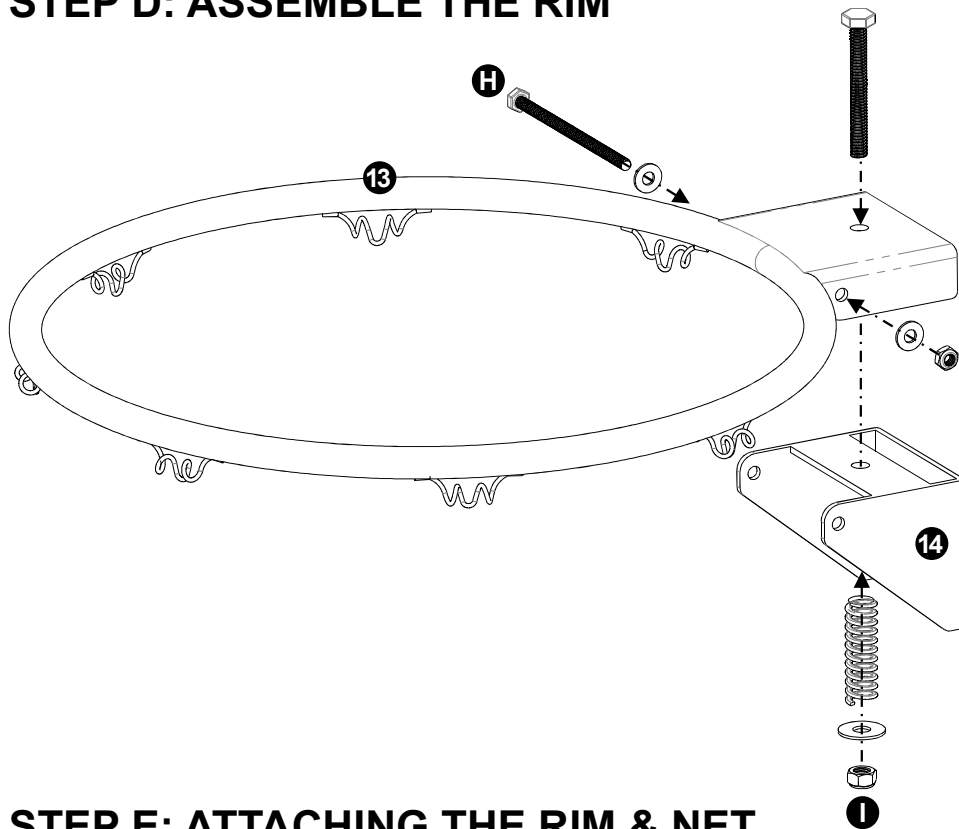

1. Connect the Rim (13) to the Rim Plate (14) using Hardware Set (H).
2. Attach the Spring using Hardware Set (I) by threading the Bolt through the Rim (13) and Rim Plate (14). Then slide the Spring over the bolt and secure with the Washer and M8 Nut.
3. **Adjusting Rim Spring Tension:**
 - Tightening the Nut increases the Rim's spring tension and will make the rim recoil quicker / be more responsive.
 - Loosening the Nut decreases the Rim's spring tension and will make the rim recoil slower / be less responsive.

STEP E: ATTACHING THE RIM & NET

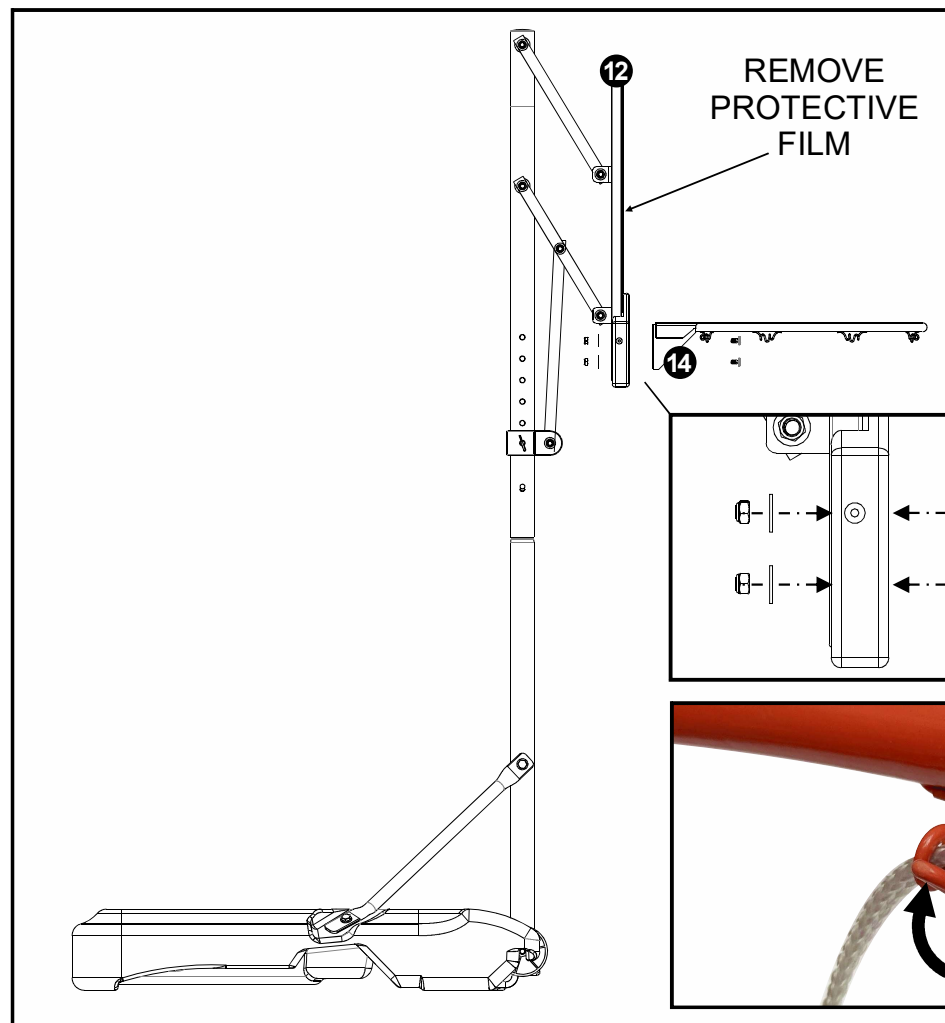

1. Remove the protective film from the front surface of the Backboard (12)
2. Attach the Rim Plate (14) to the Backboard (12) using Hardware Set (J).
3. Loop the long ends of the Net (16) over and around the rim hooks.
4. Finally: Check all Hardware is fully secured and tightened before play.

STEP F: ADDING THE MIDDLE POST

(NOTE: only complete this step if you intend to use the BMH System on its highest settings)

1. Press the Lower Post (4) spring buttons on both sides of the pole:

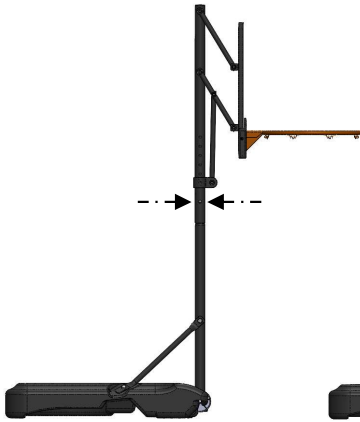

2. With both hands carefully lift the top section of the System off the Lower Post (4) and place on the ground:

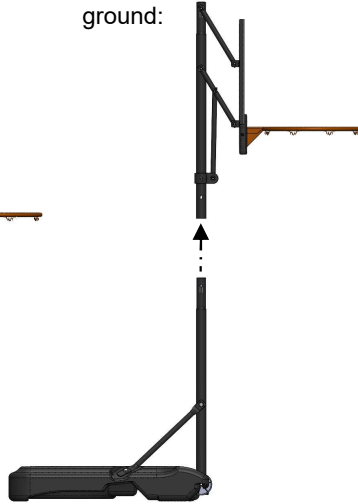

3. Connect the Middle Post (15) onto the Lower Post (4) and locate with the spring buttons:



4. Reconnect the top section of the System and locate with the spring buttons:

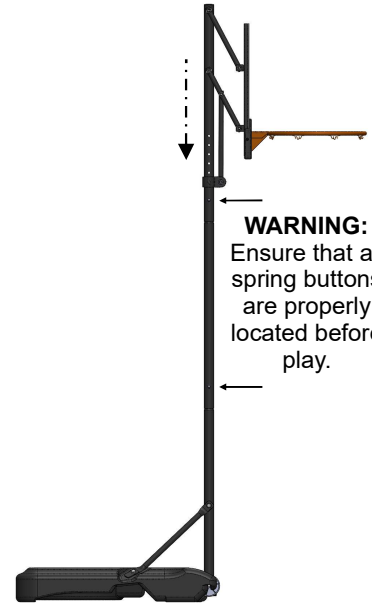

THANK YOU!

For choosing the QUICKPLAY BALLER MINI HOOP SYSTEM.
We hope you enjoy and get years of use out of this product.

If you have any issues, please do not return this product to the store. Instead contact us directly:

info@quickplaysport.com

We promise to resolve it or your money back.

At Quick Play Sport we think sport is all about taking part. We develop innovative products that help athletes and coaches at all levels of sport, perform to the best of their ability. If you have any queries or suggestions about how we can improve our products, we'd love to hear them.

Please feel free to get in touch... info@quickplaysport.com / +44 (0) 114 247 2327