



# ENERGY STAR® Program Requirements Product Specification for Central Air Conditioner and Heat Pump Equipment

## Eligibility Criteria Version 6.1

Following is the Version 6.1 product specification for ENERGY STAR certified central air conditioner and heat pump equipment. A product shall meet all of the identified criteria if it is to earn the ENERGY STAR.

**1) Definitions:** Below are the definitions of the relevant terms in this document.

- A. Central Air Conditioner (CAC) or Central Air Conditioning Heat Pump (HP)<sup>1</sup>: A product, other than a packaged terminal air conditioner or packaged terminal heat pump, which is powered by single phase electric current, air cooled, rated below 65,000 Btu per hour, not contained within the same cabinet as a furnace, the rated capacity of which is above 225,000 Btu per hour, and is a heat pump or a cooling unit only.

A central air conditioner or central air conditioning heat pump may consist of: A single-package unit; an outdoor unit and one or more indoor units; an indoor unit only; or an outdoor unit with no match. In the case of an indoor unit only or an outdoor unit with no match, the unit must be tested and rated as a system (combination of both an indoor and an outdoor unit).

- B. Single-package unit<sup>2</sup>: Any central air conditioner or heat pump that has all major assemblies enclosed in one cabinet.
- C. Split System<sup>2</sup>: Any air conditioner or heat pump that has at least two separate assemblies that are connected with refrigerant piping when installed. One of these assemblies includes an indoor coil that exchanges heat with the indoor air to provide heating or cooling, while one of the others includes an outdoor coil that exchanges heat with the outdoor air. Split systems may be either blower coil systems or coil-only systems.
- D. Multi-head mini-split system<sup>2</sup>: A split system that has one outdoor unit and that has two or more indoor units connected with a single refrigeration circuit. The indoor units operate in unison in response to a single indoor thermostat.
- E. Multiple-split (or multi-split) system<sup>2</sup>: A split system that has one outdoor unit and two or more coil-only indoor units and/or blower coil indoor units connected with a single refrigerant circuit. The indoor units operate independently and can condition multiple zones in response to at least two indoor thermostats or temperature sensors. The outdoor unit operates in response to independent operation of the indoor units based on control input of multiple indoor thermostats or temperature sensors, and/or based on refrigeration circuit sensor input (e.g., suction pressure).
- F. Ducted System<sup>2</sup>: An air conditioner or heat pump that is designed to be permanently installed equipment and delivers conditioned air to the indoor space through a duct(s). The air conditioner or heat pump may be either a split-system or a single-package unit. A ducted system may be any one of the following configurations:

---

<sup>1</sup> 10 CFR part 430, Subpart A, § 430.2 Definitions

<sup>2</sup> 10 CFR part 430, Subpart B, Appendix M1

- a. Ceiling-mount blower coil system<sup>2</sup>: A split system for which a) the outdoor unit has a certified cooling capacity less than or equal to 36,000 Btu/h; b) the indoor unit(s) is/are shipped with manufacturer-supplied installation instructions that specify to secure the indoor unit only to the ceiling, within a furred-down space, or above a dropped ceiling of the conditioned space, with return air directly to the bottom of the unit without ductwork, or through the furred-down space, or optional insulated return air plenum that is shipped with the indoor unit; c) the installed height of the indoor unit is no more than 12 inches (not including condensate drain lines) and the installed depth (in the direction of airflow) of the indoor unit is no more than 30 inches; and d) supply air is discharged horizontally.
- b. Low-static blower coil system<sup>2</sup>: A ducted multi-split or multi-head mini-split system for which all indoor units produce greater than 0.01 in. wc. and a maximum of 0.35 in. wc. external static pressure when operated at the cooling full-load air volume rate not exceeding 400 cfm per rated ton of cooling.
- c. Mid-static blower coil system<sup>2</sup>: A ducted multi-split or multi-head mini-split system for which all indoor units produce greater than 0.20 in. wc. and a maximum of 0.65 in. wc. when operated at the cooling full-load air volume rate not exceeding 400 cfm per rated ton of cooling.
- d. Mobile home blower coil system<sup>2</sup>: A split system that contains an outdoor unit and an indoor unit that meet the following criteria:
  - i. Both the indoor and outdoor unit are shipped with manufacturer-supplied installation instructions that specify installation only in a mobile home with the home and equipment complying with HUD Manufactured Home Construction Safety Standard 24 CFR part 3280;
  - ii. The indoor unit cannot exceed 0.40 in. wc. when operated at the cooling full-load air volume rate not exceeding 400 cfm per rated ton of cooling; and
  - iii. The indoor and outdoor unit each must bear a label in at least 1/4 inch font that reads “For installation only in HUD manufactured home per Construction Safety Standard 24 CFR part 3280.”
- e. Small-duct, high-velocity system<sup>2</sup>: A split system for which all indoor units are blower coil indoor units that produce at least 1.2 inches (of water column) of external static pressure when operated at the full-load air volume rate certified by the manufacturer of at least 220 scfm per rated ton of cooling.
- f. Conventional ducted system<sup>2</sup>: All ducted central air conditioners and heat pumps not otherwise listed above<sup>3</sup>, tested at a minimum external static pressure of 0.50 in. wc.
- G. Non-ducted Indoor Unit<sup>2</sup>: An indoor unit that is designed to be permanently installed, mounted on room walls and/or ceilings, and that directly heats or cools air within the conditioned space.
- H. Gas/Electric Package Unit: A single package unit with gas heating and electric air conditioning that is often installed on a slab or roof.
- I. Basic Model<sup>1</sup>: All units of a given type of covered product (or class thereof) manufactured by one manufacturer and which have the same primary energy source and, which have essentially

---

<sup>3</sup> One-to-one “mini-split” systems are categorized as either a non-ducted system (when testing without ductwork at 0 ESP) or as a conventional ducted system (when tested with ductwork at 0.50 in. wc). No categorization exists allowing mini-split systems to be tested at reduced external static pressures in a ducted configuration.

identical electrical, physical, or functional (or hydraulic) characteristics that affect energy consumption, energy efficiency, water consumption or water efficiency.

- J. Heating Seasonal Performance Factor 2 (HSPF2)<sup>4</sup>: HSPF2 is the total space heating required in region IV during the space heating season, expressed in Btu, divided by the total electrical energy consumed by the heat pump system during the same season, expressed in watt-hours. The represented value of HSPF determined in accordance with Appendix M1 is HSPF2, and the represented value in accordance with Appendix M is HSPF.
- K. Seasonal Energy Efficiency Ratio 2 (SEER2)<sup>4</sup>: SEER2 is the total heat removed from the conditioned space during the annual cooling season, expressed in Btu, divided by the total electrical energy consumed by the air conditioner or heat pump during the same season, expressed in watt-hours. The represented value determined in accordance with Appendix M1 is SEER2, and the represented value in accordance with Appendix M is SEER.
- L. Energy Efficiency Ratio 2 (EER2)<sup>4</sup>: EER2 is the ratio of the average rate of space cooling delivered to the average rate of electrical energy consumed by the air conditioner or heat pump. This ratio is expressed in Btu per Wh (Btu/Wh). The represented value determined in accordance with appendix M1 is EER2, and the represented value determined in accordance with Appendix M is EER.
- M. Coefficient of Performance (COP)<sup>2</sup>: COP means the ratio of the average rate of space heating delivered to the average rate of electrical energy consumed by the heat pump. These rate quantities must be determined from a single test or, if derived via interpolation, must be determined at a single set of operating conditions. COP is a dimensionless quantity.
- N. Percentage of Heating Capacity @ 5°F: The heating capacity of a given unit at 5°F, divided by the heating capacity at 47°F, expressed as a percentage.
- O. Independent Coil Manufacturer (ICM)<sup>2</sup>: A manufacturer that manufactures only the indoor unit (coil) in a Central Air Conditioner or Air-Source Heat Pump Split System.
- P. System Manufacturer (SM): A manufacturer that manufactures all the major assemblies in an Air-Source Unitary Heat Pump and/or Unitary Air-Conditioner.

## 2) Scope:

- A. Included Products: Single package, split system, and gas/electric package units that meet the definitions of a central air conditioner or heat pump as specified herein are eligible for ENERGY STAR certification, with the exception of products listed in Section 2.B. Units may be intended for installation into a duct system or may be ductless.
- B. Excluded Products: Three phase central air conditioners and heat pumps, and products rated at 65,000 Btu/h or above are covered in the [ENERGY STAR Light Commercial HVAC specification](#). Ground Source Heat Pumps are covered under the [ENERGY STAR Geothermal Heat Pump specification](#).

## 3) Certification Criteria:

- A. Climates: ENERGY STAR heat pumps that are optimized for peak heating and part-load cooling performance may use the Cold Climate certification mark if certified to meet the cold climate criteria. All other CACs and HPs may use the standard ENERGY STAR certification mark.

---

<sup>4</sup> Based on definition in 10 CFR part 430, Subpart B, Appendix M and M1

B. Energy Efficiency Requirements:

a. Certification Metric Criteria

- i. Version 6.0 allows an alternative for early certification using the Appendix M test method and associated metrics. This certification pathway will be available until January 1, 2022. After the specification effective date, all products certified early shall submit their relevant performance ratings per the Appendix M1 test method.

**Table 1: Energy-Efficiency Criteria for Certified Residential Central Air Conditioners**

Product Type	SEER2	EER2
CAC Split Systems	≥ 15.2	≥ 12.0
CAC Single Package Equipment <sup>1</sup>	≥ 15.2	≥ 11.5

<sup>1</sup>. Including gas/electric package central AC units.

**Table 2: Energy-Efficiency Criteria for Certified Residential Heat Pumps**

Product Type	SEER2	EER2	HSPF2
HP Split Systems	≥ 15.2	≥ 11.7	≥ 7.8
HP Single Package Equipment <sup>1</sup>	≥ 15.2	≥ 10.6	≥ 7.2

<sup>1</sup>. Including gas/electric package heat pumps, which are not eligible for the Cold Climate designation.

- ii. For purposes of ENERGY STAR certification, a Heat Pump model may be designated as Cold Climate as per the associated requirements in Table 3.

**Table 3: Energy-Efficiency Criteria for Certified Residential Cold Climate Heat Pumps**

Product Type	SEER2	HSPF2
HP Split Systems (Non-Ducted)	≥ 15.2	≥ 8.5
HP Split Systems (Ducted)	≥ 15.2	≥ 8.1
HP Single Package Equipment <sup>1</sup>	≥ 15.2	≥ 8.1

<sup>1</sup>. Excludes gas/electric package heat pumps, which are not eligible for the Cold Climate designation.

iii. Cold Climate Heat Pumps Low Ambient Performance: To earn the Cold Climate designation, heat pumps must demonstrate low ambient performance by meeting the following:

- COP at 5° F  $\geq$  1.75, measured in accordance with Appendix M1<sup>5</sup> H4<sub>2</sub> test.
- Percent of Heating Capacity at 5°F  $\geq$  70% of that at 47°F, with the 5° F capacity measured per Appendix M1 H4<sub>2</sub> test and the 47°F capacity measured as the nominal heating capacity per Appendix M1 (*i.e.*, from the Appendix M1 H1<sub>N</sub> test for units having a variable-speed compressor where the compressor speed shall be the maximum speed that the system controls would operate at 47°F, otherwise from the Appendix M1 H1<sub>2</sub> test)
- Perform a controls verification procedure (CVP) to confirm that the above performance metrics measured at the Appendix M1 low ambient test point at 5° F are achieved by the native controls operating as they would in a customer's home.

Alternative available prior to January 1, 2023:

- COP at 5° F  $\geq$  1.75, based on manufacturer provided application data.
- Percent of Heating Capacity at 5° F  $\geq$  70% of that at 47° F, with the heating capacity at 5°F based on manufacturer provided application data, and the heating capacity at 47° F measured per the Appendix M<sup>6</sup> H1<sub>2</sub> test.

C. Installation Capabilities: This section presents installation capabilities criteria for ENERGY STAR certified Central Air Conditioners and Heat Pumps. Compliance with Section 3.C criteria is optional. ENERGY STAR certified products that comply with all Section 3.C criteria will be identified on the ENERGY STAR website.

Centrally ducted CAC/HPs shall be capable of providing at least three of the following capabilities to aid in quality installation. Mini-splits and multi-splits shall have at least two of the capabilities. For purposes of this section, a thermostat or controller (for example, but not limited to devices such as smartphone or tablet with a manufacturer app to control the unit) can be considered part of the system. Items a, b, and c are understood to be measured at an appropriate fan speed and capacity.

- a. Refrigerant charge – System can self-verify that the refrigerant charge is within manufacturer recommended tolerances at a range of conditions including outdoor temperatures at least as low as 65°F or can estimate and report refrigerant charge level. An alert that only initiates when the charge is critically low does not satisfy this requirement.
- b. Airflow measurement or external static pressure – System shall have some capability to self-estimate and report airflow and/or confirm that it is within the OEM recommended settings, or to self-measure and display external static pressure and the fan speed setting. For split systems, this capability may be contingent on the recognized product being paired with a specific furnace or air handler. (Capability not applicable to ductless units.)
- c. Blower fan power draw – System shall have the capability to self-measure and report the watt draw of the blower fan. For split systems, this capability may be contingent on the recognized

---

<sup>5</sup> 10 CFR part 430, Subpart B, Appendix M1 – Section 3.6 Heating mode tests for Different Types of Heat Pumps, Including Heating-Only Heat Pumps

<sup>6</sup> 10 CFR part 430, Subpart B, Appendix M – Section 3.6 Heating Mode Tests for Different Types of Heat Pumps, Including Heating-Only Heat Pumps

product being paired with a specific furnace or air handler. (Capability not applicable to ductless units.)

- d. Test mode for manual measurements – The system provides an easily accessible test mode that locks the system into an appropriate fan speed and compressor capacity setting for testing refrigerant change, airflow/external static pressure, and blower fan power draw available in that installation.
  - e. Automatic system discovery – System is capable of automatically recognizing compatible communicating indoor/outdoor units, furnaces. Automatic discovery of humidifiers and dehumidifiers is encouraged.
  - f. Preprogrammed system tests – System shall automatically prompt the installer to run preconfigured system tests following the initial setup. These tests should verify, at a minimum, fan blower, cooling-mode, heat pump only heating, and auxiliary heating tests as applicable to the product and season of installation. The system shall store all faults recognized during these tests until the installer corrects the related issues.
- D. Multiple Assemblies: For split system central air conditioners and heat pumps, ENERGY STAR certification shall be determined by the rated performance of the particular combination of indoor and outdoor units as tested in accordance with the appropriate regional test procedure, regardless of the fact that the components may be used in other combinations
- E. Gas/Electric Package Units: To certify as ENERGY STAR, gas/electric package units shall meet the cooling portion of the single package specification requirements in Table 1 for CACs, or in Table 2 for HPs, above. Gas/electric packaged heat pumps may not achieve the Cold Climate heat pump label.
- F. ICM coil combinations: To certify as ENERGY STAR, ICM coil combinations shall meet the Central Air Conditioner and Heat Pump Split System specification requirements in Tables 1, 2 and 3 above and include a condensing (outdoor) unit listed in the ENERGY STAR program by a system manufacturer.
- G. The HSPF2 and SEER2 ratings for split systems shall be identical to the levels reported to DOE and appropriately reflected on the current Federal Trade Commission (FTC) Energy guide label. For packaged units, the HSPF2 and SEER2 ratings shall be identical to the levels reported on the Federal Trade Commission (FTC) Energy guide label and to those reported to DOE. For all units where EER2 (or EER) is reported to DOE, the EER2 reported to EPA shall be identical.
- H. Significant Digits and Rounding:
- a. All calculations shall be carried out with actual measured or observed values. Only the final result of a calculation shall be rounded. Unless otherwise directed below, calculated results shall be rounded to the nearest significant digit as expressed in the corresponding specification limit.
  - b. Unless otherwise specified, compliance with specification limit shall be evaluated using exact values without any benefit from rounding.
  - c. As specified in 10 CFR, 430.23(m)(3), SEER2, and HSPF2 shall be rounded off to the nearest 0.025 Btu/W.h. Similarly, EER2 should also be rounded off to the nearest 0.025 Btu/W.h.
  - d. As specified in 10 CFR, 430.23(m)(3), capacity shall be expressed in accordance with Table 4, below:

**Table 4: Rounding Requirements for Capacity**

Capacity Ratings, Btu/h	Multiples, Btu/h
< 20,000	50
≥ 20,000 and < 38,000	100
≥ 38,000 and < 65,000	250

**4) Connected Product Criteria:**

This section presents connected criteria for ENERGY STAR certified Central Air Conditioners and Heat Pumps. Compliance with Section 4 criteria is optional. ENERGY STAR certified products that comply with all Section 4 criteria will be identified on the ENERGY STAR website as having ‘Connected’ functionality.

**A. Definitions**

- a. **Connected CAC/HP System (CCS):** Includes the ENERGY STAR certified Central Air Conditioner or Heat Pump product, integrated or separate communications hardware, and additional hardware and software required to enable connected functionality, including controllers/thermostats. In the case of a CCS that implements Open ADR 2.0 with a virtual end node (VEN) in the cloud, that VEN is part of the CCS for purposes of this specification. For products implementing CTA-2045A, the module is not considered part of the CCS for purposes of this specification. A product implementing both using a communication module in a CTA-2045 port could be tested both ways and identified as implementing both standards for the purposes of the ENERGY STAR product finder.
- b. **Consumer Authorized Third Party:** Any entity for which the consumer has provided explicit permission to access the CCS connected functionality, in whole or in part, via a communication link.
- c. **Communication Link:** As shown in Figure 1, the mechanism for bi-directional data transfers between the connected CAC/HP system and one or more external applications, devices or systems.

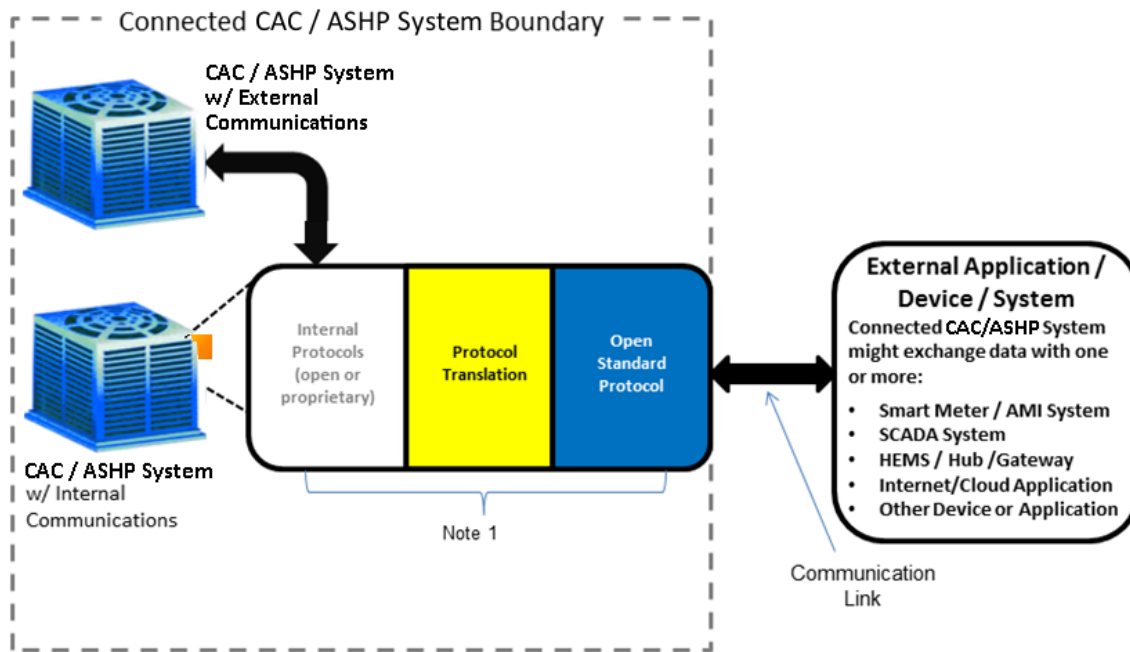

**Figure 1.** Connected CAC/HP System (CCS)

**Note 1:** Communication device(s), link(s) and/or processing that enables Open Standards-based communication between the CCS and external application / device / system(s). These elements, either individually or together, could be within the product/controller, and/or an external communication module, a hub/gateway, or in the Internet/cloud.

- d. Demand Response (DR)<sup>7</sup>: Changes in electric usage by demand-side resources from their normal consumption patterns in response to changes in the price of electricity over time, or to incentive payments designed to induce lower electricity use at times of high wholesale market prices or when system reliability is jeopardized.
- e. Demand Response Management System (DRMS): The system operated by a program administrator, such as the utility or third party, which dispatches signals with DR requests and/or price signals to the CCS products and receives messages from the CCS product.
- f. Interface Specification: A document or collection of documents that contains detailed technical information to facilitate access to relevant data and product capabilities over a communications interface.
- g. Load Management Entity: DRMS, home energy management system, and the like.

<sup>7</sup> Federal Energy Regulatory Commission, <https://www.ferc.gov/electric/industry-activity/demand-response/national-assessment-and-action-plan-demand-response>. This definition does not cover all aspects of how load flexibility is being used by utilities. For instance, it does not cover behavioral DR, dispatch to prevent spilling wind resources, or reducing peak demand for natural gas. EPA intends to address any and all of these use cases in our criteria in addition to the more traditional DR in the FERC definition.



- h. **Open Standards:** Communication with entities outside the CCS that use, for all communication layers, standards:
- included in the Smart Electric Power Alliance (SEPA) Catalog of Standards<sup>8</sup>, and/or
  - included in the NIST Smart Grid Framework Tables 4.1 and 4.2<sup>9</sup>, and/or
  - adopted by the American National Standards Institute (ANSI) or another well-established international standards organization such as the International Organization for Standardization (ISO), International Electrotechnical Commission (IEC), International Telecommunication Union (ITU), Institute of Electrical and Electronics Engineers (IEEE) or Internet Engineering Task Force (IETF).<sup>10</sup>
- i. **On-Premises:** Refers to a function that relies only on equipment present at the physical installed location of the ENERGY STAR certified device/equipment.
- j. **Consumer Override (of DR events):** Choosing to opt out of a scheduled and/or active DR event the product would otherwise respond to, without cancelling program enrollment.

B. **Communications**

- a. The CCS Communication Link, in Figure 1, shall use Open Standards for all communication layers to enable functions listed in Section 4D).
- b. An Interface Control Document (ICD), Application Programming Interface (API), or other documentation shall be made available to interested parties that, at minimum, allows access to the functions listed in Section 4D) and is recommended for Section 4C).

C. **Consumer Feedback**

a. **User Alerts**

The CCS shall be capable of providing at least two types of messages relevant to optimizing its energy consumption, communicating to residents either:

- i. On the product (if intended to be installed in conditioned space) or its consumer control interface, and/or
- ii. Transmitted to consumers and consumer authorized third parties via a communication link. This link can include open standards protocols used for Demand Response or could use a secondary communication link.

For example, messages relevant to energy consumption for CAC/HPs might address a fault condition, a reminder to replace a filter, heat pump refrigerant charge, or a report of energy consumption that is outside the product's normal range.

**Note:** Products meeting ENERGY STAR Most Efficient criteria for system status and messaging are compliant with this requirement.

---

<sup>8</sup> <https://sepapower.org/knowledge/catalog-of-standards/>

<sup>9</sup> <https://www.nist.gov/system/files/documents/smartgrid/NIST-SP-1108r3.pdf>

<sup>10</sup> <http://www.gridstandardsmap.com/>

**b. Energy Reporting**

The product shall be capable of transmitting measured or estimated instantaneous power draw in current conditions via a communication link to energy management systems and other consumer authorized devices, services, or applications. Provision of this information through the communication link and protocol used for demand response shall meet this requirement. *Example: A CCS uses CTA-2045A to comply with section 4D) and implements CommodityRead functionality.*

**D. Demand Response (DR)**

**a. DR Communications Protocols**

The CCS shall meet the communication and equipment performance standards for CTA-2045-A or OpenADR 2.0b, or both.

**b. Consumer Override**

The CCS shall provide an easily accessible means for consumers to override demand response events during the event or ahead of time for a scheduled event. When the event is overridden, the CCS shall return to its previous operating mode.

Temporary overrides shall be limited to a duration up to 72 hours without additional user input; after this time, the CCS will return to its previous operating mode.

**Note:** Long term (persistent) overrides are not restricted, as some users may opt to use this functionality. EPA recommends encouraging the use of temporary overrides to consumers when appropriate.

**c. DR Information and Messaging**

The CCS shall support the following upstream messaging from the device as supported by application layer protocol(s) and may support the additional (optional) messaging capabilities. Support for these messaging signals is implemented via the open standards protocol used in the product. Implementation details are described in Appendix A.

Required DR Messaging I/O:

<b>Messaging I/O Operation</b>	<b>Messaging Operation Description</b>
Verifying Connectivity	Ensures target CCS is connected to DRMS and prepared to accept DR signals.
System Capabilities	Requests basic CCS level information on target device, including equipment type response capability.
Operational State(s)	Requests information on CCS running state, DR conditions operating on product, opt in/out state, and current fault conditions. <b>Note:</b> Operational State data structure and layout may vary by application layer protocol, containing the following device state information:

Operational State Codes:

<b>Operational State Code</b>	<b>Operational State Definition</b>
Idle Normal	Indicates that no DR event is in effect and the CCS has no/insignificant energy consumption.
Running Normal	Indicates that no DR event is in effect and the CCS is running normal under local control.
Running Curtailed	Indicates that a curtailment type DR event is in effect and CCS is running in General Curtailment mode
Running Heightened	Indicates that a heightened-operation type of DR event is in effect and CCS is running in Critical Curtailment mode.
Idle Curtailed	Indicates that a curtailment type DR event is in effect and the CCS is in off mode.
CCS Error Condition	Indicates that the CCS is not operating or is in some way disabled (for example, no response to the grid).
Idle Heightened	Indicates that a heightened-operation type of DR event is in effect and the CCS is in off mode.
Idle Opted Out	Indicates that the HVAC system is presently opted out of any DR events and the system is in off mode.
Running, Opted Out	Indicates that the SGD is presently opted out of any DR events and the SGD is operating normal under local control.

**d. DR Requests and Responses**

The CCS shall also support the required DR operational modes listed below and may support additional open standard defined DR signals.

i. Required Operational Mode Functionality:

Operational Mode Function	Operational Mode Description
Maximum Indoor Temp. Rise	Specifies the maximum indoor temperature rise that the equipment must use when processing curtailment and/or price responsive modes.
General Curtailment	Directs equipment to reduce power consumption to a maximum of 70% of rated load power. Applicable to both staged and variable capacity equipment.
Critical Curtailment	Directs equipment to reduce power consumption to a maximum of 40% of rated load power. Staged equipment is not anticipated to respond to this message type; DRMS may substitute a General Curtailment message for this equipment type. Both staged and variable capacity equipment in heating mode shall not use resistance heating while indoor ambient temperature is equal to or above 62° F.
Off Mode	Directs equipment to turn to off mode, while maintaining compressor crankcase heater power and system controls power. Applicable to both staged and variable capacity equipment.
End Active Events	Notifies equipment that current or upcoming DR event(s) are cancelled.
Advanced Notification	Notifies equipment of an upcoming DR event. Equipment may perform preheating / precooling as appropriate. Note: Protocol dependent, may be attached to DR signals in some application layers.
Utility Peak Load Price Signal	Notifies equipment that a peak price period is in effect and contains relative pricing info on this event. Equipment manufacturer may provide user with the means to configure system to automatically respond to peak load price signals.
Customer Override	Notifies DRMS that a consumer has overridden a current / scheduled DR event.

ii. Operational Requirements:

Variable capacity equipment must ramp up/down changes in power over a minimum of 5 seconds, to decrease transients generated by operation.

E. Additional Information for Consumers

- a. If additional modules, devices, services, particular controllers/thermostats, and/or supporting infrastructure are required in order to activate the CCS's communications capabilities, installation instructions and a list of these requirements shall be prominently displayed in the product literature and cut sheets. These instructions shall provide specific information on what must be done to activate these capabilities (e.g. the brochure might include, "This product can participate in utility demand response programs if paired with model XD1124 thermostat, which has Wi-Fi capability and would also require Internet connectivity and a wireless router for this functionality.")

## 5) Test Requirements:

- A. One of the following sampling plans shall be used for purposes of testing for ENERGY STAR certification:
- a. A single unit is selected, obtained, and tested. The measured performance of this unit and of each subsequent unit manufactured must be equal to or better than the ENERGY STAR specification requirements. Results of the tested unit may be used to certify additional individual model variations within a Basic Model as long as the definition for Basic Model provided in Section 1, above, is met; or
  - b. Ratings are determined pursuant to the sampling requirements defined in 10 CFR Part 429, Subpart B § 429.16 either by selecting units for testing or by the application of an alternative rating method (ARM) as defined in 10 CFR Part 429.70. The certified rating must be equal to or better than the ENERGY STAR specification requirements. Results of the tested or simulated unit may be used to certify additional model variations within a Basic Model as long as the definition for provided above and in 10 CFR Part 430.2 is met. Further, all individual models within a Basic Model must have the same certified rating per DOE's regulations in Part 429 and this rating must be used for all manufacturer literature, the certified product list, and certification of compliance to DOE energy conservation standards.
- B. When testing central air conditioners and heat pumps, the following test method shall be used to determine ENERGY STAR certification:

**Table 5: Test Method for ENERGY STAR Certification**

ENERGY STAR Requirement	Required For	Test Method Reference*
SEER2, EER2, HSPF2	All CAC/HP	10 CFR part 430 Subpart B Appendix M1, including the optional H4 very low temperature condition
SEER, EER, HSPF		Alternative prior to January 1, 2022: 10 CFR part 430 Subpart B, Appendix M
COP @ 5° F, Percentage of Heating Capacity @ 5° F	Cold Climate HP Only	10 CFR part 430 Subpart B Appendix M1, including the optional H4 very low temperature condition
		Alternative prior to January 1, 2022: Manufacturer provided application data**
Controls Verification Procedure	Cold Climate HP Only	Controls Verification Procedure for Residential Heat Pump Low Ambient Performance
		Alternative prior to January 1, 2022: N/A
Installation Capabilities	CAC/HPs that have three or more capacities, or are continuously variable	Determined by examination of the product, its control system and its documentation
Connected Products: Demand Response	Optional Connected designation	Evaluation of Demand Response in CAC/HP (in development) or certification to AHRI 1380*** and examination of product documentation and interfaces

\* Note that cold climate heat pumps certified using Appendix M1 data shall also use Appendix M1 data for low ambient performance and shall perform a Controls Verification Procedure

\*\* Prior to 1/1/2022, products may certify COP @ 5° F and heating capacity @ 5° F with manufacturer provided application data. Percent Heating Capacity @ 5° F will be heating capacity

@ 5° F (based on manufacturer provided application data) divided by heating capacity @ 47° F (as measured by Appendix M).

\*\*\* Until a test method is established, products may certify as Connected through examination of the product, its control system and its documentation. Recognition as meeting ENERGY STAR connected criteria is optional.

**6) Effective Date:** This ENERGY STAR Central Air-Conditioners and Heat Pump Specification shall take effect on January 1, 2023. To certify for ENERGY STAR, a product model shall meet the ENERGY STAR specification in effect on the date of manufacture. The date of manufacture is specific to each unit and is the date (e.g., month and year) on which a unit is considered to be completely assembled.

**7) Future Specification Revisions:** EPA reserves the right to change the specification should technological and/or market changes affect its usefulness to consumers, industry, or the environment. In keeping with current policy, revisions to the specification are arrived at through industry discussions. In the event of a specification revision, please note that the ENERGY STAR certification is not automatically granted for the life of a product model.

In 2019 and 2020, EPA's ENERGY STAR Emerging Technologies program recognized highly efficient air to water heat pumps that have acceptable cold climate performance. As this technology gains a foothold in the US, EPA anticipates it will eventually make sense to include this type of product in the scope of the CAC/HP specification.

Appendix A: Demand Response Messaging:

Table 6: Normative DR Message Mapping

Category	Sub-type	Demand Response Messaging	Response Result	CTA (2045-A)	OpenADR (2.0b)
Basic Signals	Curtailment	<b>General Curtailment</b>	Reduce load (moderate)	Shed <sup>11</sup>	oadrDistributeEvent: SIMPLE level 1.. <sup>12</sup>
		<b>Emergency Curtailment</b>	Reduce load (major)	Critical Peak Event <sup>11</sup>	oadrDistributeEvent: SIMPLE level 2.. <sup>12</sup>
		<b>Off Mode</b>	Turn off (if possible)	Grid Emergency <sup>11</sup>	oadrDistributeEvent: SIMPLE level 3.. <sup>12</sup>
	Operational State	<b>Return to Normal Operation</b>	Return to defaults	End Shed / Run Normal <sup>11</sup>	oadrDistributeEvent: CANCELLED.. <sup>13</sup>
		<b>Advance Notice</b>	No requirement (flexible)	Pending Event Time / Type <sup>11</sup>	oadrDistributeEvent: NEAR / FAR / ACTIVE <sup>13</sup>
Advanced Signals	Device State (in event)	<b>Maximum Indoor Temp. Offset</b>	Adjust setpoint for use in curtailment / price response	Get / Set Temperature Offset <sup>14</sup>	oadrDistributeEvent: LOAD_CONTROL, x-loadControlSetpoint <sup>12</sup>
	Device Logic	<b>Utility Peak Load Price Signal</b>	Use / do not use energy when appropriate	Present Relative Price <sup>11</sup>	oadrDistributeEvent: ELECTRICITY_PRICE <sup>1</sup> <sub>2</sub>
Device Properties & Enrollment	Opt Out	<b>Consumer Override</b>	Skip response to event within opt out time window	Customer Override. Sent each time device is queried while opt out is active <sup>11</sup>	oadrCreateOpt, oadrCancelOpt. <sup>15</sup>
	Dev. Info	<b>Device Information</b>	Indicates product type	Info Request <sup>14</sup>	ei:eiTargetType (endDeviceAsset). <sup>16</sup>

<sup>11</sup> CTA-2045-A: Table 8-2

<sup>12</sup> OpenADR 2.0b, Section 8.2.2

<sup>13</sup> OpenADR 2.0b, Section 11.2

<sup>14</sup> CTA-2045-A: Table 9-2

<sup>15</sup> OpenADR 2.0b, Section 8.5

<sup>16</sup> OpenADR 2.0b, Annex A

	Status	<b>State Reporting Requirements</b>	Provide state information to requestor	Query / State Query Response <sup>14</sup>	EiReport. oadrPayloadResource- Status (see Table 7 and 8) <sup>13</sup>
	Hardware	<b>Hardware Requirements</b>	Design of product & comms.	AC or DC Form Factor physical interface	-
Device Energy	Energy	<b>Power (Instantaneous)</b>	Demand of product (W)	Get CommodityRead, code 0 <sup>17</sup>	oadrReport: energyReal <sup>13</sup>
		<b>Energy (Cumulative)</b>	Energy used by product (kWh)	Get CommodityRead, code 0 <sup>17</sup>	oadrReport: energyReal <sup>13</sup>

**Table 7: Operational State Codes**

Op State Code	Name
0	Idle Normal
1	Running Normal
2	Running Curtailed Grid
3	Running Heightened Grid
4	Idle Grid
5	Water Heater Error
6	Idle Heightened
11	Idle, Opted Out
12	Running, Opted Out

**Table 8: OpenADR 2.0b Operational State Reporting<sup>18</sup>**

<b>OpenADR 2.0b EiReport Service</b>			
REQ	Report Name	x-CTA2045_Status	
M1.1	Report Structure	Status	Interval
	rID	<b>OperationalState</b>	
	Report Type	Reading	
	Reading Type	Direct Read	
	Units	customUnit	
<b>ANSI/CTA-2045-A Message</b>			
Message		Operational State Query Response	
Element Mapped to rID		Opcode 2 of Basic 0x13	

<sup>17</sup> CTA-2045-A, Section 9.3.1

<sup>18</sup> Electric Power Research Institute, Communication Protocol Mapping Guide 1.0, OpenADR 2.0 to ANSI/CTA-2045-A, Table 2-3 Measurement and Reporting Mapping Requirements