

THE DIESEL DUDES



**DSP5 Switch
Install Reference**



Pin Numbers for your DSP5 Switch:

LML (2011-2016 Duramax)

Yellow Wire = Gray Plug, pin 11 || **Black Wire** = Gray Plug, pin 35

LMM 07-2010 trucks, please view the instructions included with the switch on what pins to use for installation.

Your Switch has a nut and two washers. The bottom smooth washer must remain on the bottom with the tab located in hole number five. If it falls out, turn the switch fully counterclockwise and place the washer back with the pin in hole five and make sure the switch moves exactly four clicks clockwise. If not, turn the switch back fully counterclockwise, move the pin and try again.

LML Switch Pin Install Locations

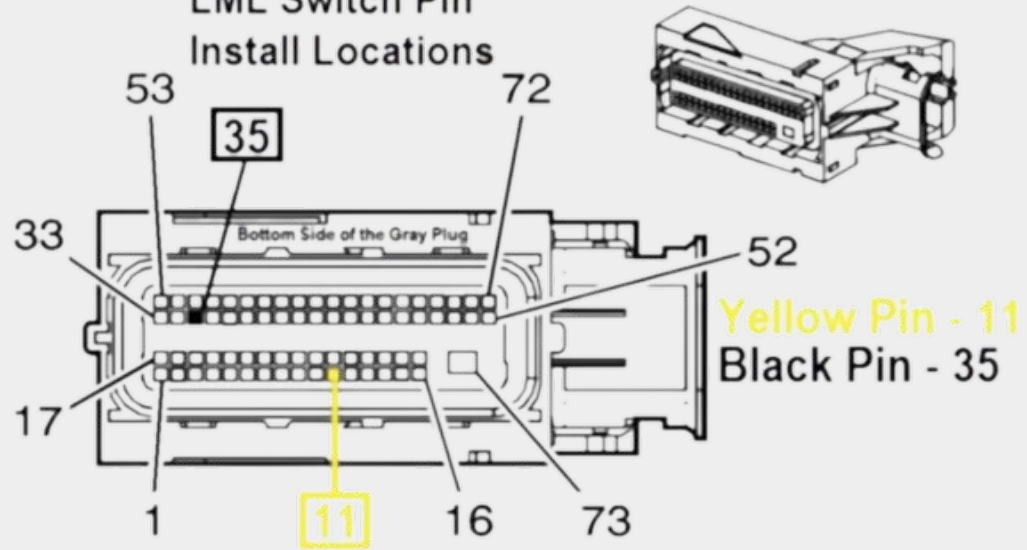

How to find Pin Locations - Reference Guide

1 - This video shows exactly where the switch should be connected. In the video, they use different connection ports (DO NOT USE THESE) please ensure to make the connections as illustrated in the previous page. This video is designed to help you find were the connections are.

<https://www.youtube.com/watch?v=uAFENQxDaEo&t=239s>

2 - This website shows you the pin locations on the board, the pin outs will be different follow the instructions on the guide as mentioned above.

<http://www.fishtuning.com/DSP5Install>

Still Running into issues?

Contact our support team via the following form:

<https://form.jotform.com/223478868814068>

Or

email support@thedieseldudes.com

Our Operating hours

10:30AM-6:30PM (EST)

