



# Daybed with trundle

INSTRUCTIONS MANUAL



**PRECAUTION:** ALWAYS READ AND FOLLOW INSTRUCTIONS BEFORE USE. ALWAYS USE THE UNIT ACCORDING TO THE MANUFACTURERS GUIDELINES. ONLY USE THE UNIT IN A MANNER AS INTENDED BY MANUFACTURER.

# Welcome to the family!

THANK YOU FOR PURCHASING OUR DAY BED TRUNDLE  
AND TRUSTING MILLIARD WITH PROVIDING  
YOURSELF AND YOUR LOVED ONES THE UTMOST  
COMFORT AND SUPPORT IN YOUR HOME.  
AS A FAMILY BRAND THAT STARTED BACK IN 2009 WE'VE  
DEDICATED OURSELVES TO CAREFULLY CRAFTING LINES  
OF PRODUCTS USED TO ELEVATE YOUR HOME. QUALITY  
AND FAIR PRICING IS OUR PROMISE TO YOU. YOU CAN  
TRUST THAT IF IT'S NOT GOOD ENOUGH FOR OUR HOME,  
IT'S NOT GOOD ENOUGH FOR YOURS.

**⚠️WARNING:** THIS PRODUCT IS TO BE ASSEMBLED BY AN ADULT. IN ITS UNASSEMBLED STATE THIS PRODUCT CONTAINS POTENTIALLY HAZARDOUS SHARP POINTS, SHARP EDGES, AND SMALL PARTS. KEEP OUT OF REACH OF CHILDREN.

DID YOUR UNIT COME WITH ANY DAMAGED OR MISSING PARTS?

# We're here to help.

OUR TEAM OF DEDICATED CUSTOMER CARE PROFESSIONALS ARE READY TO HELP YOU WITH ANY QUESTIONS OR CONCERNS YOU MAY HAVE.

FOR IMMEDIATE ATTENTION, CALL MONDAY-THURSDAY 9:00AM-5:00PM & FRIDAY 9:00AM-1:00PM.

OR YOU CAN LEAVE US A VOICE MESSAGE OR EMAIL, AND WE GUARANTEE YOU WILL HEAR BACK FROM US WITHIN ONE BUSINESS DAY.

PHONE: 866-686-4891

EMAIL: [INFO@MILLIARDBRANDS.COM](mailto:INFO@MILLIARDBRANDS.COM)



**MAINTENANCE:**

TO KEEP THE UNIT CLEAN, PERIODICALLY DUST AND WIPE IT WITH A DAMP CLOTH. FOR MORE EXTENSIVE CLEANING, USE A MILD CLEANSER AND A SOFT CLOTH.

# Bed Parts

1

HEADBOARD X2

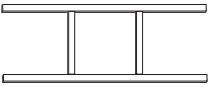

2

BED LEG X4



3

BED FRAME X2

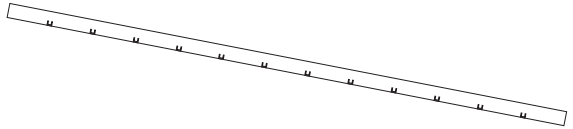

4

BED SLAT X24



5

TRUNDLE FRAME X2



6

TRUNDLE LEG SUPPORT X2



7

TRUNDLE END SLAT X2



# Hardware Parts

A

LONG BOLTS X16

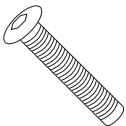

B

MEDIUM BOLTS X4



C

SMALL BOLTS X4



D

ALLEN KEY



E

RATCHET

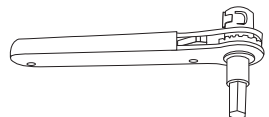

# Daybed Instructions

## STEP 1

ATTACH THE BED LEGS (2) TO THE HEADBOARDS (1) USING LONG BOLTS (A).

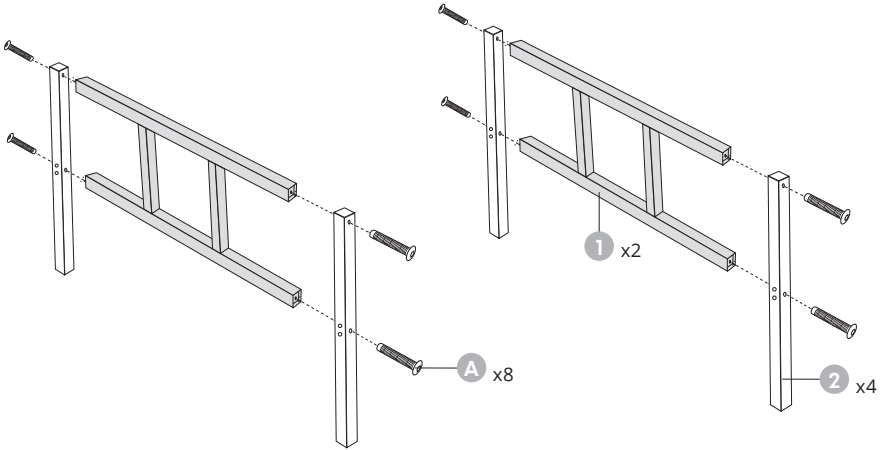

## STEP 2

SECURE THE BED FRAMES (3) TO THE BED LEGS (2) USING LONG BOLTS (A).

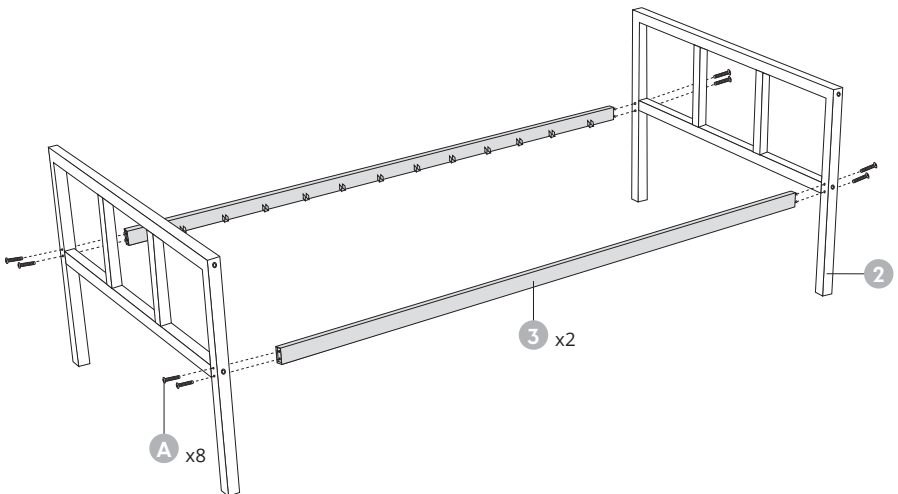

### STEP 3

INSERT THE BED SLATS (4) INTO THE BED FRAMES (3).

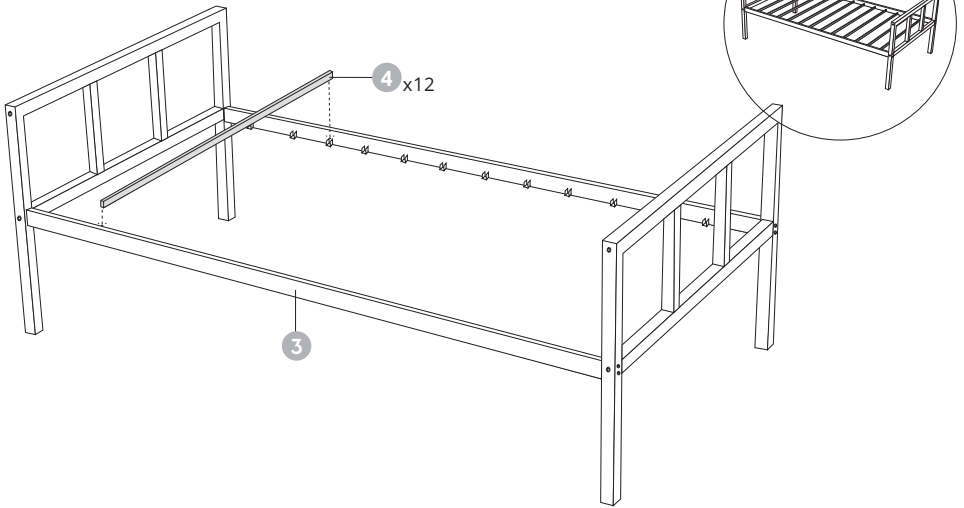

## Trundle Bed Instructions

### STEP 4

NOW, LET'S ATTACH THE TRUNDLE BOTTOM LEG (6) TO THE LEGS (5) ON THE TRUNDLE FRAMES USING SMALL BOLTS (C) .

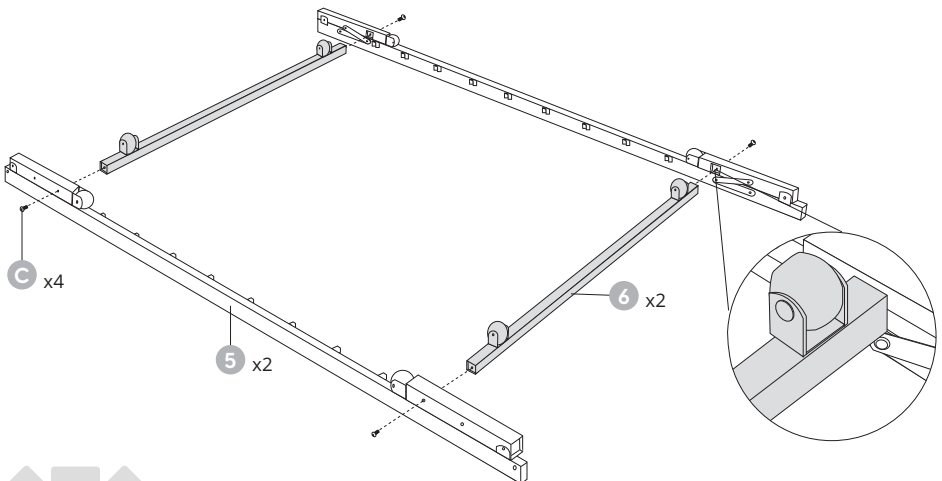

## STEP 5

OPEN THE LEGS UNTIL FULLY EXTENDED.

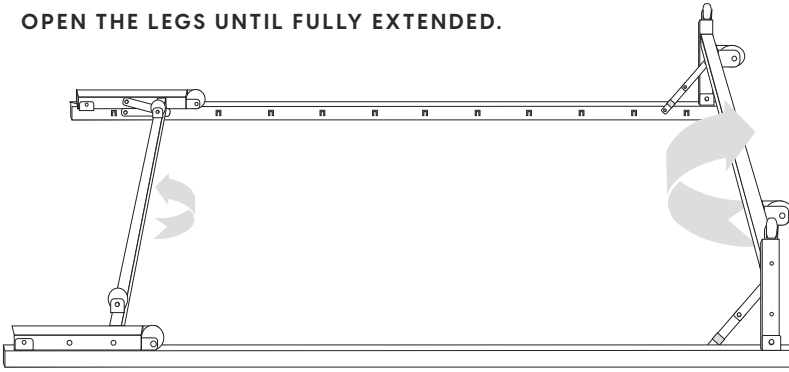

USING TWO PEOPLE, CAREFULLY STAND THE TRUNDLE ON ITS FEET.

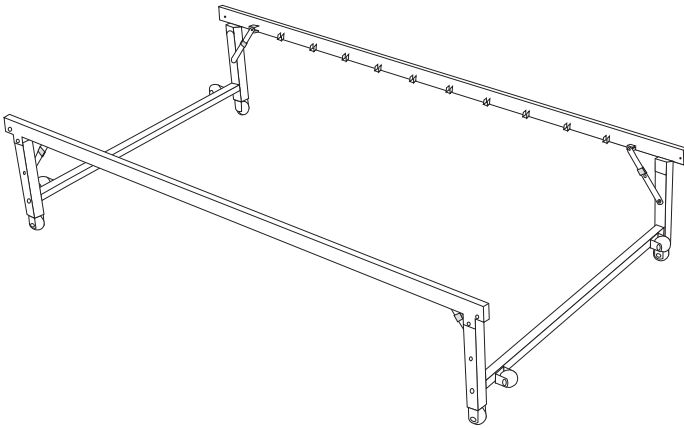

SECURE THE LEGS BY MOVING THE SECURITY CAPS DOWN.

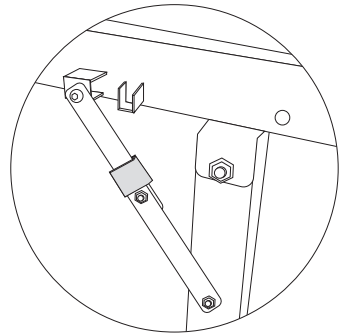
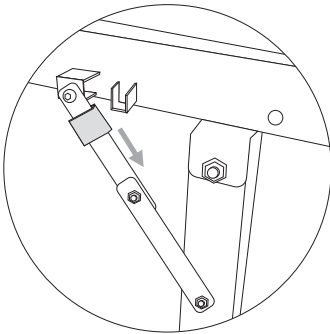

**⚠WARNING: FALL HAZARD.** Always place security caps in place around leg hinge before use. Failure to do so may lead to serious injury.

---

## STEP 6

ATTACH THE TRUNDLE SLAT (7) TO THE TRUNDLE FRAME (5) USING MEDIUM BOLTS (B).

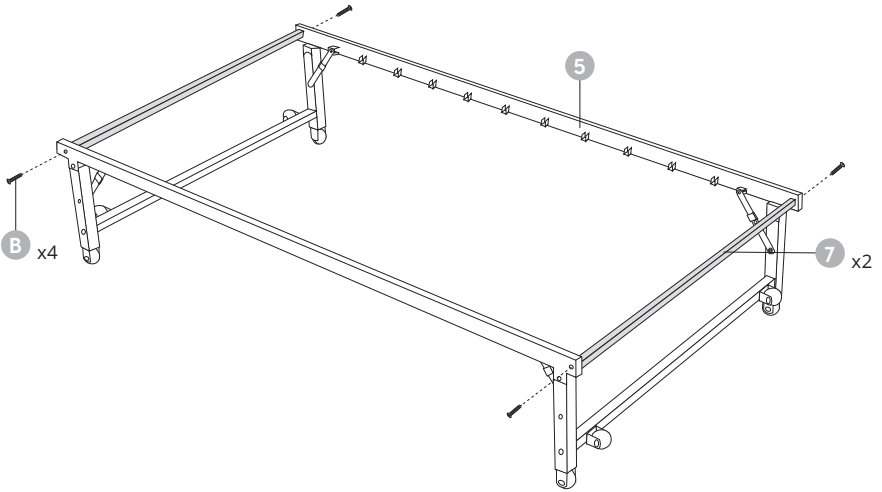

---

## STEP 7

INSERT THE BED SLATS (4) INTO THE TRUNDLE FRAME (5).

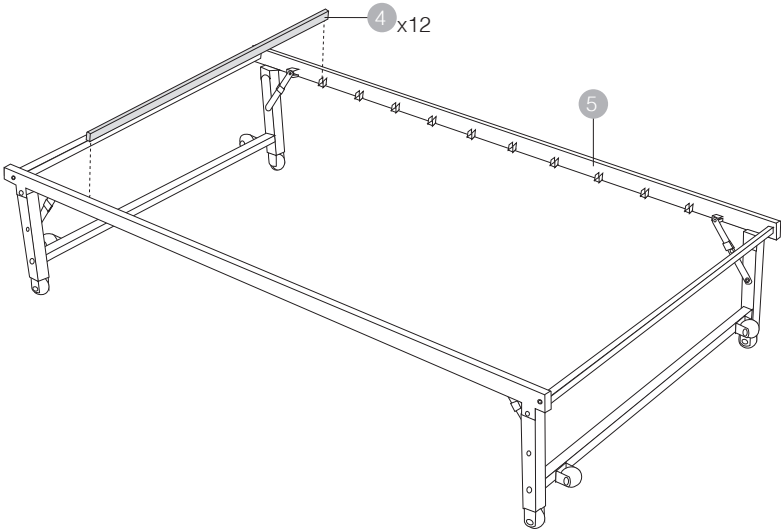

CONGRATULATIONS, YOU JUST FINISHED ASSEMBLY!





**⚠ WARNING: PINCH HAZARD.** Keep Children Away from Bed  
When folding bed

# Folding Instructions

**BEGINNING WITH THE FOOT END OF THE BED, MOVE UP THE SECURITY CAPS ON BOTH SIDES OF THE LEG STRUCTURE AT ONCE.**

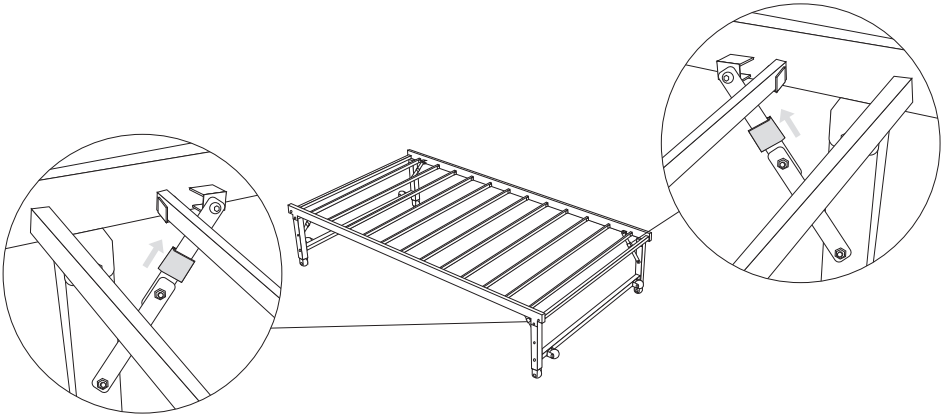

**HOLDING UP THE SECURITY CAPS AND MAKING SURE THAT YOUR FINGERS ARE CLEAR OF THE SUPPORT LEGS, SLOWLY PUSH THE HINGE FORWARD ON BOTH SIDES OF THE LEG STRUCTURE AT ONCE. IF YOU NEED HELP, REQUEST ASSISTANCE FROM ANOTHER ADULT.**

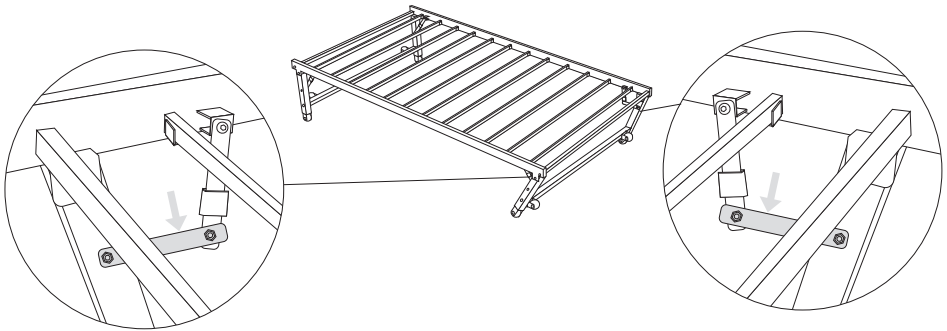

**BE SURE TO SUPPORT THE TRUNDLE END SLAT SO THE TRUNDLE IS LOWERED SLOWLY.**

**NOTE: THE HINGES ARE STIFF TO ENSURE THAT THE BED RAISES AND LOWERS SLOWLY AND SAFELY.**



**CAREFULLY REPEAT THESE INSTRUCTION ON THE OPPOSITE SIDE OF THE BED.**

**ONCE BOTH LEGS ARE SECURELY FOLDED, ROLL THE TRUNDLE UNDERNEATH THE DAYBED.**

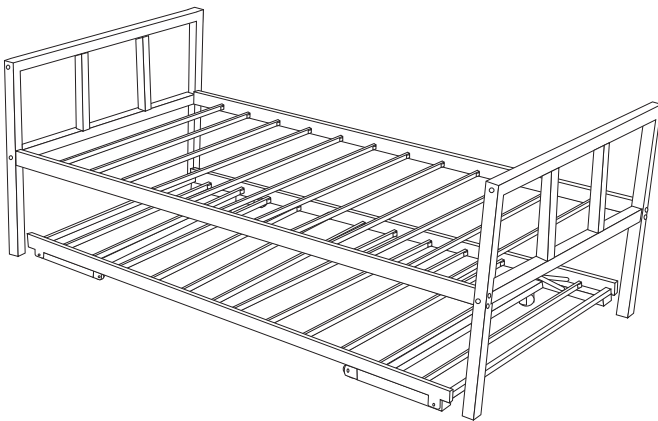
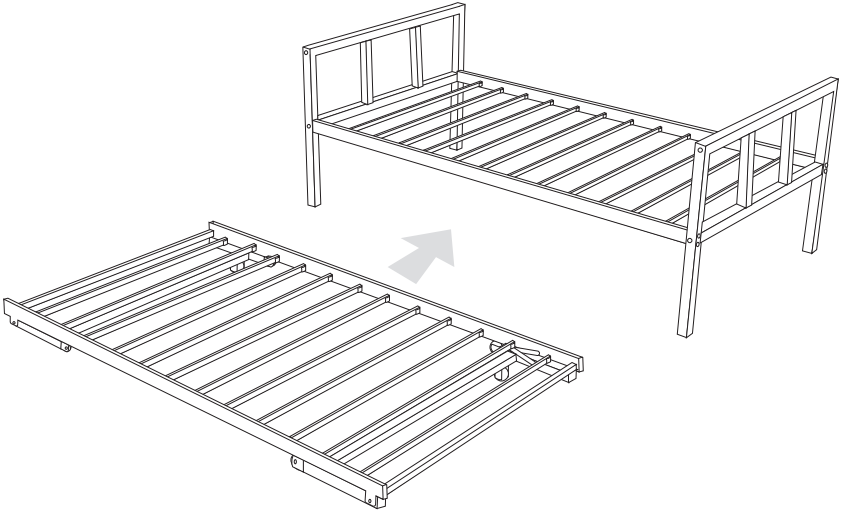

# Opening Instructions

**TO BEGIN, ROLL OUT THE TRUNDLE FROM UNDER THE DAYBED.**

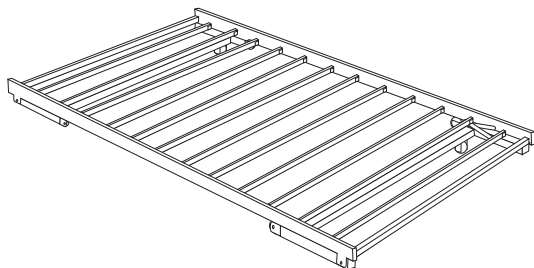

**EXTEND THE LEG STRUCTURE FROM ONE OF THE SIDES.**

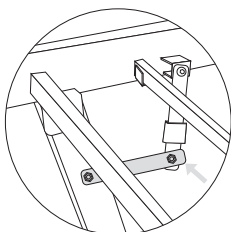
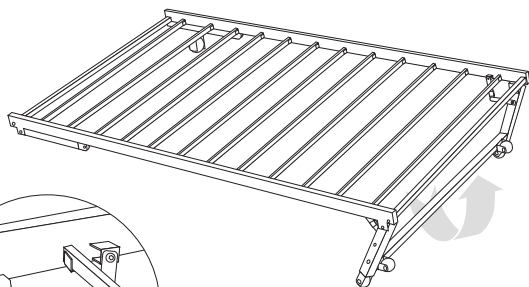

**STRAIGHTEN THE HINGE AND SECURE THE LEGS STRUCTURE BY MOVING THE SECURITY CAPS DOWN.**

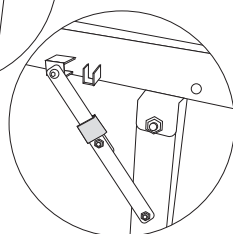
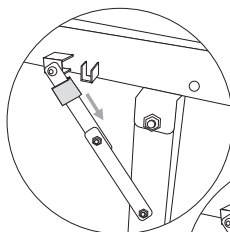
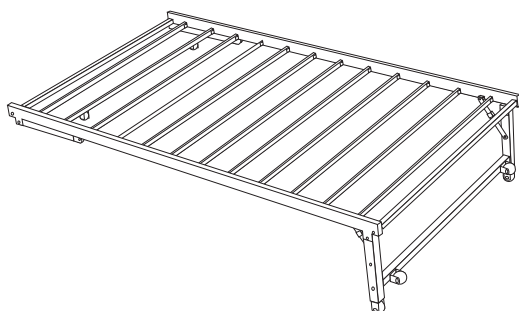

**REPEAT TO OPEN THE OPPOSITE END OF THE BED.**



# Thank you again!

YOU'VE OFFICIALLY COMPLETED ALL ASSEMBLING,  
OPENING AND CLOSING INSTRUCTIONS. THANK  
YOU AGAIN FOR YOUR PURCHASE OF OUR DAY BED  
TRUNDLE SET. WE HOPE YOU'RE LOVING IT!



PHONE: 866-686-4891 EMAIL: [INFO@MILLIARDBRANDS.COM](mailto:INFO@MILLIARDBRANDS.COM)