

Video Coming Soon!

 /fotodioxinc

5in1 Reflector

Instruction Manual

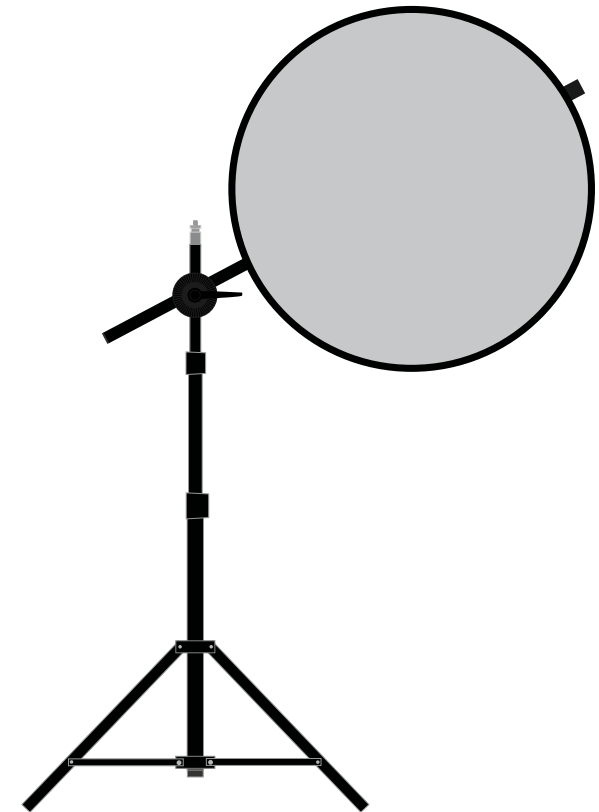

www.fotodiox.com

CONTACT Us:

For Information Regarding this
and more of our products,
please contact us:

E-mail: info@fotodiox.com
Phone: 847.201.4623
www.fotodiox.com

3805 Hawthorne Ct.
Waukegan IL, 60087

We're also on:



5in1 REFLECTOR

Specs and Features

Product Overview

FOTODIOX PREMIUM GRADE 5in1 REFLECTOR provides the ultimate in photo solutions. Use as a fill reflector with a soft cold silver, neutral white or warm tone gold. Can be used as a plain diffuser or use the black to block unwanted light. The Fotodiox Premium Grade 5in1 reflector disc is made of premium grade, quality reflective and diffusive materials guaranteed to flatten out when opened. A slip-cover with four colors are enclosed with the diffusive disc: soft gold, black, soft silver, and soft white. Disc collapses down to about 1/3 of its original size for easy storage and transportation. This kit includes the Fotodiox 6ft or 8ft Stand and Fotodiox Telescoping Reflector Holding Arm.

Product Features

- Pro-grade material, heavy duty construction
- Kit with 6ft or 8ft stand and telescoping boom holder
- Collapsible for portability
- 5 applications in one for all photo occasions
- 24 Month manufacture warranty

CONTENTS

5 in 1 Reflector Kit Includes

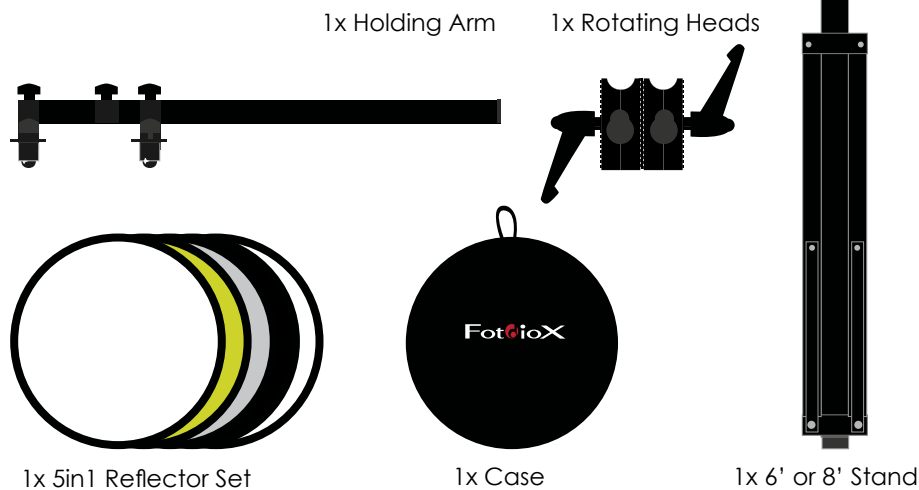

ASSEMBLING THE REFLECTOR

The Stand

1. Unfold the stand by loosening the locking nob and slightly pulling the legs out

Continue by pushing the leg lock piece down until legs are unfolded and steady

NOTE: tighten nob to lock legs

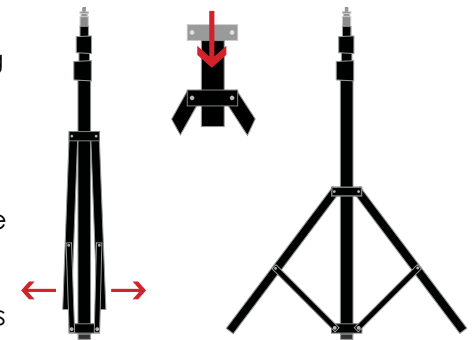

ASSEMBLING THE REFLECTOR

Understanding the Rotating Heads

The Rotating Heads have four different size holes to fit all of our holding arms and stands including our boomstands

Each of the heads split an extra inch apart to clamp on to thicker stands

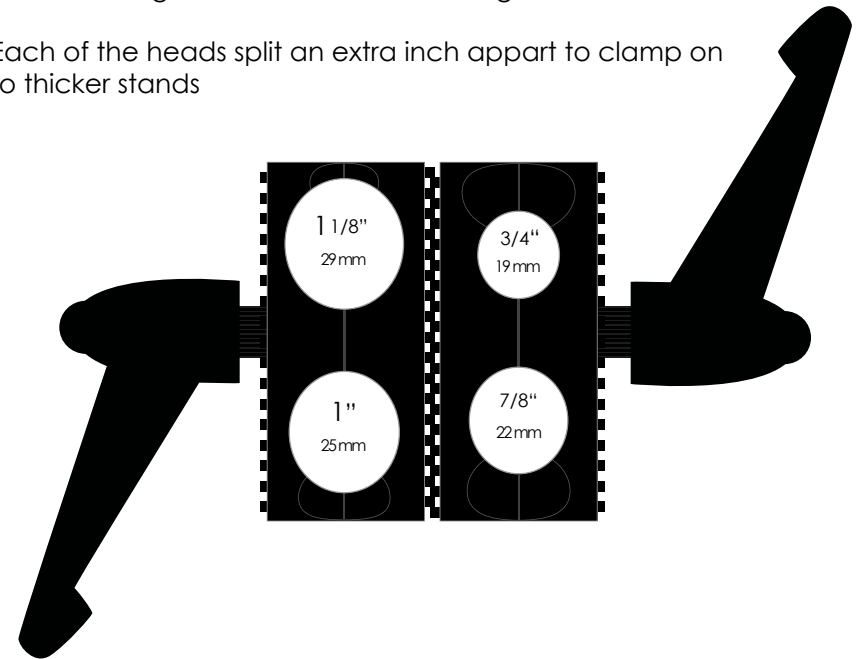

NOTE: The rotating heads both have all 4 of the different size holes

ASSEMBLING THE REFLECTOR

The Rotating Heads

Instructions for the 6ft stand

2 To mount the rotating heads to the **6ft** stand, locate the 3/4" hole on one of the heads

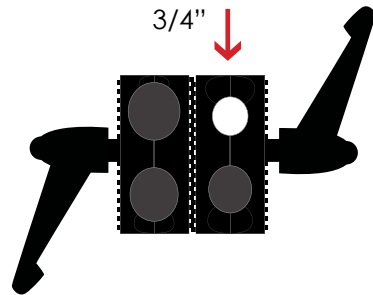

3 Without losing sight of the 3/4" hole, detach half of the head by unscrewing the handle and clamping it to the second extension pole

NOTE: Careful not to lose the spring or washers

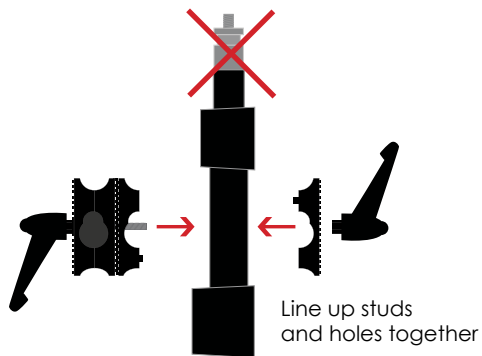

NOTE: The **6ft** stand's first extension pole is too thin to hold the rotating head

Instructions for the 8ft stand

2 To mount the rotating heads to the **8ft** stand, locate the 1" hole on one of the heads

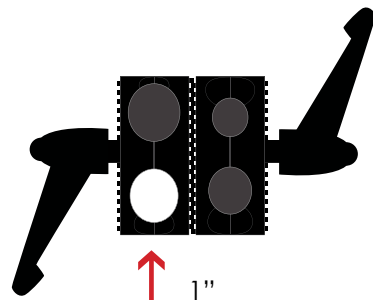

ASSEMBLING THE REFLECTOR

The Rotating Heads

3 Loosen the head by giving the handle a few of turns; Slide and clamp the 1" hole to the first extension pole

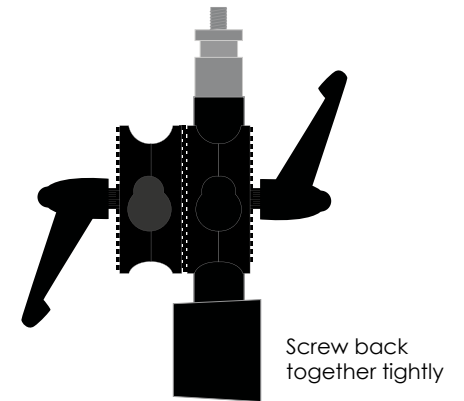
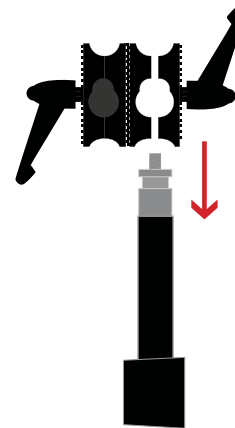

ASSEMBLING THE REFLECTOR

The Arm

1 To attach the arm to the second head locate the 7/8" hole and loosen the head by giving the handle a few turns

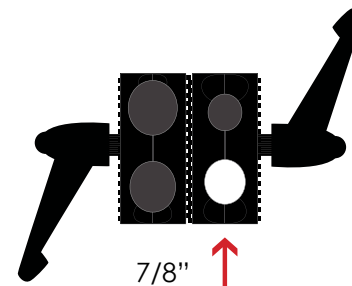

2 Slide arm in and tighten the head to lock arm in position

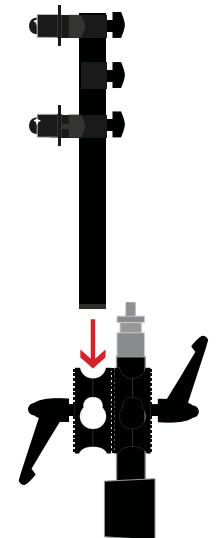

ASSEMBLING THE REFLECTOR

The Reflector

- 1 Extend the arm to the width of the reflector disk by loosening the handles

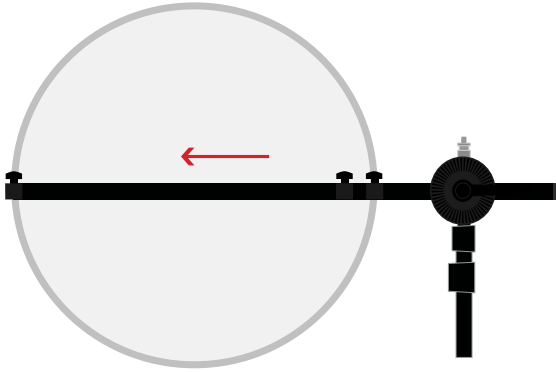

- 2 Using the clips from the holding arm, clip the disc's metal frame onto the arm

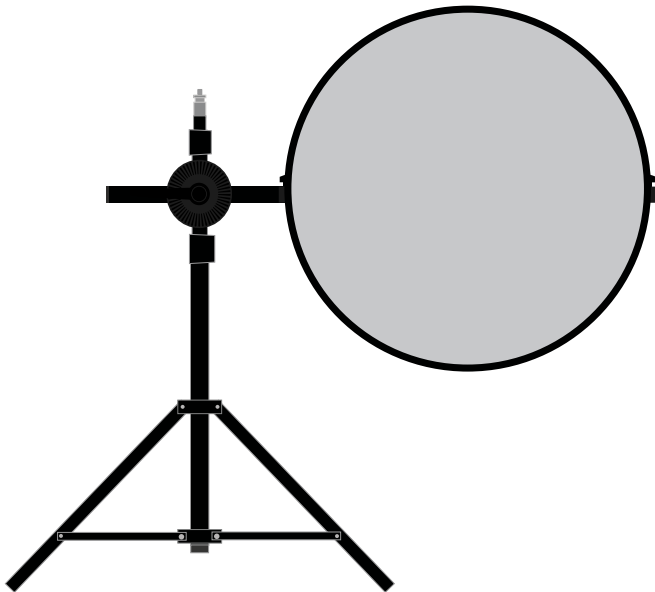

ASSEMBLING THE REFLECTOR

The Rotating Heads

- 1 To adjust the angle of the reflector holding arm, loosen the rotating heads enough to unlock the teeth

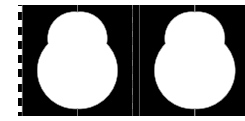

Teeth Locked

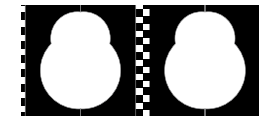

Teeth Unlocked

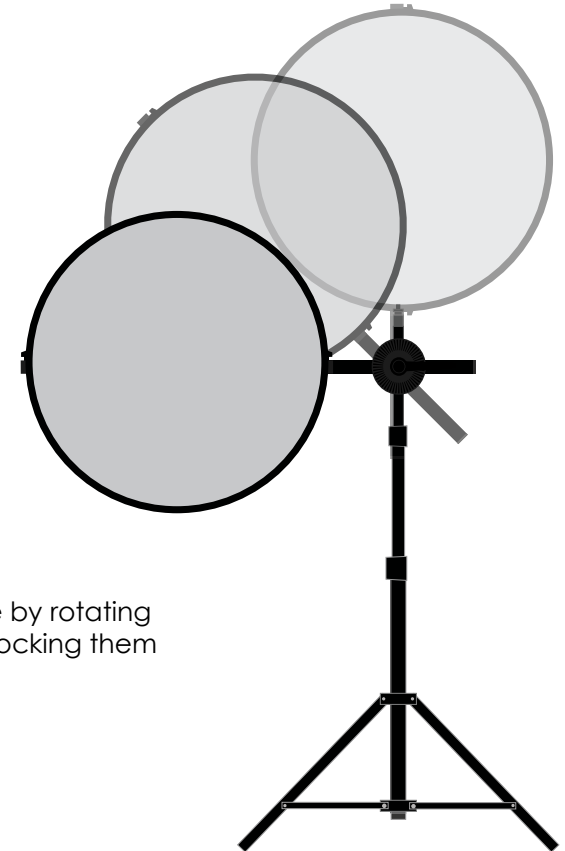

- 2 Adjust the angle by rotating the heads and locking them in position