







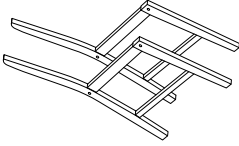

ASSEMBLY INSTRUCTIONS

MODEL : DC1040

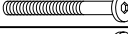
ITEM	PART NAME	QTY
1	Seat Board 	1 PC
2	Back Rest 	1 PC
3	Leg R&L 	2 PCS
4	Apron 	2 PCS

ITEM	HARDWARE LIST	DESCRIPTION	QTY
A	Allen Key M4 Long		1 PC
B	JCBB M6 x 55		4 PCS
C	JCBB M6 x 30		4 PCS
D	Wood Dowel M8 x 30mm		8 PCS
E	Barrel Nut		4 PCS
F	Wood Button 14.5mm		8 PCS
G	Pan Head M4 x 32mm		6 PCS

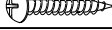
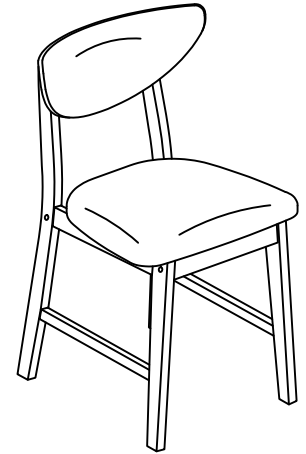

STEP 1

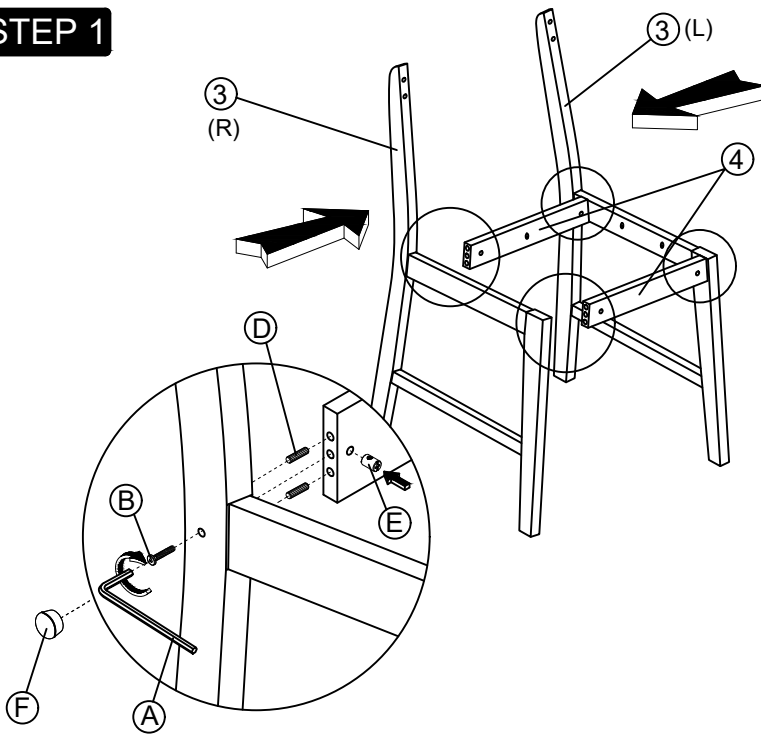

STEP 2

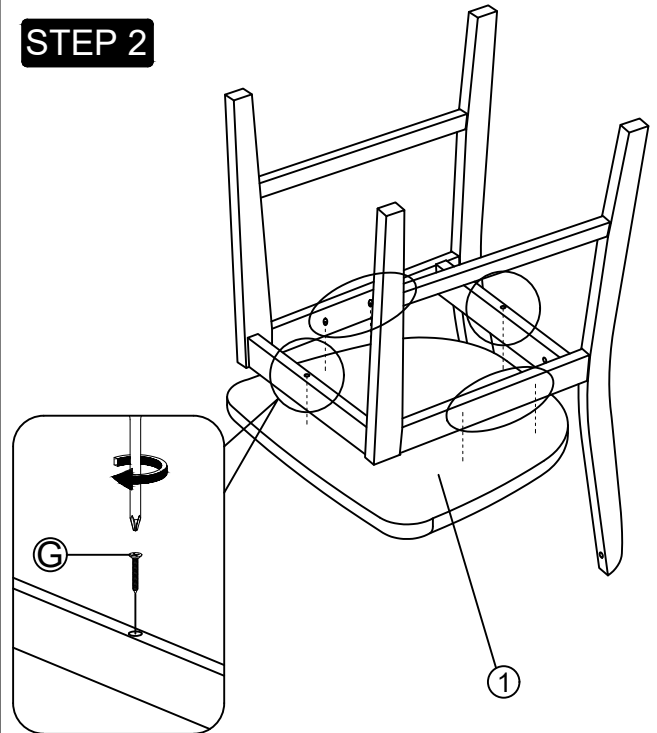

STEP 3

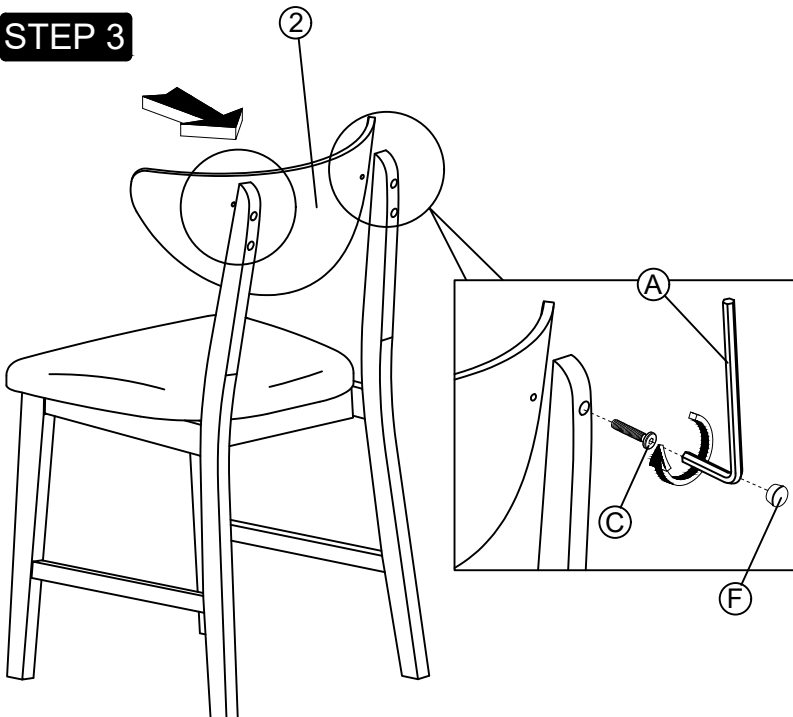

STEP 4

