

RIO CHANGE TABLE

ASSEMBLY INSTRUCTION

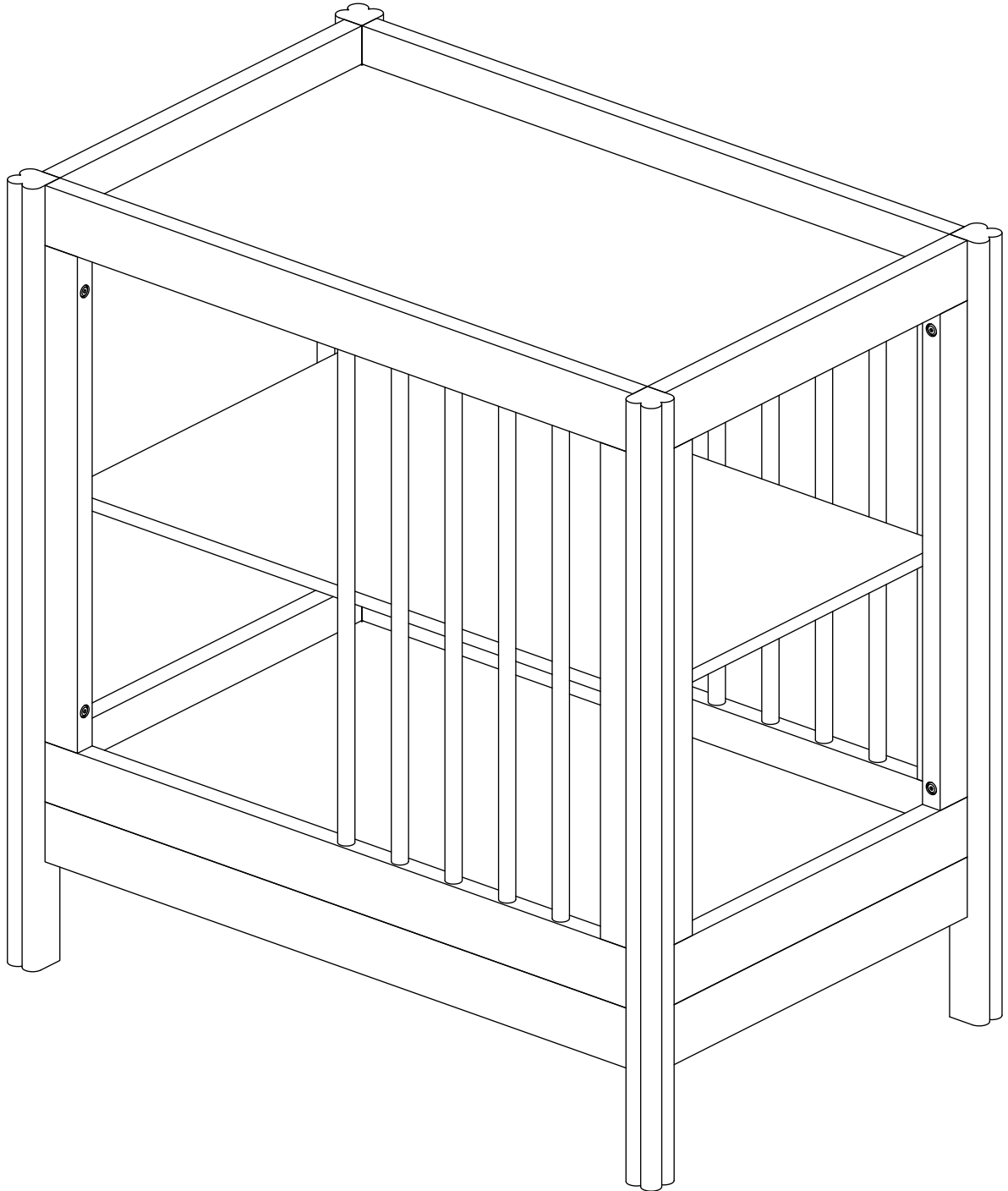

- The manufacturer's assembly instructions must be followed in detail to ensure the safety features to the change table are not compromise
- To clean surface use only water on a damp cloth. Do not use window cleaners or cleaning abrasives as it will scratch the surface and could damage the protective coating.

HARDWARE INVENTORY

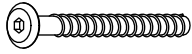

A. 60MM ALLEN HEAD BOLT
(24 PCS)



B. $\varnothing 6 \times 25$ MM WOOD DOWEL
(4 PCS)

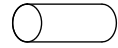

C. $\varnothing 10 \times 30$ MM WOOD DOWEL
(2 PCS)



D. SHELF SUPPORT
(4 PCS)

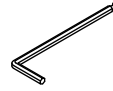

E. ALLEN WRENCH
(1 PC)

PARTS LIST

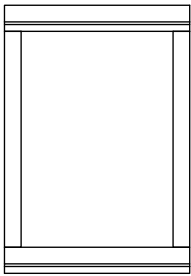

1. CRIB END
(2 PCS)

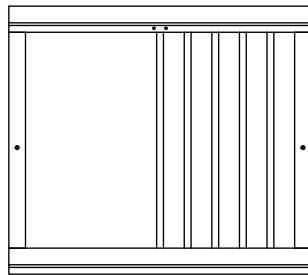

2. CRIB RAIL A
(1 PC)

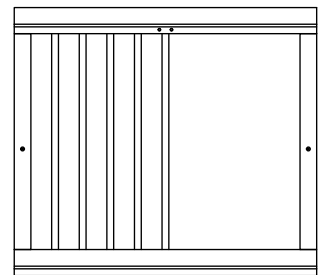

3. CRIB RAIL B
(1 PC)

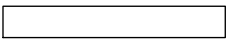

4. FRAME A
(2 PCS)

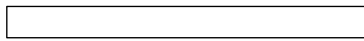

5. FRAME B
(2 PCS)

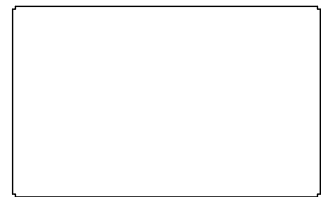

6. BOARD A
(2 PCS)

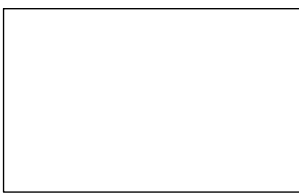

7. BOARD B
(1 PC)



8. TOP SUPPORT
(1 PC)

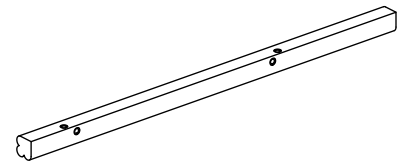

9. LEG A
(2 PCS)

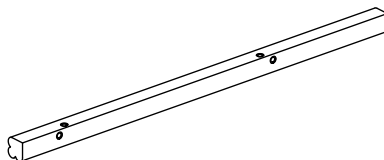

10. LEG B
(2 PCS)

STEP 1

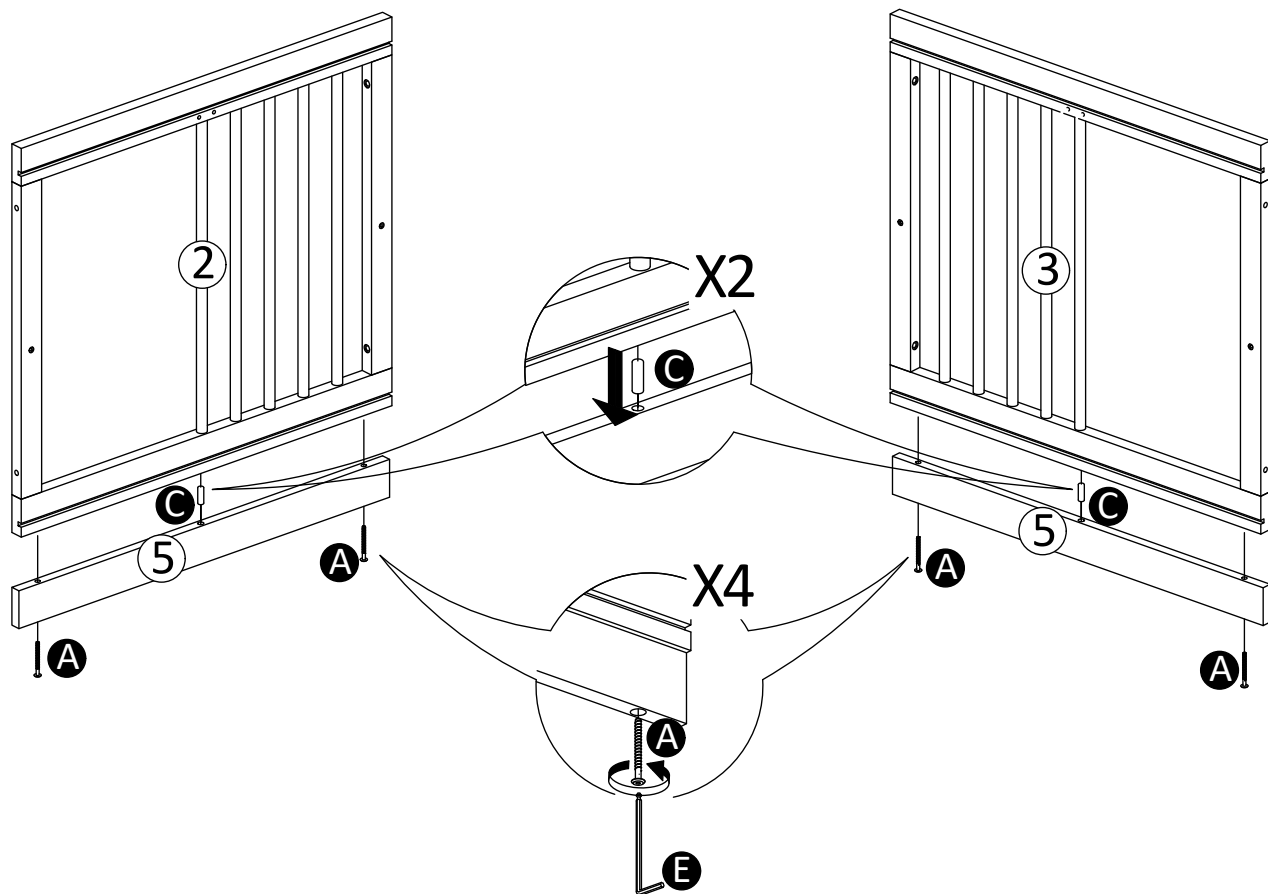

STEP 2

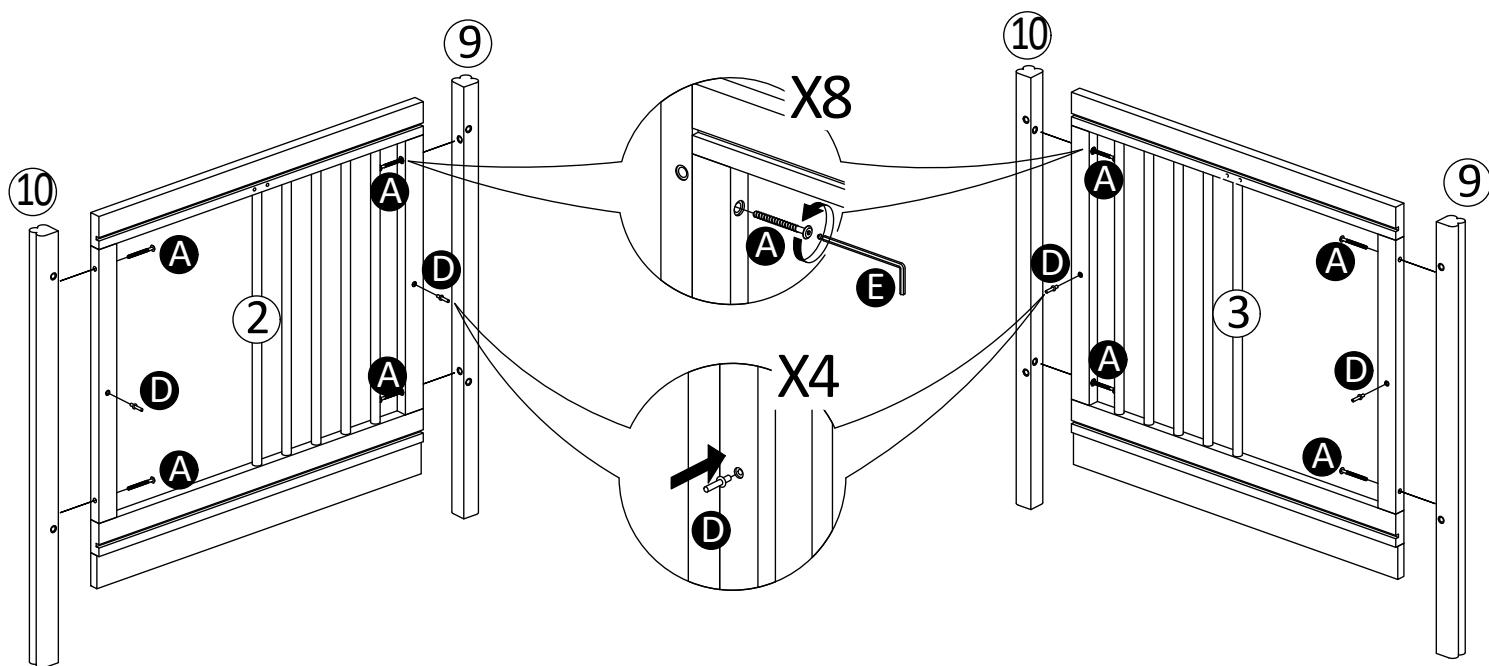

STEP 3

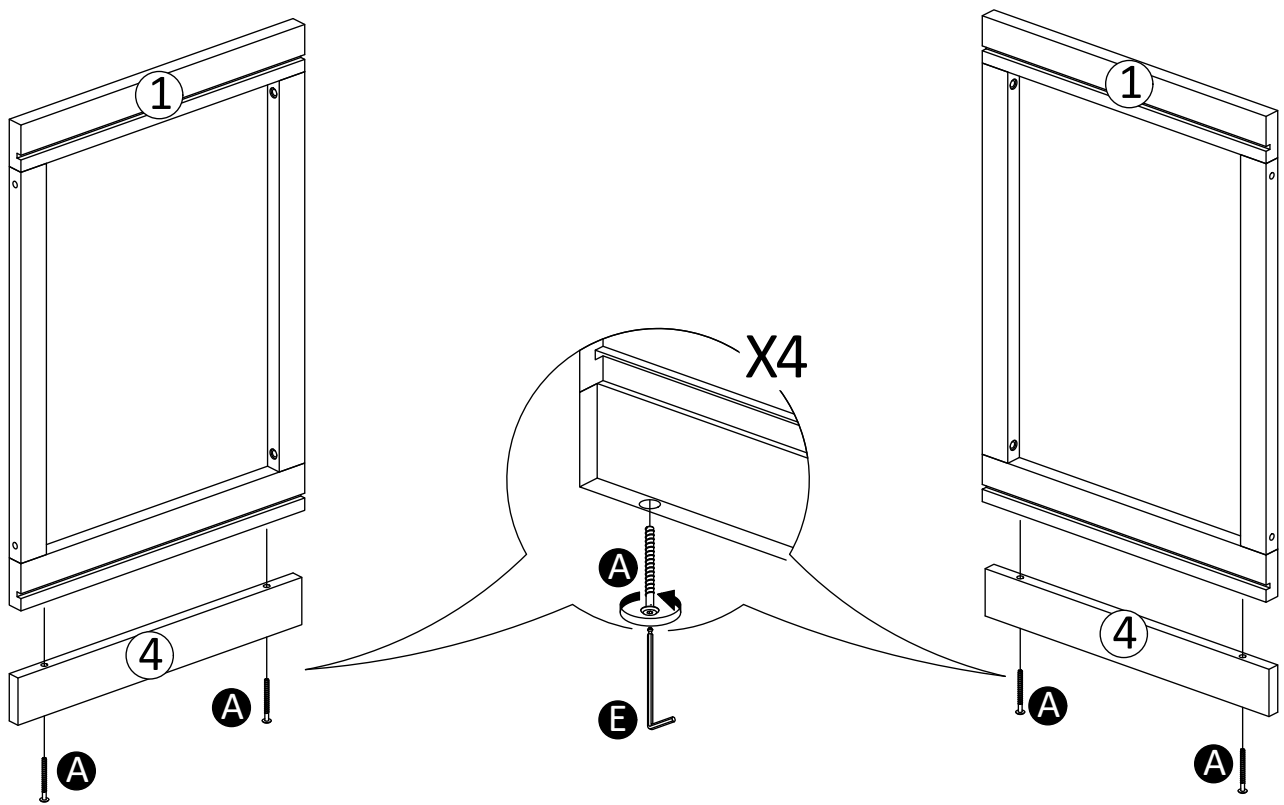

STEP 4

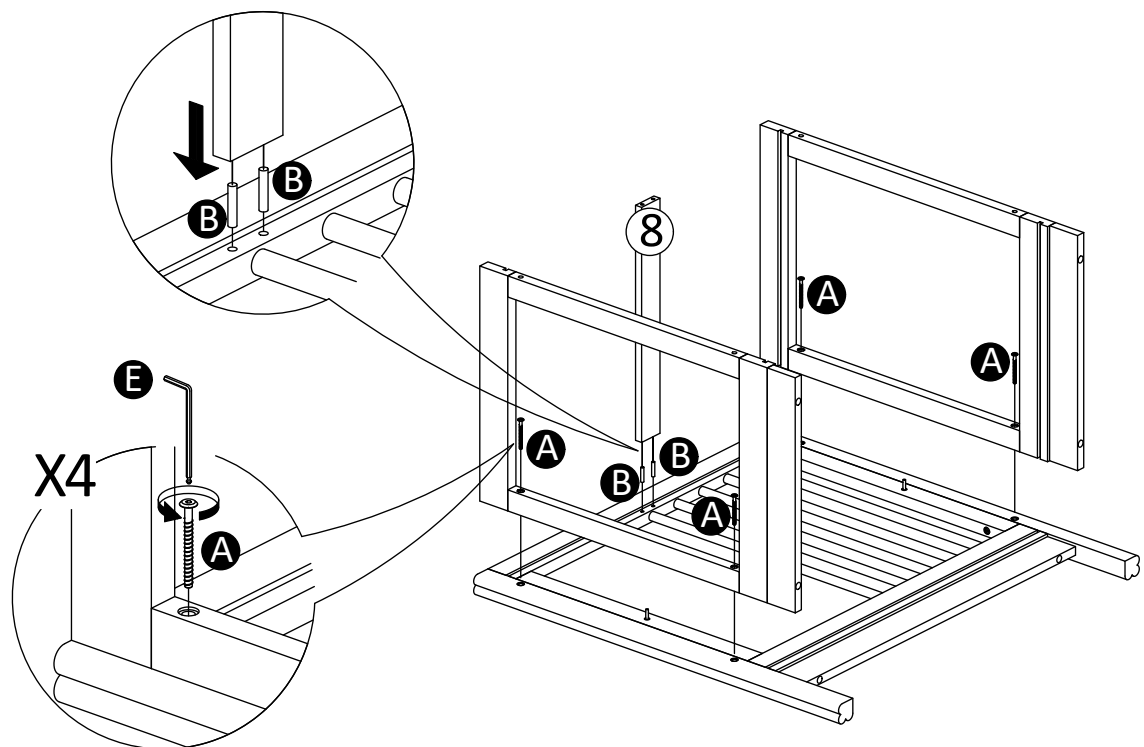

STEP 5

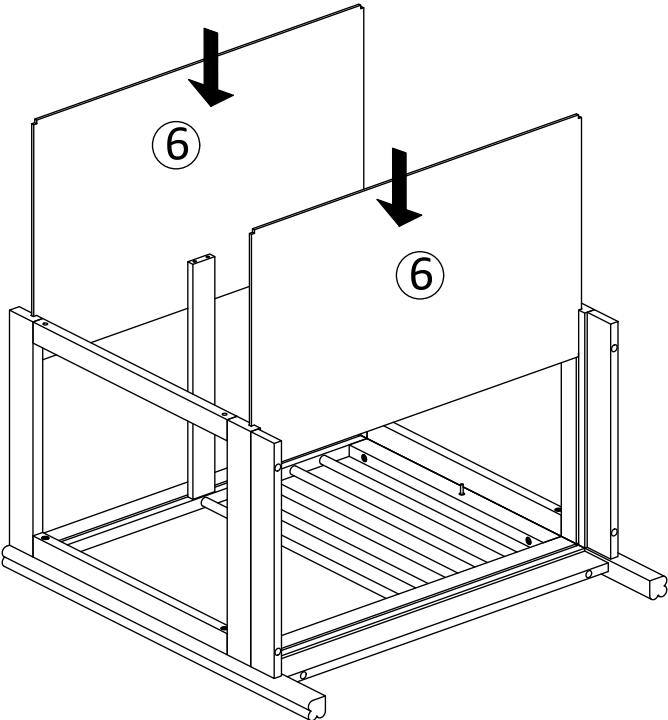

STEP 6

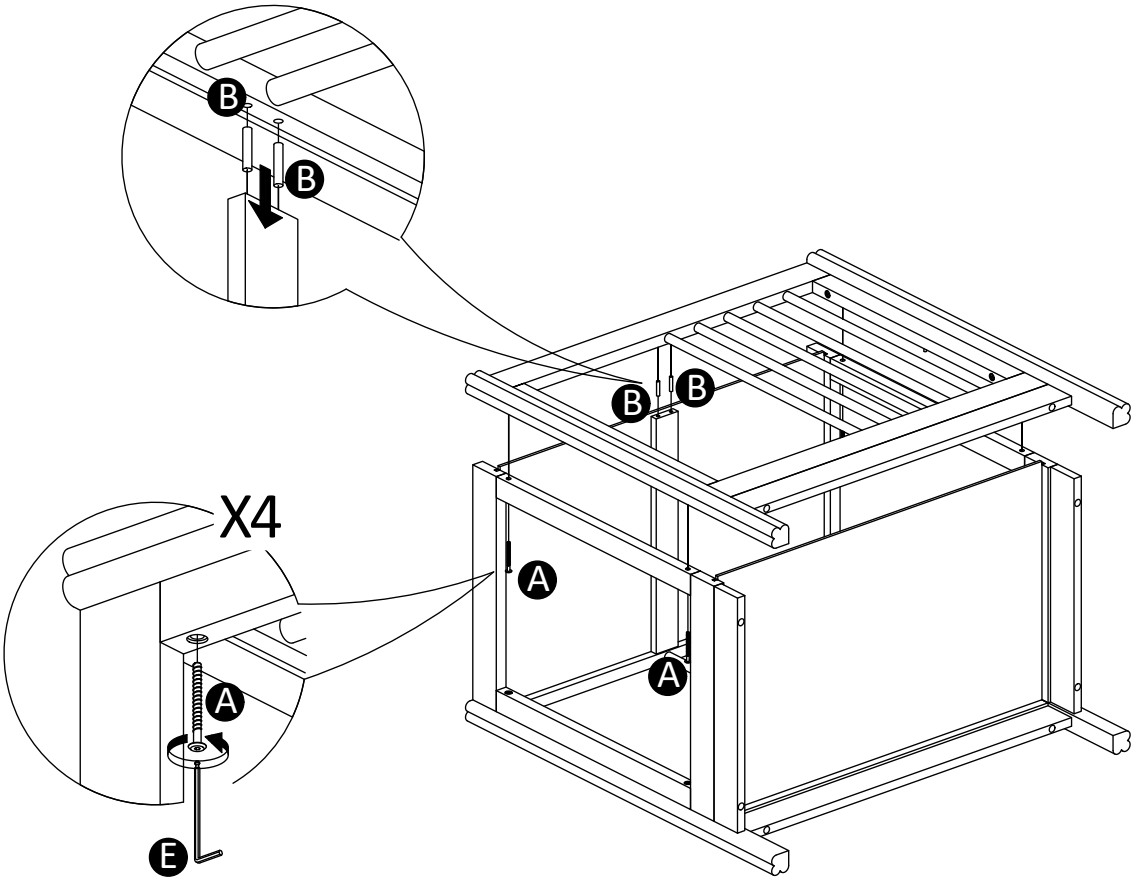

STEP 7

