







B2C FURNITURE

MODERN HARDWOOD FURNITURE

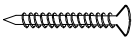
MYER 6 DRAWERS LOW CHEST ASSEMBLY INSTRUCTIONS

PARTS LIST			
No.	HARDWARE		Qty.
A	Dowel (8 x 30)		24
B	Dowel (6 X 30)		80
C	Screw (4 X 30)		51
D	Pan Head (3.5 X 16)		34
E	Anti Tipping Kit		1

PARTS LIST		
No.	PART LIST FOR FRAME	Qty.
1	Left side panel	1
2	Front Panel	1
3	Right Side Panel	1
4	Mid Partition between drawers	1
5	Back support bar w / 4 holes (for top)	1
6	Back support bar w/ no holes (bottom)	1
7	Top panel	1
8	Back Panel	1
No.	PART LIST DRAWERS	Qty.
10	Back Panel	6
11	Front Panel	6
12	Left Panel	6
13	Right Panel	6
14	Bottom Board	6
15	Under Support Bar	6

Assembly Tips:

Remove hardware from box and sort by the size parts and hardware for frame and drawers to check that all hardware and parts are present before assembling. Follow instructions below in proper sequence to ensure fast, easy and correct assembly.

DRAWER ASSEMBLY

Step 1

Insert Dowel B (6x30) into Drawer Front, Back panel and support rail

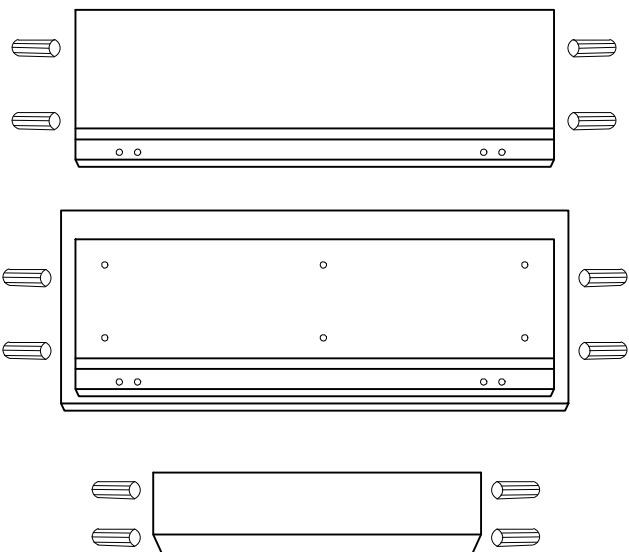

Step 2

Attach right side of drawer Part R to back Panel
Attach Middle support

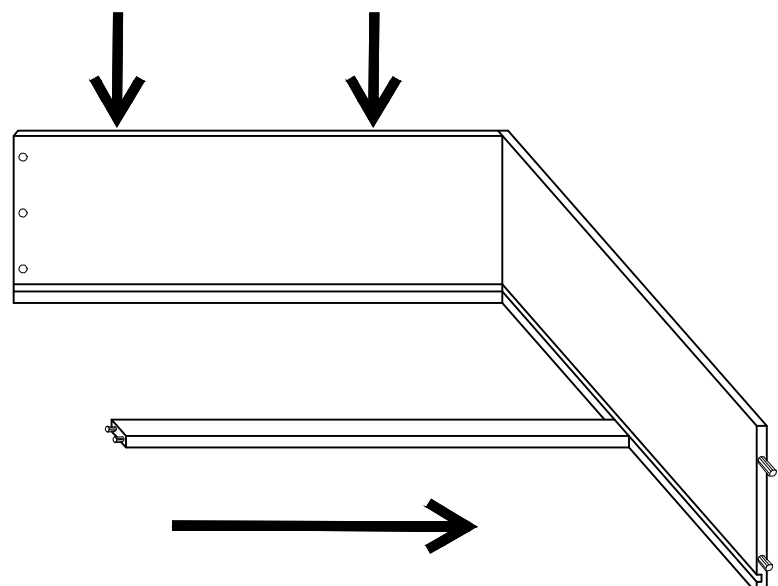

STEP 3

Attach Front drawer Panel and slide in base panel

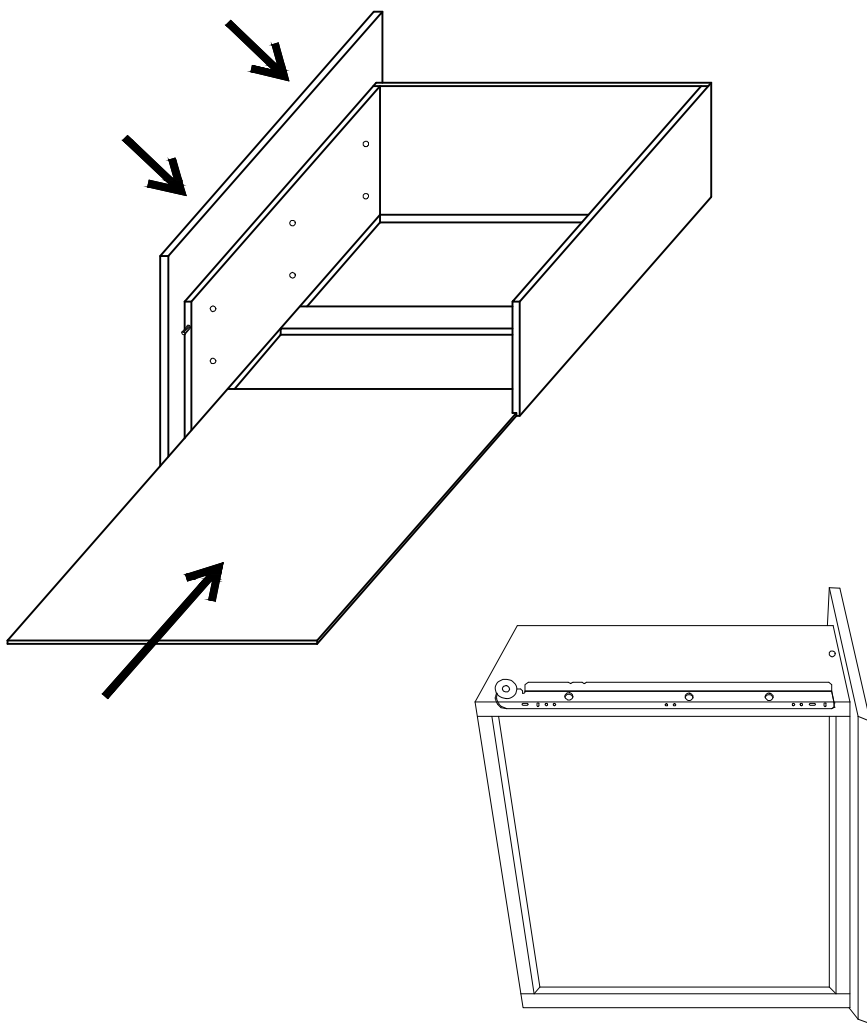

STEP 4

Attach left piece and screw together using Screw C (4x30)

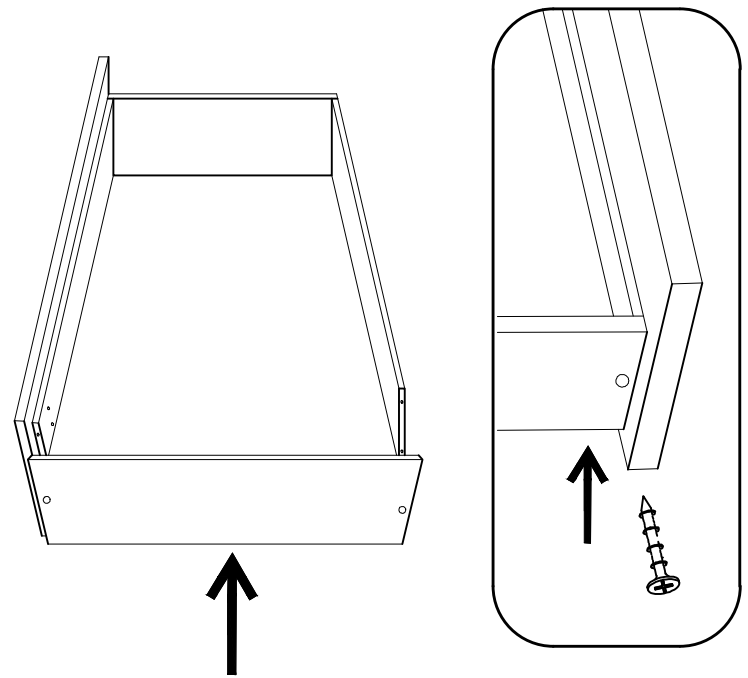

Drawer is complete.

Repeat steps 1- 4 for all 6 drawers

DRAWER ASSEMBLY

STEP 5

Insert Dowel (8 x 30) into part 1 and fix into Part 2 using Screw C (4 x 30)

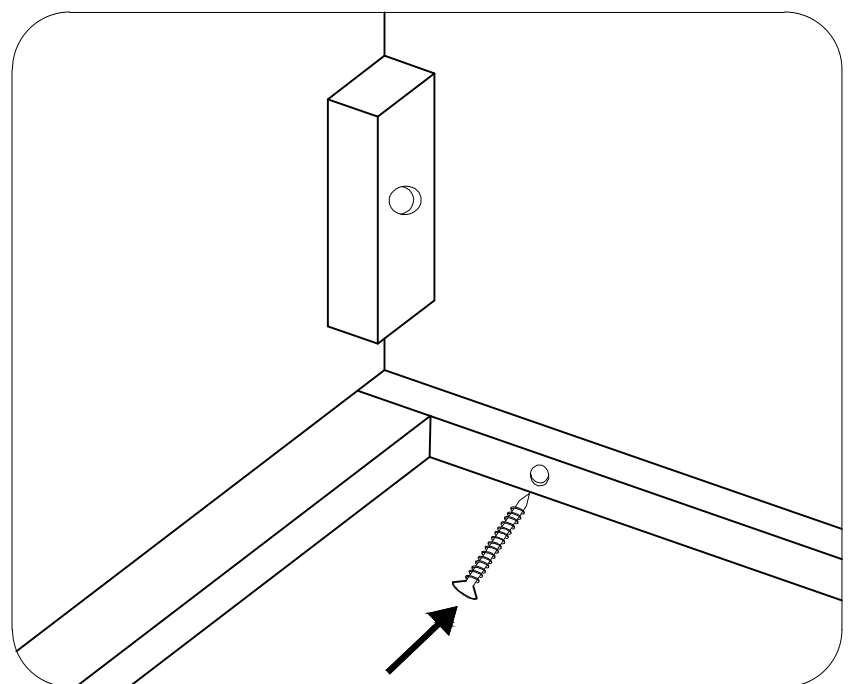
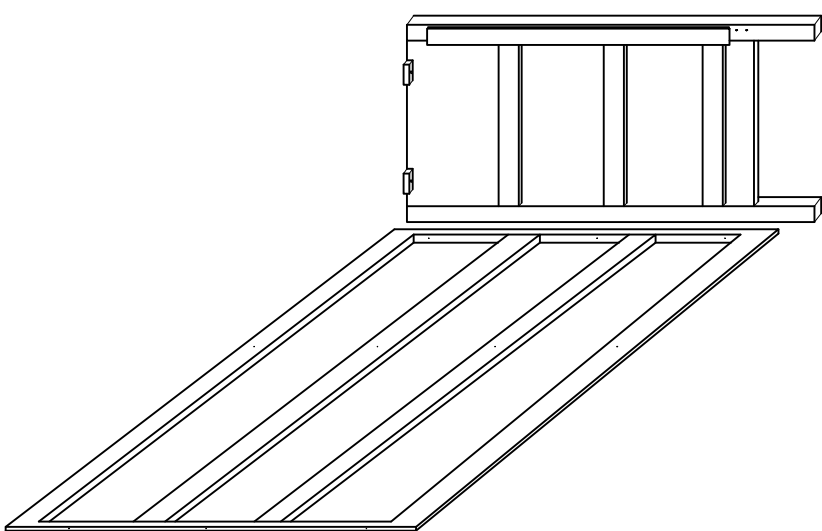

STEP 6

Insert part 4 fixing with Dowel A (8 X 30)

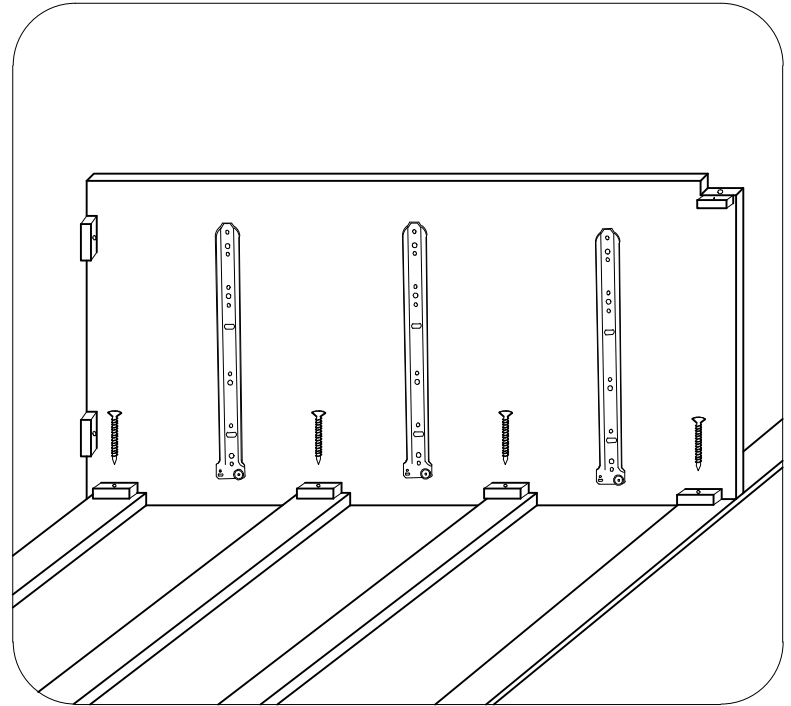
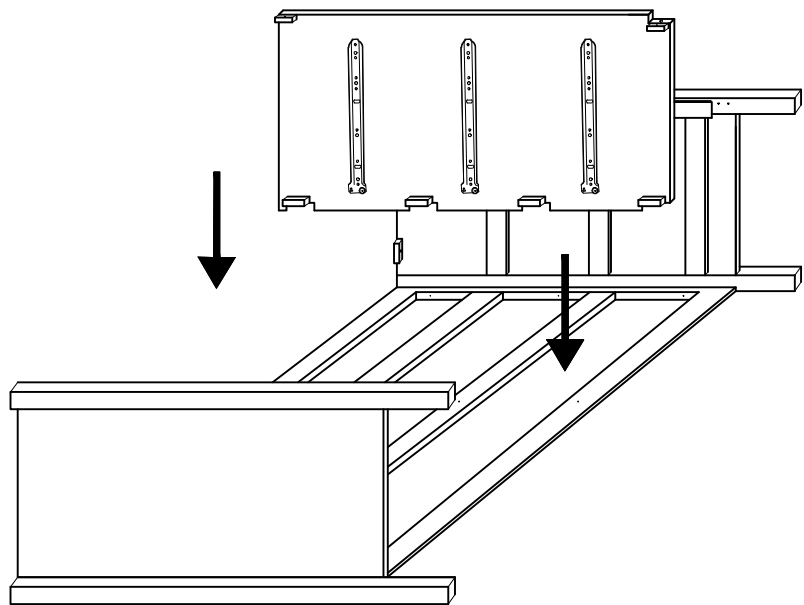

STEP 7

Insert Dowel A (8 x 30) into part 5 and 6

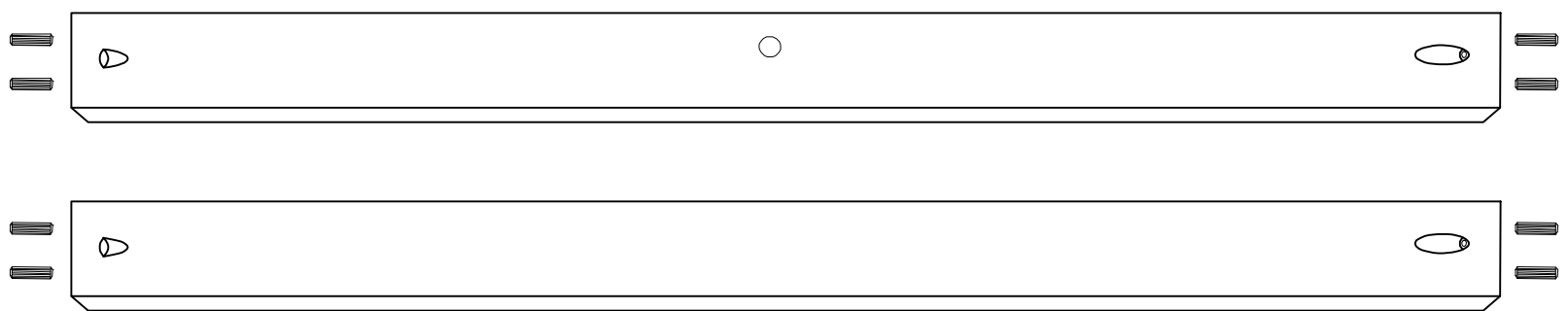

STEP 8

Attach Part 5 And 6 - Fix Using Screw C (4 x 30)

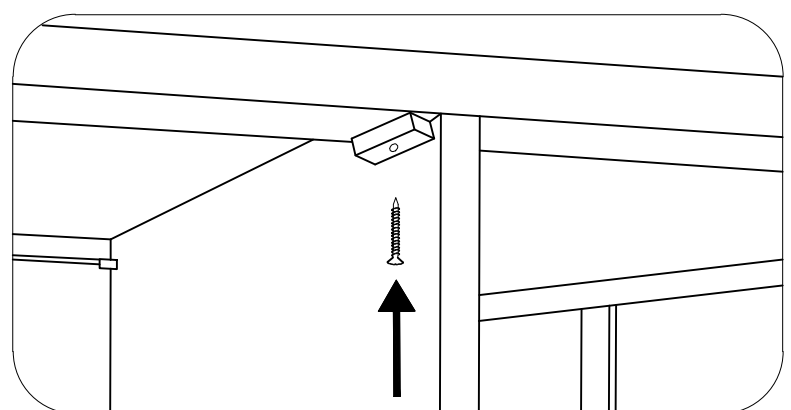
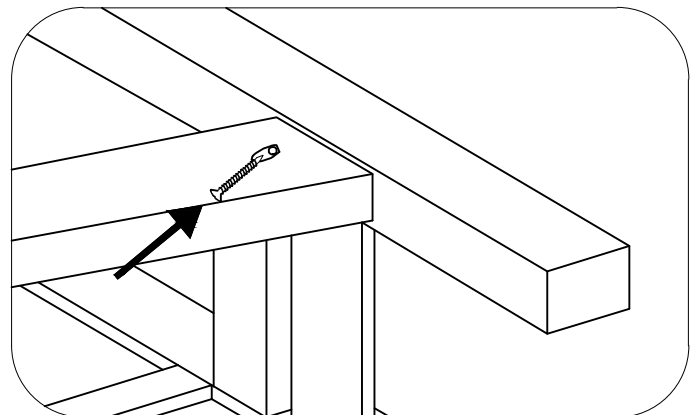
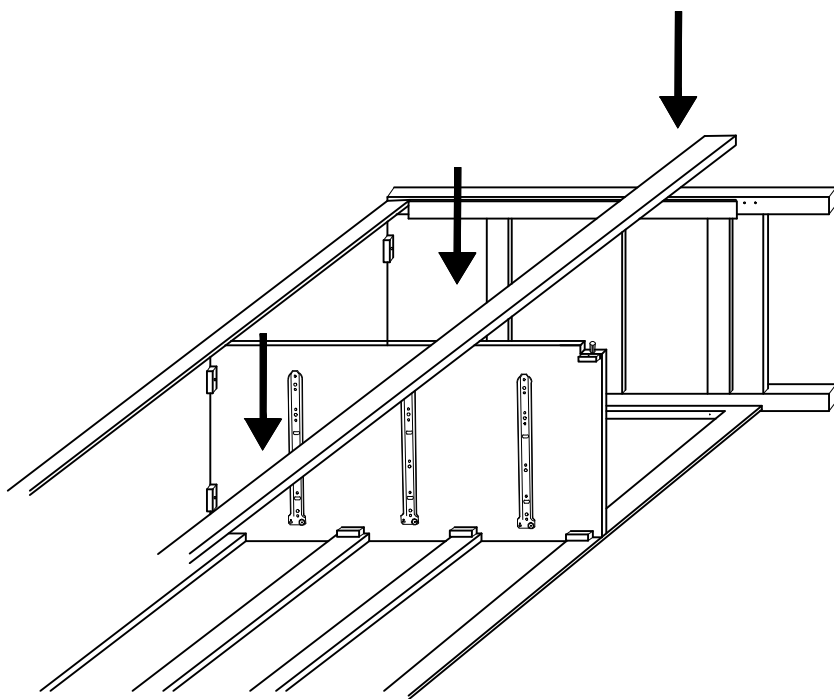

STEP 9

Attach Part 3 with Dowel (8 x 30)
Using Screw C (4 x 30)

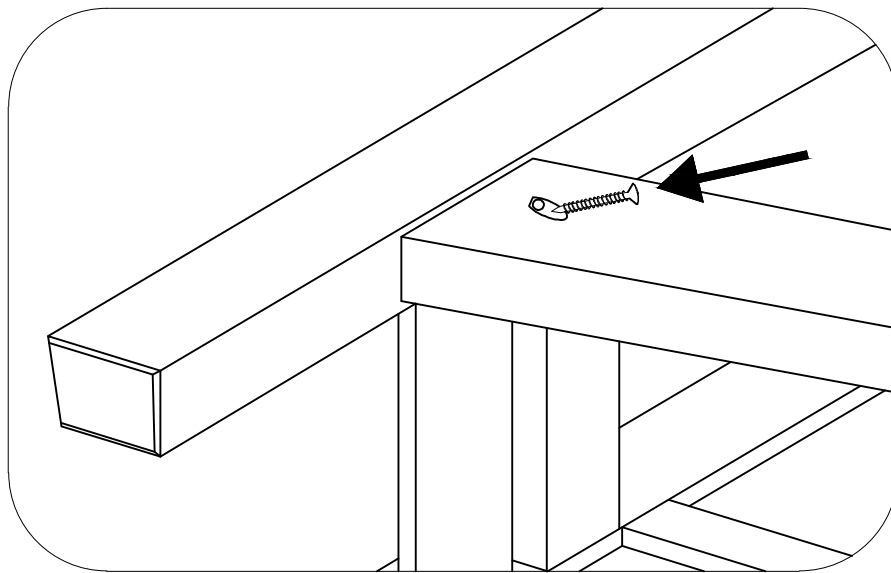
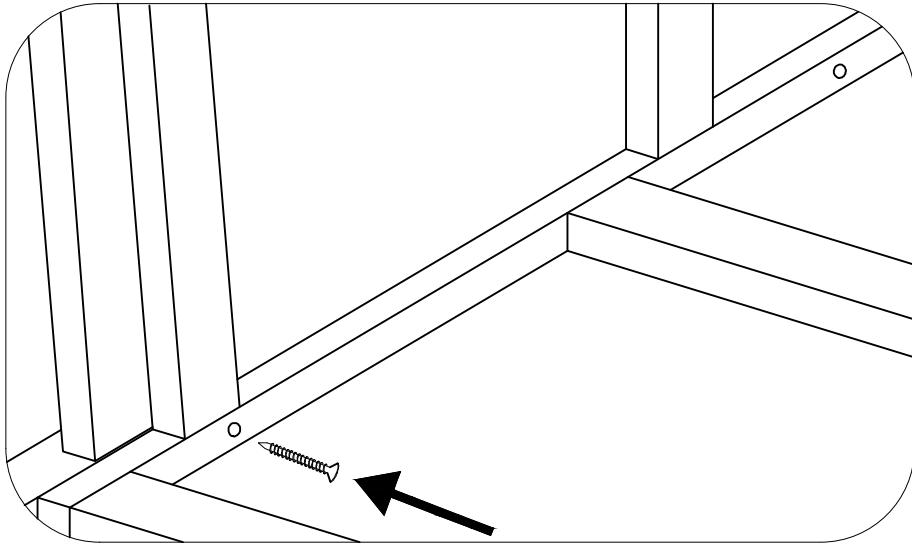

STEP 10

Attach the top using Dowel (8 x 30) and screw C (4 x 30)

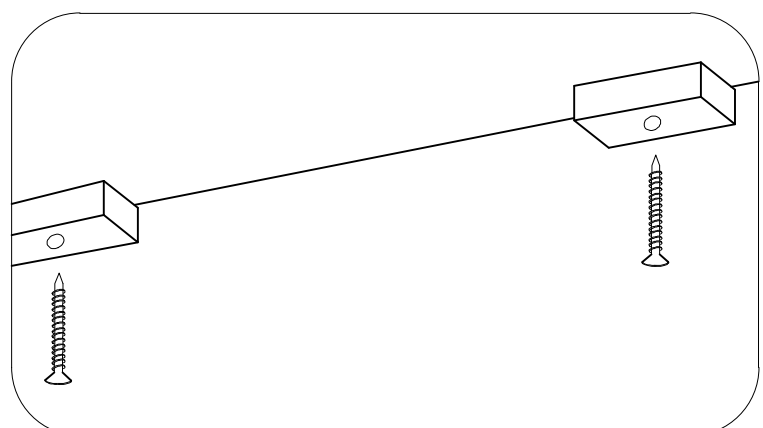
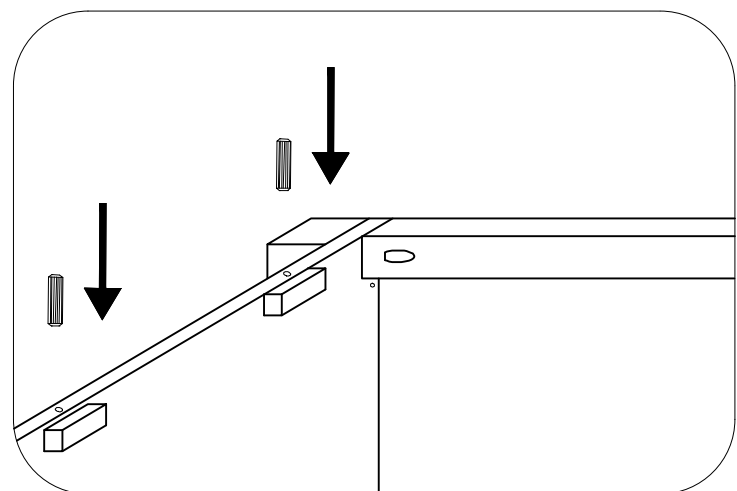
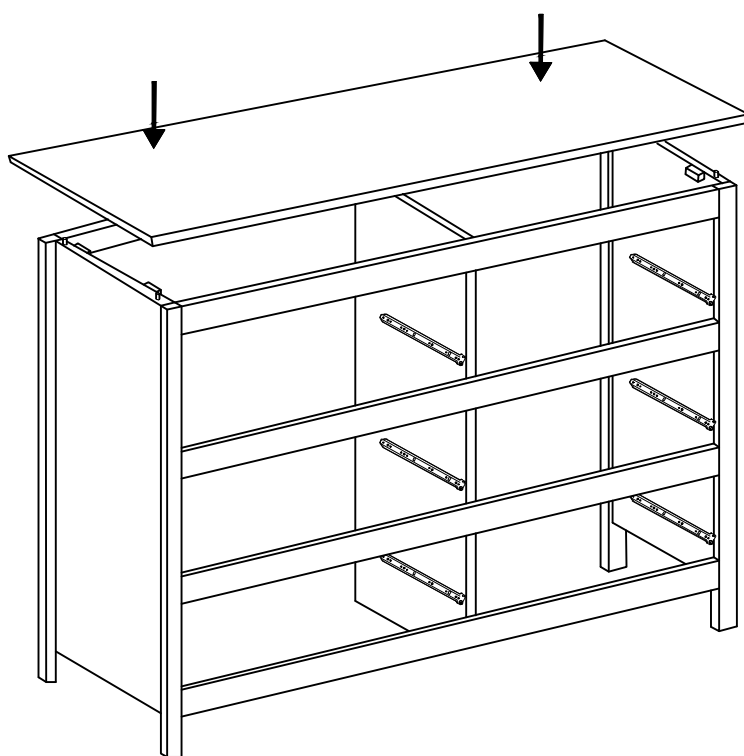

STEP 11

Attach Back Piece Part 8
using Screw D (3.5 x 16)

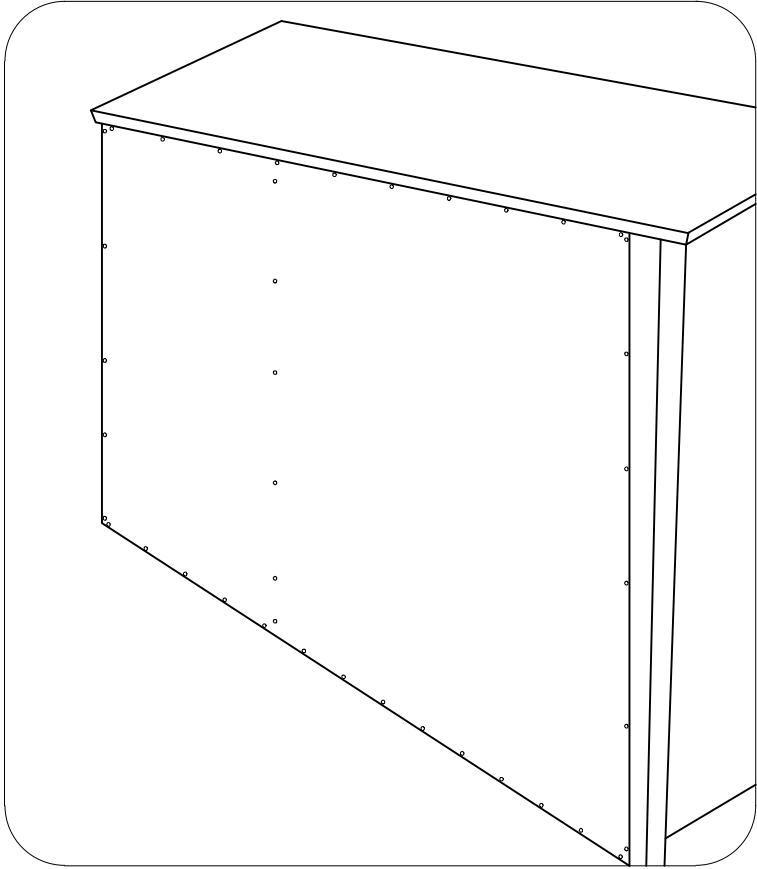

STEP 12

Inside Drawers into cabinet reconnecting
Drawer Runners

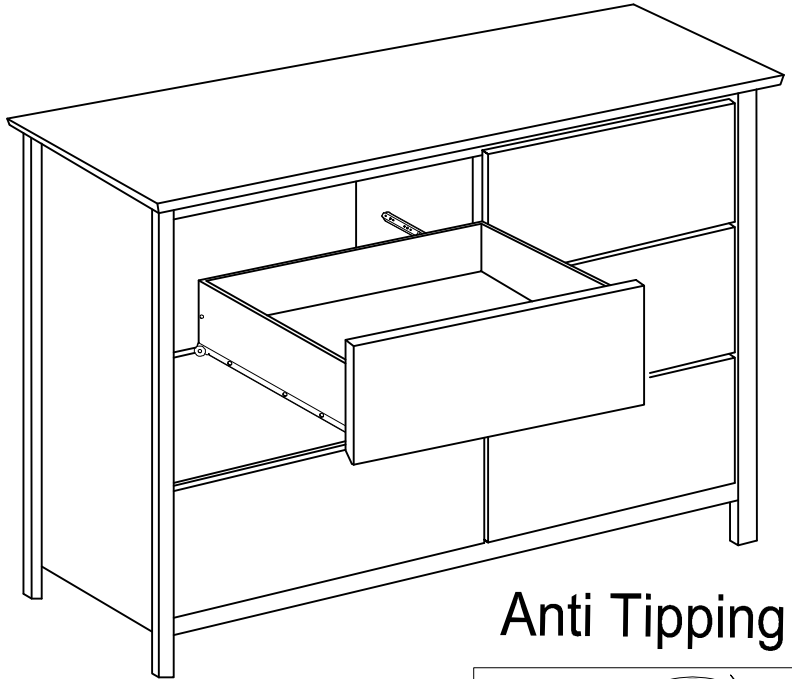

Anti Tipping

