

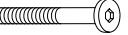





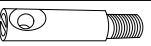
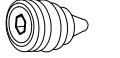

# ASSEMBLY INSTRUCTIONS

MODEL : DC1015

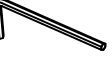
ITEM	PART NAME	QTY	ITEM	HARDWARE NAME	QTY
1	Leg R&L	2 PCS	A	JCBC BOLT M6 X 45 mm 	8 PCS
			B	SPRING WASHER M6 X 13 	8 PCS
2	Cushion Seat	1 PC	C	BARREL NUT (Short) 	2 PCS
			D	BARREL NUT (Long) 	2 PCS
3	Back Support	1 PC	E	BARREL NUT LOCK 	2 PCS
			F	PAN HEAD M4 x 32 mm 	4 PCS
4	Apron	2 PCS	G	ALLEN KEY M4 (Long) 	1 PC
			H	ALLEN KEY M5 	1 PC
			I	WOOD DOWEL M8 x 20 	2 PCS
			J	JCBC W M7 X 32MM 	2 PCS

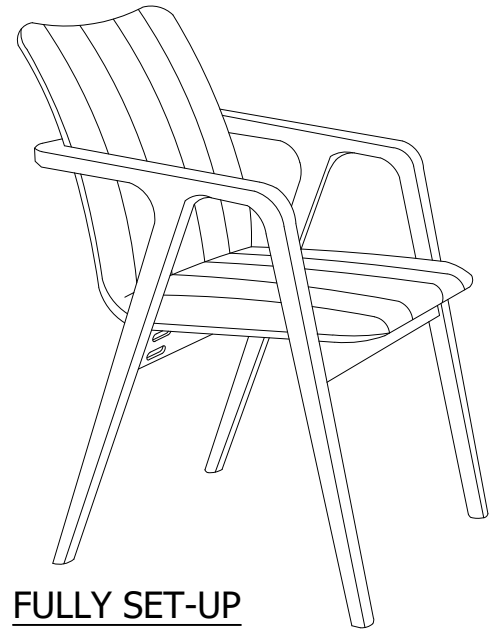

FULLY SET-UP

## Step 1

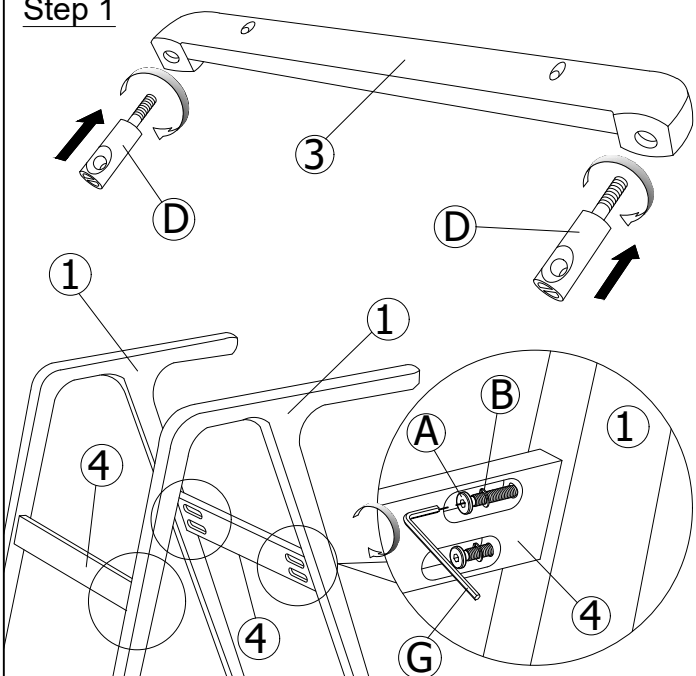

## Step 2

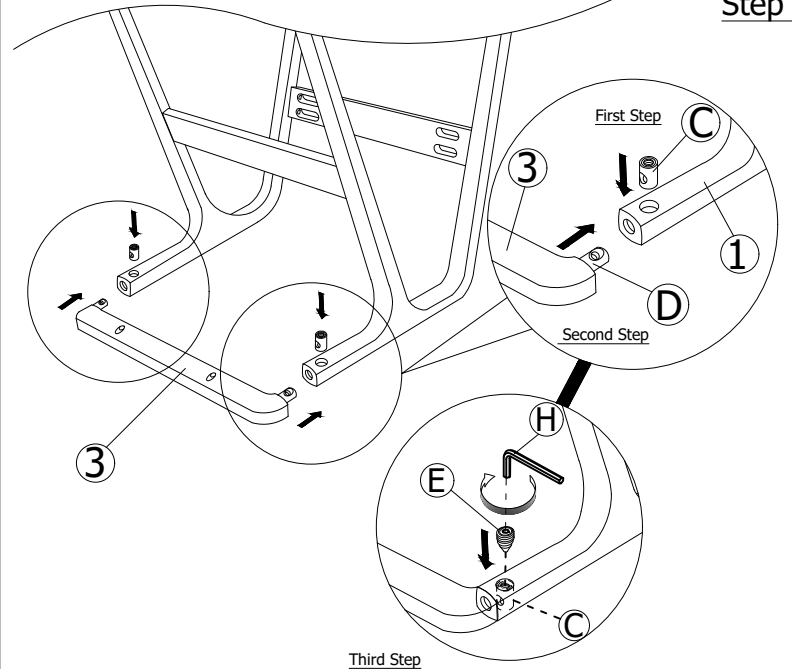

## Step 3

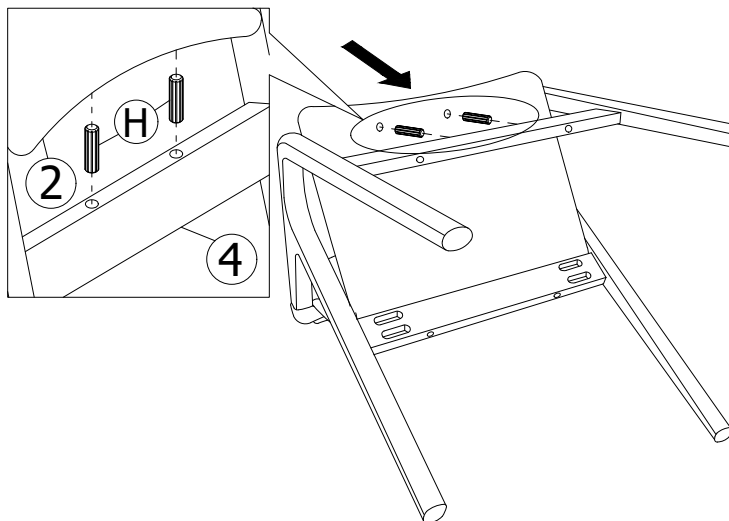

## Step 4

