



# Your Top to Bottom Manual

EAU BY TUSHY

Smart Toilet

 Your private think tank.

[HELLOTUSHY.COM](https://www.hellotushy.com)

# Eau yeah, that's the spot.

**EAU – PRONOUNCED "OH" – IS  
FRENCH FOR WATER.**

You didn't know it was possible to develop feelings for a toilet until now.

This instruction booklet will walk you (let's be honest, your plumber) through an easy step by step installation. Ready to put yourself on a pedestal?

## **Installation Videos & More:**

Scan the below QR code for a pre-install checklist, installation videos, TUSHY tunes, and much more!



[hellotushy.com/eau](https://hellotushy.com/eau)

## Table of Contents

4 Meet This Manual

---

5 Meet Eau by TUSHY

---

10 Before You Start

---

15 Prepare Your Bathroom

---

16 Connect Eau by TUSHY

---

29 Know Before You Go

---

31 How to Use Eau by TUSHY

---

38 Maintenance & Cleaning

---

40 Warnings & Safety

---

45 Troubleshooting

---

49 Limited Warranty

---

51 Contact Information

---

# 1 Meet This Manual

## Get into the groove.

Let's get this POTTY STARTED! Turn on some rump-shakin' TUSHY Tunes. We've assembled the perfect tracks to get you in the mood to upgrade your toilet, your booty, and your life.



[hellotushy.com/tunes](https://hellotushy.com/tunes)

## Use a buddy.

This toilet is heavy and requires careful positioning. We strongly recommend two adults for lifting and installation to prevent injury or damage.

## Have a question?

Our Customer Experience Poo-Rus are ready to help. Email [install@hellotushy.com](mailto:install@hellotushy.com), chat with us on [hellotushy.com](https://hellotushy.com), text MYTUSHY to 794-54 (US only) or +1 (888) 599-8926 (Canada only), or message us via WhatsApp at +1 (888) 218-8749.

\*By signing up via text, you agree to receive recurring automated promotional, personalized marketing text messages (e.g. cart reminders), and bumperful puns from TUSHY at the cell number used when signing up. Consent is not a condition of any purchase. Reply HELP for help and STOP to cancel. Msg frequency varies. Msg & data rates may apply. View Terms (<https://hellotushy.com/terms-of-use>) & Privacy (<https://hellotushy.com/privacy-policy>)

# 2 Meet Eau by TUSHY

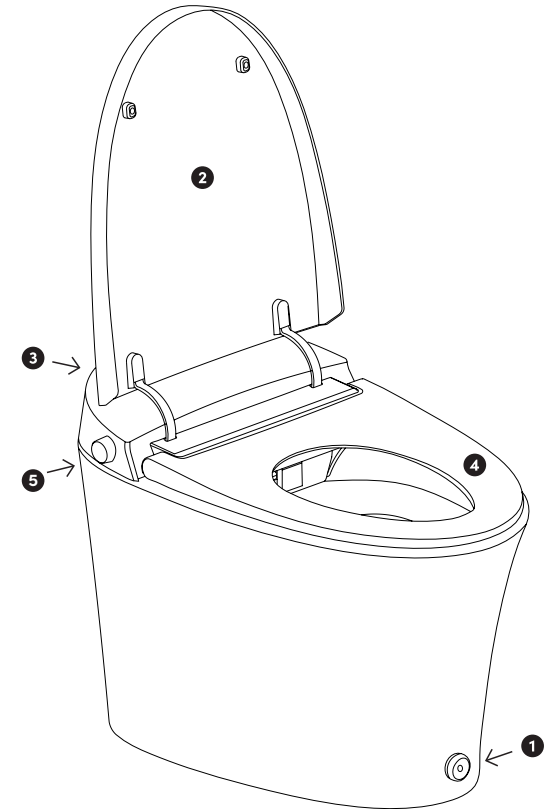

- 1 Kick Button
- 2 Auto Open/Close Lid
- 3 Cloud Spray Reservoir
- 4 Heated Seat
- 5 Side Control Knob

# Included Parts:



**Eau by TUSHY**  
(1x)

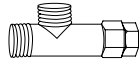

**T-Adapter with Built-In Filter**  
( $\frac{3}{8}$ " x  $\frac{1}{2}$ " x  $\frac{1}{2}$ " compression)  
(includes  $\frac{3}{8}$ " x  $\frac{1}{2}$ " adapter)

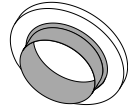

**Wax Ring**  
(1x)

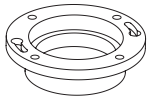

**3.5" Toilet Flange**  
(1x)

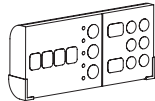

**Remote**  
(1x)

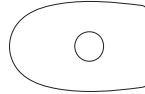

**Paper Mounting Template**  
(2x)



**AAA Batteries**  
(2x)



**Rubber Stopper**  
(1x)



**Cloud Spray Auto Foaming Cleanser**  
(Ships separately)

# Toilet Mounting Kit:

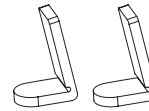

**Mounting Brackets**  
(2x)

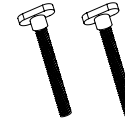

**Toilet Bolts**  
(2x)



**Washers**  
(2x)



**Nuts**  
(2x)

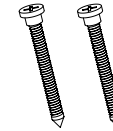

**Mounting Bracket Screws**  
(2x)



**Side Plugs**  
(2x)



**White Covers**  
(2x)



**Chrome Covers**  
(2x)

# Toilet Flange Mounting Kit:

OPTIONAL: ONLY IF INSTALLING A NEW FLANGE

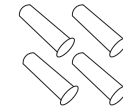

**Plastic Anchors**  
(4x)



**Flange Mounting Screws**  
(4x)

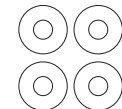

**Washers**  
(4x)

## Remote Holder Mounting Kit:

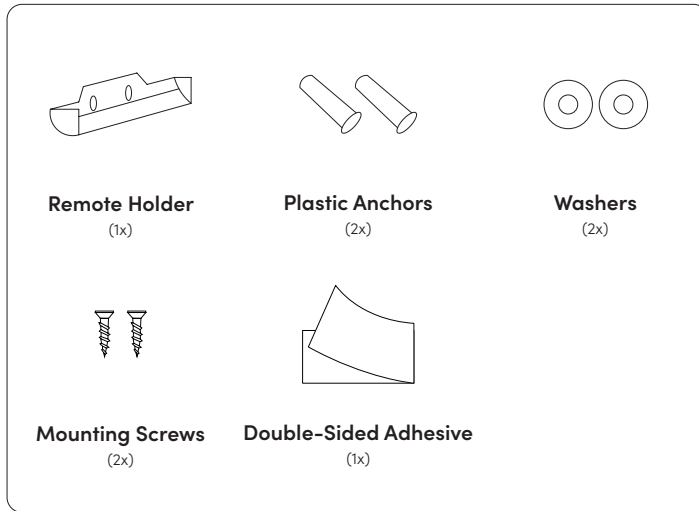

Scan this code to watch our Eau by TUSHY install video or go to [hellotushy.com/eau](https://hellotushy.com/eau)



### TUSHY TIP

Keep all parts and this manual – you may need them for future maintenance, repairs, or warranty claims.

## You'll Also Need:

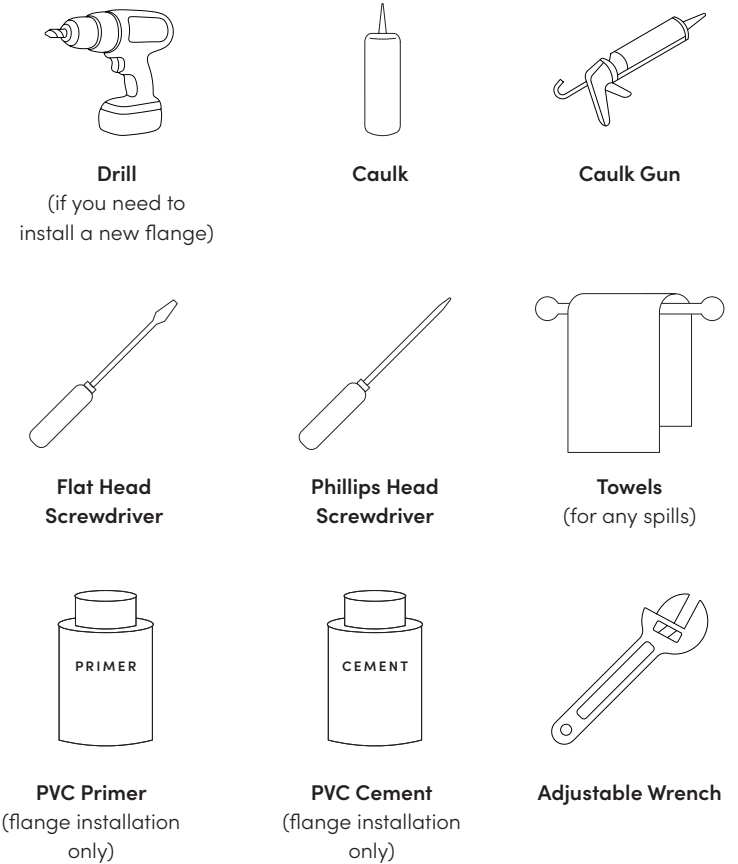

## 3 Before You Start

### **IMPORTANT: Inspect before installing.**

Carefully inspect the toilet for any cracks, chips, or damage to the porcelain before beginning installation. Check the bowl, tank, lid, and all porcelain surfaces under good lighting.

### **▲ If you find damage: ▲**



#### **STOP.**

#### **Do not install the toilet.**

Cracks or chips can worsen during installation and cause leaks or breakage. Contact us immediately to arrange a replacement.

### **Report damage within 3 days of delivery and before installation.**

Contact us by email, call, or text and include:

- Clear photo(s) or video showing the damage
- Photo of the product label showing the serial number (located on the right side of the toilet base)
- Order number
- Your full name
- Email used to place the order
- Phone number

Once damage is verified as warranty-eligible, we will arrange a replacement.

**▲ Damage reported after installation or outside the 3-day window will not qualify for warranty replacement. ▲**

### **Warnings and Safety:**

Read all instructions before installing or using your product. Do not install the toilet if there are any cracks, chips, or damage to the porcelain or components. Installing a damaged product could result in leaks, breakage, or property damage. Always turn off the water supply valves before installing or performing maintenance on your product.

### **Tighten carefully**

When tightening connections, make sure they are finger tight, but be careful not to overtighten as this could result in leaks or property damage. Make sure you check for leaks after installing your product and periodically thereafter.

### **Questions?**

If you're not sure about something, please consult a plumber or send us an email at [install@hellotushy.com](mailto:install@hellotushy.com)

# Check Your Power Outlet

**▲ WARNING ▲** Failure to read this may result in serious injury or death from electric shock. This product requires a 3-prong 120V GFCI outlet.

Check that your outlet is within 3 feet of the toilet – the power cord is 3 feet long. Your outlet should match the GFCI outlet shown on the left (checkmark). If your outlet looks like the example on the right, do not proceed.

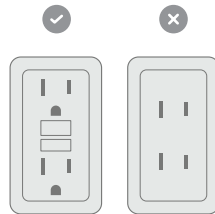

Need a GFCI outlet installed? We can refer you to a licensed electrician in your area – contact us at [install@hellotushy.com](mailto:install@hellotushy.com)

# Check Your Toilet Setup:

## 1 Rough-In

Center of the drain pipe must be at least 12" from the wall.

### Required clearances:

- Minimum 12" of clear space behind the toilet bowl
- Minimum 8" from the center of the drain pipe to any side wall or obstacle
- Minimum 12" of clear space in front of the toilet bowl

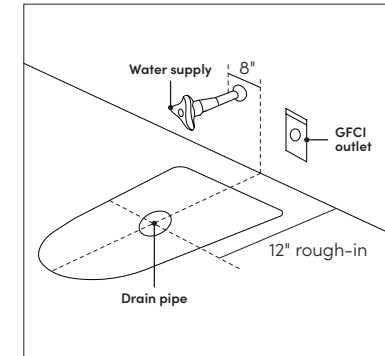

## 2 Water Connection

The water supply valve must be at least 8" to the left or right from the center of the drain pipe.

**Valve compatibility:** Your existing water valve must have a  $\frac{3}{8}$ " or  $\frac{1}{2}$ " compression fitting. If your valve does not have this type of connection, you will need to install a compatible valve before proceeding with installation.

Not sure what type of fitting you have? Look for a small nut where the supply line connects to the valve – if it screws on, it's likely compression.

## 3 Power Connection

The included power cord is 3 feet long – ensure your GFCI outlet is within reach.

**▲ IMPORTANT: ▲** Confirm all three requirements are met before beginning installation. If any are not met, do not proceed – modifications to your plumbing or electrical setup will be required first.

**STEP 1****Place Paper Mounting Template and Verify Fit**

Place the installation template on the floor and trace the outline with a pen or pencil to confirm the rough-in dimensions. Remove the template before installing the unit. This template matches the exact size and dimensions of the product base.

**STEP 2****Confirm Product Dimensions in Your Space**

Use the diagrams below to verify the toilet will fit in your bathroom with proper clearance on all sides. Reference page 13 to check your toilet setup.

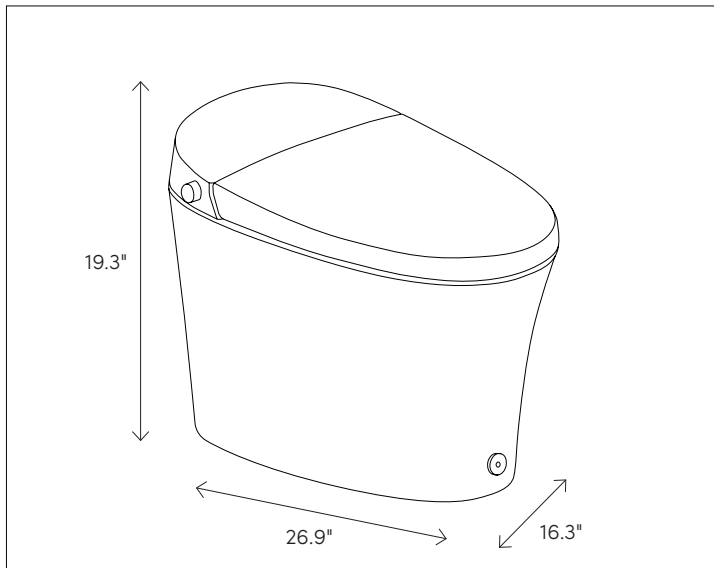
**4 Prepare Your Bathroom****STEP 1****Turn off your water supply valve.**

Turn off the water supply valve beside the toilet by turning it clockwise.

**▲ CAREFUL ▲** Turn slowly and steadily – forcing a stiff valve can damage the fitting.

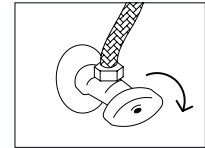
**TUSHY TIP**

If the valve is tight, there may be some mineral buildup. Try twisting in one direction and then the other, each time rotating a little further until it's free to turn all the way around.

**STEP 2****Disconnect the Water Supply Hose**

Disconnect the existing flexible steel hose from the angle valve by turning it counter-clockwise.

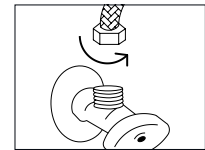
**STEP 3****Clear the Floor**

Clear the floor of any debris or residue left from the previous installation.

**STEP 4****Clean Existing Flange (if applicable)**

If you removed an existing toilet and will be using the previously installed Toilet Flange, make sure to clean up and remove any leftover wax from the previous Wax Ring.

**TUSHY TIP**

If reusing an existing flange, confirm it sits flush or slightly above the floor level – this ensures a proper seal.

# 5 Connect Eau by TUSHY

**TUSHY TIP**

**▲ USE A BUDDY ▲** The product is very heavy and can be difficult to maneuver and cause injury!

Already have a toilet flange installed?  
Skip to Step 2. No flange yet? Start here.

**STEP 1** Install the Toilet Flange.

**A** Check to make sure the included Toilet Flange fits your existing plumbing by placing it on your existing pipe.

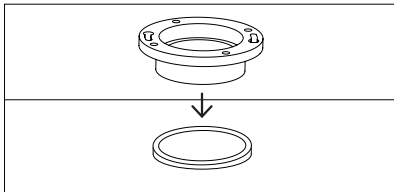

**B** Apply PVC primer to the inside of the pipe first. While primer is still wet, apply PVC cement.

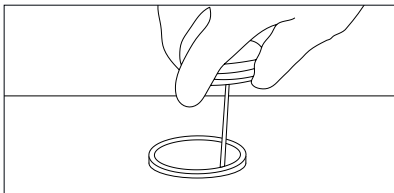

**C** Apply PVC primer to the outside of the flange. While primer is still wet, apply PVC cement.

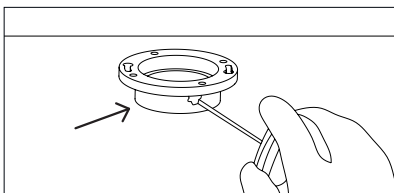

**D** Orient the flange so the open slots on the ring face toward the wall (as shown). This ensures the toilet bolts will line up correctly with your toilet base.

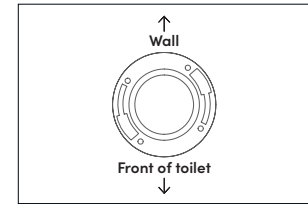

**E** Press the Toilet Flange firmly onto the pipe and hold for the time specified on your PVC Cement packaging.

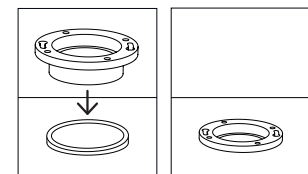

**F** Insert the provided Flange Mounting Screws through the holes in the Toilet Flange and into the floor.

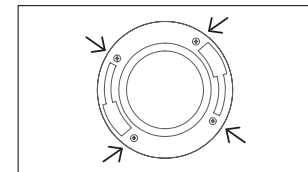

**TUSHY TIP**

If you have a concrete floor, use the included Plastic Anchors first – tap them into pre-drilled holes before inserting the screws.

**STEP 2** Install Mounting Brackets

**A** Use the provided Toilet Bolts and slide them into the correct position as shown below. Do not fully position them at the end of the slot. Make sure each toilet bolt is directly opposite from each other.

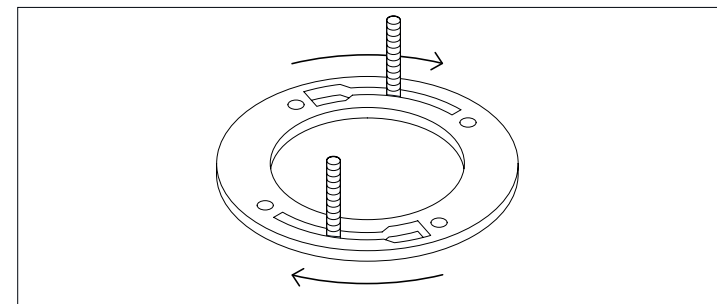

- B** Place Mounting Brackets over the Toilet Bolts.
- C** Place the Washer over each Toilet Bolt, then thread the Nut on by hand. Tighten until snug – hand-tight only, do not use tools yet.

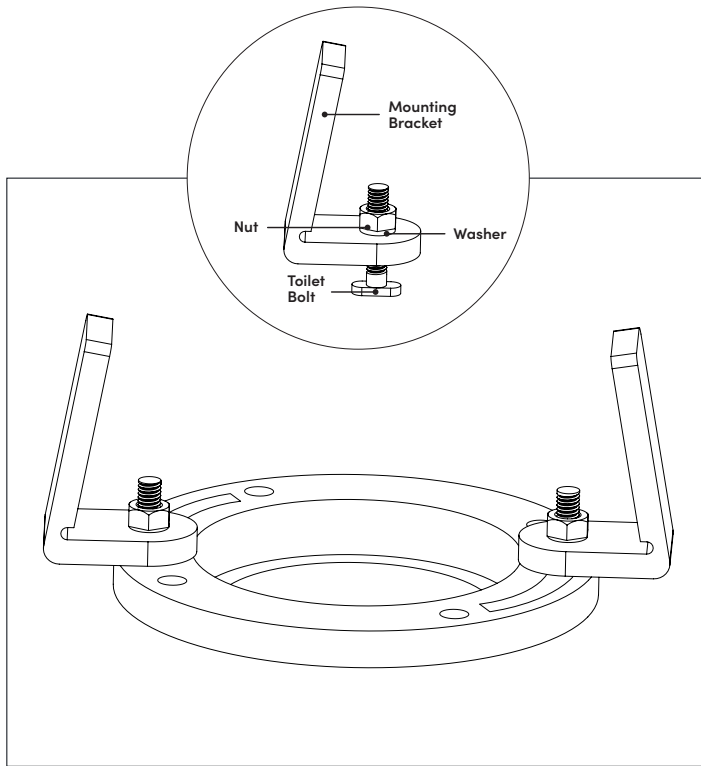

**TUSHY TIP**

If you temporarily plugged the drain opening to block sewer odors, remove the plug now before placing the toilet.

**STEP 3** Install the Wax Ring.

- A** **▲ Two people required for this step. ▲** Carefully tip the product over, exposing the underside of the toilet.
- B** Place the amber (wax) side against the toilet horn, with the black ring facing outward toward the floor. The wax side creates the seal.

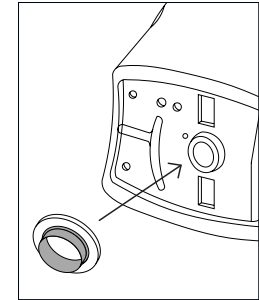

**STEP 4** Place and set the toilet.

- A** **▲ Using two or more people, ▲** Carefully lift up the toilet and place it over the Mounting Brackets on the Toilet Flange. Align the Mounting Brackets with the toilet. If the toilet does not sit flush, lift it clear and re-check that the Mounting Brackets are aligned with the mounting holes before lowering again. Do not force it down.
  - B** Once the toilet is aligned with the Mounting Brackets and does not shift around, press down firmly and evenly on the toilet base to fully compress the Wax Ring and create a watertight seal.
  - C** Insert the Side Plugs into the holes on the side of the toilet near the Mounting Brackets.
  - D** Insert the Mounting Screws into the Side Plugs. Use a Phillips Screwdriver to fasten the Mounting Bracket Screws into the Mounting Bracket. This will secure the toilet.
- ▲ Be careful not to overtighten as damage or cracking may occur. Do not use a drill. ▲**

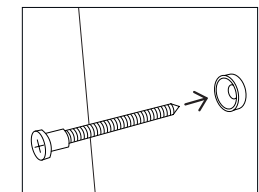
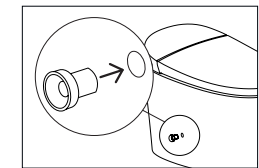
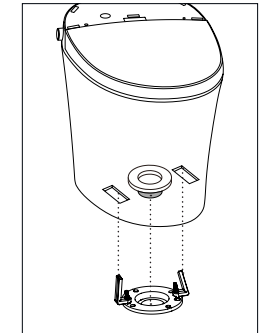

**E** Once toilet is secure, place the Covers over the Mounting Screws.

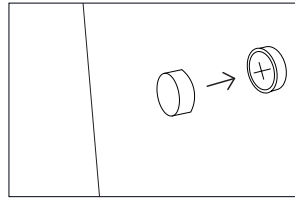

## STEP 5 Install the T-Adapter with Built-In Filter

Check to ensure the black rubber gasket is inside the T-Adapter.

Install the T-Adapter with Built-In Filter onto your water supply valve, turning clockwise by hand first, then snug with a wrench — do not overtighten. If your valve has a ½" compression thread, remove the step-down adapter by rotating it counterclockwise before installing.

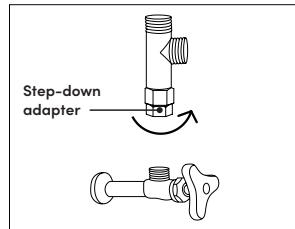

## STEP 6 Connect the hoses.

**A** Connect the Flush Water Supply Hose to the side connection of the T-Adapter with Built-In Filter by turning clockwise with a wrench.

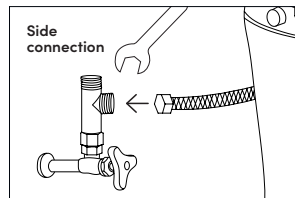

**B** Connect the Bidet Water Supply Hose to the top of the T-Adapter with Built-In Filter by turning clockwise with a wrench.

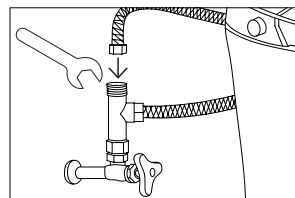

**▲ Hand-tighten both hoses first, then snug with a wrench. Do not overtighten either connection. ▲**

## STEP 7 Turn on the water and check for leaks.

**▲ Do not skip this step. Undetected leaks can cause water damage to your floor and subfloor. ▲**

Turn the water valve on and off slowly one time to check the water connections for any leaks. Be sure to touch each hose to ensure water isn't running down them. Once there are no leaks, make sure your water valve is open, leave a towel or a bowl below the connections, and check back in an hour to ensure there are no slow leaks that may not be instantly visible.

If you are experiencing leaks:

- Make sure the hose and adapter threads are aligned properly.
- Make sure the hoses and adapters are tightened completely, but remember not to overtighten!
- Run a flush cycle and check for water around the base of the toilet. If you see water, the Wax Ring may not be properly sealed to the Toilet Flange. If a leak is present, return to Step 3 and inspect the Wax Ring installation.

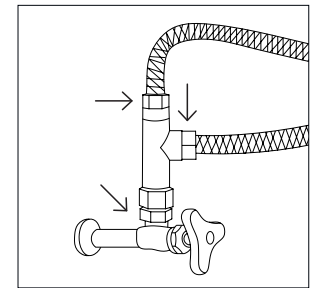

If there is any water present after an hour, repeat the steps above. If not, you are good to go!

**▲ WARNING ▲ If leaks persist, turn off the water supply valve and refer to the Troubleshooting section (p. 45) before proceeding. Do not leave slow drips unaddressed — they can cause significant water damage over time.**

**STEP 8****Fill the Cloud Spray Reservoir.**

**A** Remove the toilet cover by lifting from the indent at the back of the toilet.

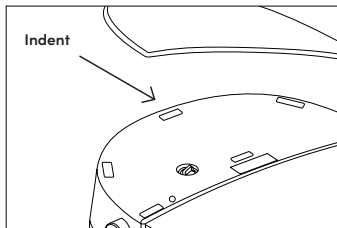

**B** Remove the Rubber Stopper shown from the Cloud Spray reservoir.

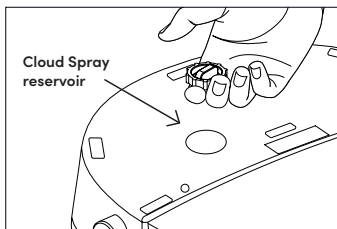

**C** Pour the entire bottle of Cloud Spray cleanser into the reservoir.

**TUSHY TIP**

Using a funnel will prevent any accidental spillage.

**D** Replace the Rubber Stopper back into the Cloud Spray reservoir.

**E** Replace the toilet cover, aligning it with the indent at the back until it sits flush.

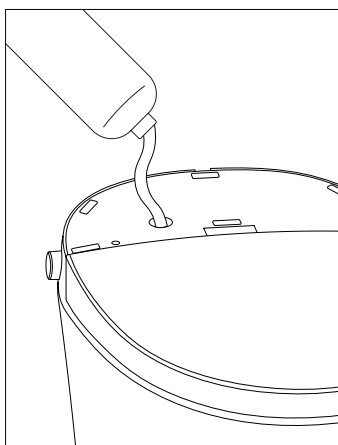
**STEP 9****Grounding Instruction**

**▲ DANGER ▲ Electric Shock Risk. Improper use of the grounding plug can result in serious injury or death. Refer to Warnings & Safety (p. 40) before proceeding.**

This product has a 3-prong grounding plug, which must be plugged into an outlet that is properly installed and grounded. In the event of an electrical short circuit, grounding reduces the risk of electric shock by providing an escape wire for the electric current. If repair or replacement of the cord or plug is necessary, do not connect the grounding wire to either flat blade terminal. Check with a qualified electrician if you don't understand the grounding instructions, or if you're not sure whether the product is properly grounded. Eau by TUSHY is intended for use on a nominal 120V 60 Hz circuit and has a grounding plug that looks like the receptacle below.

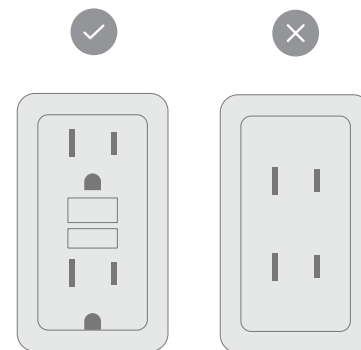

## STEP 10 Plug it in!

Once the connections are leak-free and the area around the toilet is dry, plug the power cord into the 3-prong 120V GFCI outlet.

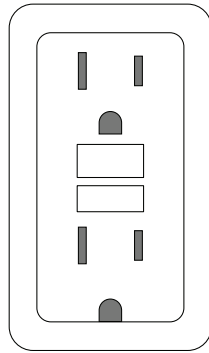

Once plugged in, the toilet will run a self-diagnostic cycle – this is normal. The lights will turn on, the nozzle will extend briefly, and water will run through the system. The display will show any error codes if an issue is detected. The cycle completes automatically in a few seconds.

## STEP 11 Set up your Remote.

**A** Slide the battery cover off and insert the provided AAA Batteries into the back of the Remote, then replace the battery cover.

**⚠ WARNING ⚠**  
Keep batteries away from children.

**B** The Remote should pair automatically. Test it by sitting on the seat and pressing any function button.

**If the Remote is not responding:** unplug the power cord from the outlet, then press and hold the "STOP" button on the Remote until the indicator lights on the battery side begin flashing. Keep the Remote close to the toilet, then plug the power cord back in. Pairing is complete when the indicator lights stop flashing.

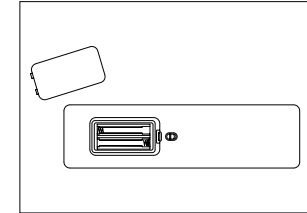

## STEP 12 Mounting Dock Installation (Optional)

**A** Use the Double-Sided Adhesive on tile or drywall. If mounting on drywall and you want a more permanent hold, use the included Mounting Screws instead.

**⚠ WARNING ⚠**  
Only install the Remote in a dry area.

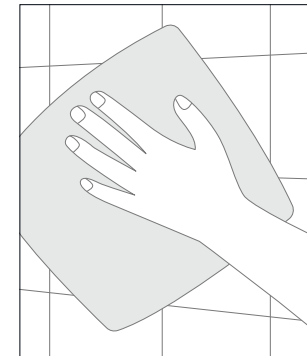

## STEP 12A Option 1: Adhesive Mount Installation

### DRYWALL AND TILE

- B** Clean the mounting area thoroughly and allow it to dry completely.
- C** Peel one side of the Double-Sided Adhesive backing and press it firmly to the center of the Mounting Dock.
- D** Peel the remaining backing and press the Mounting Dock firmly against the wall for 30 seconds.
- E** Wait at least 1 hour before placing the Remote in the dock.

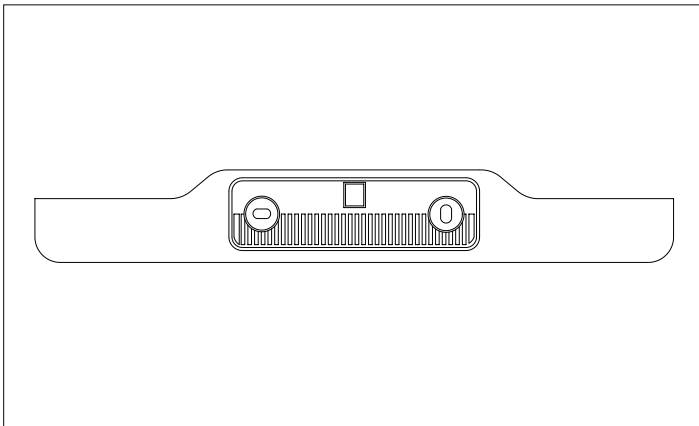

## STEP 12B Option 2: Screw Mount Installation

### DRYWALL AND TILE

- B** Mark two points on the wall 2.36" (60mm) apart, aligned with the bracket holes.
- C** Drill two ¼" (0.25") diameter holes at the marked points.
- D** Tap the included Plastic Anchors into the holes until flush with the wall surface – a hammer works well here.

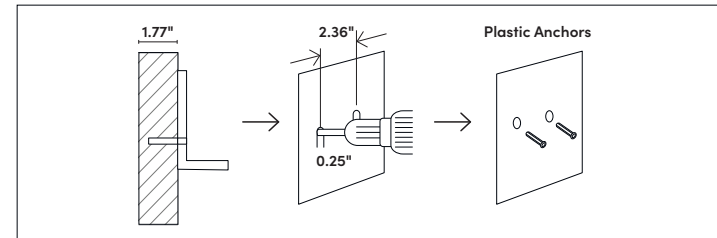

- E** Attach the Mounting Dock using the provided Mounting Screws and Washers. Use a level to confirm it's straight before fully tightening.
- F** Place the Remote in the dock to test the fit.

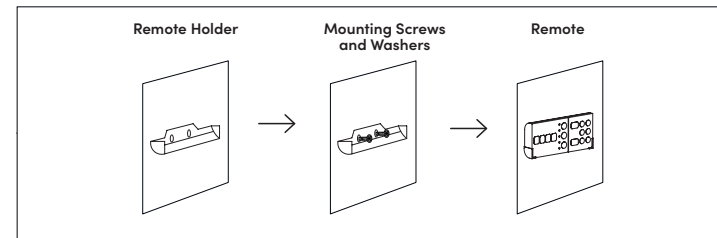

### TUSHY TIP

Can't decide on a mounting location? Set the dock aside and leave the Remote on the back of the toilet when not in use. You know your household—if kids or pets are in the mix, the Remote is likely to disappear if undocked.

### STEP 13 Apply caulk around the toilet.

After the toilet is installed, securely bolted down, and there have been no leaks from your connections and beneath the toilet for 24 hours, we recommend following your local plumbing code for applying caulk around the base of the toilet.

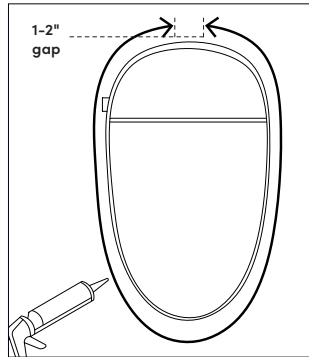

**A** Make sure you use a 100% silicone bathroom caulk that is mildew-resistant.

**B** Ensure the toilet is fully tightened and does not shift.

Wipe around the base of the toilet to make sure the area is clean and dry. Ensure there is no residue or debris.

**C** Apply a thin bead of silicone caulk along the front and sides of the toilet base.

**D** Smooth the bead with your finger or a damp cloth.

**6. IMPORTANT:** Leave a 1–2" gap in the caulk at the back of the toilet. This allows you to detect any future leaks before they cause damage.

**E** Allow the caulk to dry fully before use — typically 24 hours, or per the manufacturer's instructions.

## 6 Know Before You Go

### Spray responsibly.

Eau by TUSHY increases from a gentle spritz to a powerful wash. If you find that the water pressure is normally high, using the product at its top setting (especially for a long time) could cause irritation or other issues.

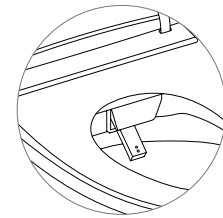

### External use only.

This product is only meant to wash the body parts you can see. As the water comes from your tap, it is not safe nor recommended to use as a douche or enema—doing so is dangerous and will likely cause bodily harm. For best butt health practices, talk to your doctor.

If you live in an area with unreliable electricity or frequent power outages, get the Battery Pack so you're never left stranded on the can. Find that at [hellotushy.com/parts](https://hellotushy.com/parts)

## Important Stuff

Read all instructions before installing or using the product. Failure to do so may result in injury or property damage. Always turn off the water supply valves before installing or performing maintenance on your TUSHY.

When using the product, adjust the pressure slowly. Increasing the pressure too fast may lead to discomfort or injury. If you're not sure about something, please consult a plumber or send us an email at [install@hellotushy.com](mailto:install@hellotushy.com).

Before using the product, make sure it is plugged into a 3-prong 120V GFCI outlet and your water valve is open. For you and your home's protection, this product will only function while you are sitting on the seat, which activates an internal sensor allowing for a refreshing wash.

Please review the quick start guide included in the product packaging. If you misplace it, scan the QR code below for a digital version.



Eau Remote Quick Start Guide

## 7 How to Use Eau by TUSHY

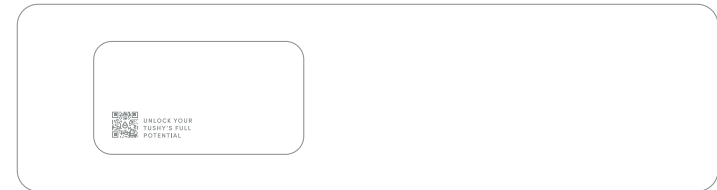
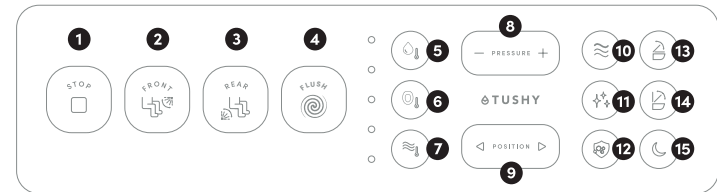

- |                     |                     |                    |
|---------------------|---------------------|--------------------|
| 1 Stop              | 7 Dryer Temperature | 13 Open/Close Lid  |
| 2 Front Wash        | 8 Water Pressure    | 14 Open/Close Seat |
| 3 Rear Wash         | 9 Nozzle Position   | 15 Night Light     |
| 4 Flush             | 10 Dryer            |                    |
| 5 Water Temperature | 11 Clean Nozzle     |                    |
| 6 Seat Temperature  | 12 Cloud Spray      |                    |

## Remote



### 1 Stop

Cancels any function when pressed.

**Special Function:** To pair the remote with the product, unplug the power cord and then press the Stop button on the remote until the remote lights start blinking. Plug in the power cord while the remote is near the seat. The lights should stop blinking. The remote is now paired with your product.



### 2 Front Wash

Cleans your front. Press again to move the nozzle back and forth during a wash to reach more areas and enjoy a gentle massage. Press it once for a short range, press it again for a longer range. Press again to return the nozzle to a fixed position. Each cycle will last 4 minutes, but you can stop earlier if you choose.



### 3 Rear Wash

Cleans your rear. Press again to move the nozzle back and forth during a wash to reach more areas and enjoy a gentle massage. Press it once for a short range, press it again for a longer range. Press again to return the nozzle to a fixed position. Each cycle will last 4 minutes, but you can stop earlier if you choose.

**Special Function:** Hold down Rear for 3s to enter Adjustable Halo Spray mode. When you activate this setting, the width of the spray will change between 3 different pressure settings. Hold for 3s to exit Adjustable Halo Spray mode. Press again to move the nozzle back and forth during a wash. Press it once for a short range, press it again for a longer range. Press again to return the nozzle to a fixed position.



### 4 Flush

Press to flush the toilet.



### 5 Water Temperature

Adjusts the water temperature across 6 different settings:

- Room Temp - OFF
- 88°F - 1 light showing
- 91°F - 2 lights showing
- 95°F - 3 lights showing
- 99°F - 4 lights showing
- 102°F - 5 lights showing

**Special Function:** Hold this button down for 5s to turn off/on any beeping sounds. The unit will beep twice when turned off and beep once when turned on.



### 6 Seat Temperature

Adjusts the seat temperature across 6 different settings:

- Room Temp - OFF
- 88°F - 1 light showing
- 91°F - 2 lights showing
- 95°F - 3 lights showing
- 99°F - 4 lights showing
- 102°F - 5 lights showing

**Special Function:** Hold for 5s to toggle Eco Mode. When active, the seat maintains your temperature setting only while in use, saving energy when idle. The side light turns blue in Eco Mode and red when off.



### 7 Dryer Temperature

Adjusts the air temperature across 6 different settings:

- Room Temp - OFF
- 95°F - 1 light showing
- 104°F - 2 lights showing
- 113°F - 3 lights showing
- 122°F - 4 lights showing
- 131°F - 5 lights showing

**Special Function:** Hold this button down for 5s to extend the nozzle allowing you to manually clean it. Press the Stop button to retract the nozzle.



### 8 Water Pressure

Adjusts the amount and speed of the water coming out of the nozzle. There are 5 settings.



### 9 Nozzle Position

Adjusts the nozzle's forward and backward position to find your ideal spray angle. There are 5 settings.



### 10 Dryer

Blows warm air to dry you after a wash. Press the dryer button again for more airflow. There are 3 airflow levels. Each cycle will last 4 minutes, but you can stop earlier if you choose.



### 11 Clean Nozzle

Runs an automatic nozzle self-cleaning cycle.

**Special Function:** Hold for 5s: Turns off/on automatic nozzle clean when sitting down. Default is on. The unit will beep twice when turned off and beep once when turned on.



### 12 Cloud Spray

Activates the Cloud Spray Auto Foaming Cleanser.

**Special Function:** Hold for 5s to toggle automatic Cloud Spray activation. The unit will beep once when turned on and twice when turned off.



### 13 Open/Close Lid

Opens/Closes the Lid. If the seat is up and you press the Lid button, both the lid and seat will close.

**Special Function:** Hold for 5s: Turns off Auto Open/Close for the Lid when the user is approaching the toilet. The unit will beep twice when turned off and beep once when turned on.



### 14 Open/Close Seat

Opens/Closes the Seat. If the lid is closed and you press the Seat button, both the lid and seat will open.

**Special Function:** Hold for 5s: Turns on the lid and seat both opening when the user approaches the toilet. The unit will beep twice when turned off and beep once when turned on.



### 15 Night Light

Turns on/off the internal light.

**Special Function:** Hold this button down for 5s to turn off/on the side light, Kick Button, and display. The unit will beep once when the light is turned on and beep twice when the light is turned off.

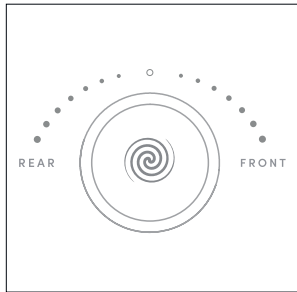

### Side Control Knob

- Turn knob forward to start Front Wash.
- Turn knob backward to start Rear Wash.
- While a wash is active, rotate knob forward to increase pressure, rotate knob backwards to decrease pressure.
- Press button to stop.
- Hold button down to turn off.

### UV Sterilization

The light around the button turns faint purple when UV sterilization is active. This occurs 10 seconds after each use and remains active for 3 minutes.

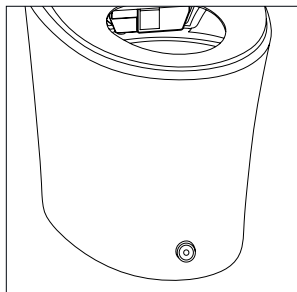

### Kick Button

- Lid and seat closed → one kick opens the lid; kick again to open the seat.
- Lid and seat open → one kick closes both and triggers a flush.

### Auto Deodorizer

This function will automatically turn on when sitting on the toilet, and will turn off 3 minutes after leaving the seat.

### Digital Display on Seat



Shows that the unit is on. When not displayed, the unit has been turned off.



If shown, the display is showing the selected water temperature.



If shown, the display is showing the selected seat temperature.



If shown, the display is showing the selected dryer temperature.



Displays the temperature of a certain function in Fahrenheit. Will also show possible errors that are occurring with the unit. For error codes, refer to the Troubleshooting section (p. 45).

## 8 Maintenance & Cleaning

### Maintenance of the Nozzle

Hold the Dryer Temperature button for 5 seconds without sitting on the seat; the nozzle will extend and can be cleaned with a soft brush. Do not try to pull the whole nozzle out with force or the nozzle may break. When you're done, press the Stop button to retract the nozzle.

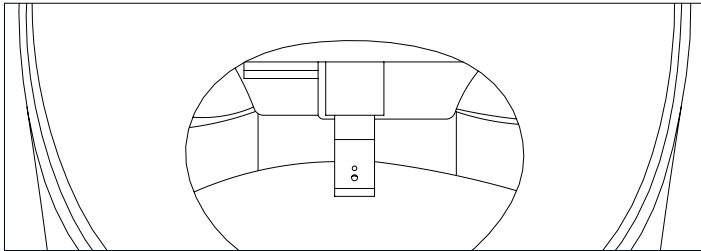

### Cleaning your Eau by TUSHY

To keep your product clean, wipe down the surfaces as frequently as you would a standard toilet using a mild, non-abrasive cleanser. When cleaning, apply the mild cleanser to a cloth first and avoid spraying directly onto the Eau display. You can use strong cleaning solutions on the ceramic portion of the product as you would a normal toilet.

**▲ CAUTION ▲** Avoid using harsh chemicals such as bleach or bleach-based products on your TUSHY's water hoses. These can cause the hose to crack and lead to leaks and water damage.

### Maintenance of Steel Mesh Filter

In order to ensure optimal performance, clean the steel mesh filter inside of your T-Adapter every 1-2 months.

- A** Turn off the water supply, perform a flush, unplug your smart toilet, and then disconnect the T-Adapter with Built-In Filter from the Bidet Hose and Flush Water Hose.
- B** Rinse the top and side connections of the T-Adapter with Built-In Filter under warm, running water to remove sediment.

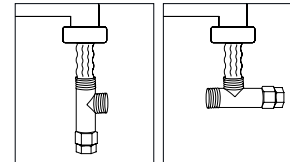

- C** Screw the T-Adapter With Built-In Filter back onto the hoses and turn on your water supply. Refer to page 20 for T-Adapter with Built-In Filter installation and follow subsequent steps.

### ANNUAL INSPECTION

We recommend conducting a yearly inspection of your toilet, adapter, and hoses to ensure their integrity and functionality. Check the adapter and hoses for any cracks, leaks, signs of rusting, rips, tears, or other damage. If you find any of these issues, discontinue use and contact us immediately.

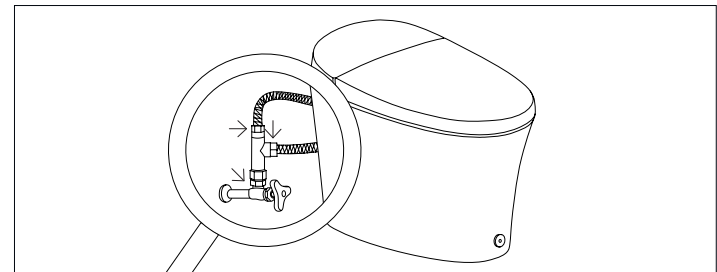

## 9 Warnings & Safety

### Read all instructions before installing or using your product.

Failure to do so could result in property damage, injury or death. Always turn off the water supply and disconnect all power sources before installing or performing maintenance on your Eau by TUSHY.

When tightening connections, make sure they are tight, but be careful not to overtighten, as this could result in leaks or property damage. Make sure you check for leaks after installing your product and periodically thereafter.

Do not attempt to open or perform internal maintenance on the product as this could result in injury or death as the device has electrical components.

### Important Safeguards

Keep children away during the installation process and exercise caution when using the device around children. To avoid the danger of suffocation, keep the plastic bags away from babies and children. Do not use this bag in cribs, beds, carriages, or playpens. This bag is not a toy.

**▲ DANGER ▲** To reduce the risk of electrocution:

- Connect the product to a properly grounded outlet only (refer to grounding instructions).
- Do not attempt to disassemble, modify, or alter the product.
- Do not pull the product by the power plug.
- Do not plug the product into an outlet that is being used by too many other products, is the incorrect voltage, or is loose.
- A damaged cord should be replaced or repaired immediately.
- Do not use a damaged power plug or plug into a loose electric outlet.
- Do not handle the product or power plug with wet hands.
- Do not handle the power plug forcefully or place heavy objects on the power plug.
- Remove any dust or water from the power plug before plugging in.

**▲ WARNING ▲** To reduce the risk of burns, electrocution, fire or injury:

- Use supervision when this product is used by, on, or near children or individuals with disabilities.
- For children and seniors who may have difficulties

with adjusting temperature or pressure or those with sensitive skin or impaired heat sensitivity, set the temperature and/or pressure of the wash spray and seat to “low” or “off” to prevent burning or injury.

- Use this product only for its intended use as described in this manual. Do not use attachments not recommended by the manufacturer.
- Never operate this product if it has a damaged cord or plug, if it is not working properly, has been dropped or damaged, or has been dipped into water. Contact customer support for diagnosis and repair.
- Keep the cord away from heated surfaces.
- Never drop or insert any object into any opening or hose.
- Do not use outdoors or operate where aerosol (spray) products are being used or where oxygen is being administered.
- Do not use industrial or gray water for the water supply (may cause skin damage or disease).
- Do not block air outlets.
- Do not place the product on soft surfaces where air openings may be blocked.
- Keep openings free of lint, hair, and other materials.
- Do not push buttons with excessive force or open the seat cover using excessive force.
- Do not place heavy objects on the seat cover.
- Do not use this product while sleeping or drowsy.

- Do not operate or use the product around flammable or combustible materials.
- Unplug and drain the product if it will not be used for a long period of time.
- Do not use thinner, benzene, acidic chemicals, chloride, or hydrochloric acid detergent to clean the product, because this could result in corrosion or discoloration/scratches to the product.
- Check all water supply connections regularly for leaks.
- Do not connect the product to the warm water supply during installation.

**▲ STANDING WARNING ▲** Do not stand on your Eau by TUSHY. Doing so could result in property damage, injury or death.

**▲ WATER HAMMER WARNING ▲** If you hear loud banging in your pipes during installation, stop immediately and consult a licensed plumber. Continuing may damage your plumbing and void your warranty.

**ACTION ON DAMAGE DETECTION:**

If you observe any signs of damage, rusting, leaks, rips, or tears in these components, turn off your water supply and disconnect the bidet immediately. Please contact us promptly at [warranty@hellotushy.com](mailto:warranty@hellotushy.com) to obtain replacement parts.

This device complies with part 15 of the FCC Rules. Operation is subject to the following two conditions: (1) This device may not cause harmful interference, and (2) this device must accept any interference received, including interference that may cause undesired operation. This equipment has been tested and found to comply with the limits for a Class B digital device, pursuant to part 15 of the FCC Rules. These limits are designed to provide reasonable protection against harmful interference in a residential installation. This equipment generates, uses and can radiate radio frequency energy and, if not installed and used in accordance with the instructions, may cause harmful interference to radio communications. However, there is no guarantee that interference will not occur in a particular installation. If this equipment does cause harmful interference to radio or television reception, which can be determined by turning the equipment off and on, the user is encouraged to try to correct the interference by one or more of the following measures: Reorient or relocate the receiving antenna. Increase the separation between the equipment and receiver. Connect the equipment into an outlet on a circuit different from that to which the receiver is connected.

## 10 Troubleshooting

### Installation

	PROBLEM	POSSIBLE CAUSES	POSSIBLE SOLUTIONS
1	<b>Water is leaking from the base of the toilet.</b>	<ol style="list-style-type: none"> <li>1. The Wax Ring was not properly installed.</li> <li>2. The toilet is not pressed down all the way.</li> <li>3. The Toilet Flange sits below the floor surface.</li> </ol>	<ol style="list-style-type: none"> <li>1. Realign the toilet with the Toilet Flange to make sure it's properly placed.</li> <li>2. Press down on the toilet to possibly create a better seal.</li> <li>3. Measure the height difference between the Toilet Flange and the floor ensuring it sits above the floor.</li> </ol>
2	<b>Water is leaking from the hose connections.</b>	<ol style="list-style-type: none"> <li>1. The black rubber gasket(s) are not properly installed on the hoses or adapters.</li> <li>2. The hose connection is cross-threaded.</li> </ol>	<ol style="list-style-type: none"> <li>1. Make sure that the black gasket(s) are properly installed on both ends of the product Hose and Flush Water Hose and the T-Adapter with Built-In Filter.</li> <li>2. Unscrew the hose and screw it back on making sure it is straight and aligned properly.</li> </ol>
3	<b>The T-Adapter with Built-In Filter isn't the same size as my angle valve.</b>	<ol style="list-style-type: none"> <li>1. We bet you have a unique plumbing setup.</li> </ol>	<ol style="list-style-type: none"> <li>1. Contact our Eau by TUSHY installation Poo-Rus at <a href="mailto:install@hellotushy.com">install@hellotushy.com</a> and we'll get you set up!</li> </ol>

## Usage

PROBLEM	POSSIBLE CAUSES	POSSIBLE SOLUTIONS
<b>1</b> <b>Display is showing E5-A: this means there is no water going to the product.</b>	<ol style="list-style-type: none"> <li>1. The water supply valve is still closed.</li> <li>2. The water lines may be kinked, limiting the water flow.</li> </ol>	<ol style="list-style-type: none"> <li>1. Open up your angle valve fully by turning it counter clockwise.</li> <li>2. Check the water lines to make sure the tubing is not kinked anywhere.</li> </ol>
<b>2</b> <b>My Eau by TUSHY buttons don't seem to work.</b>	<ol style="list-style-type: none"> <li>1. The product is not plugged in.</li> <li>2. No power flowing to Eau by TUSHY.</li> <li>3. There is power, but the remote's batteries are dead.</li> <li>4. Seat sensor not being activated properly.</li> </ol>	<ol style="list-style-type: none"> <li>1. Make sure the product is plugged in.</li> <li>2. Check and reset the GFCI outlet.</li> <li>3. Replace the batteries in the remote. Make sure the indicator lights are working.</li> <li>4. Adjust your sitting position to fully cover the Seat Sensor on the left front side of the seat when seated.</li> </ol>
<b>3</b> <b>Water pressure is weak.</b>	<ol style="list-style-type: none"> <li>1. The water pressure level is set to Low.</li> <li>2. T-Adapter with Built-In Filter is clogged.</li> <li>3. Nozzle is clogged.</li> </ol>	<ol style="list-style-type: none"> <li>1. Turn up the water pressure level on the remote by pressing the corresponding buttons. For more information, see the Quick Start Guide.</li> <li>2. Clean the steel mesh filter – go to page 39 for instructions.</li> <li>3. Clean the nozzle – go to the maintenance section on page 38 for instructions.</li> </ol>
<b>4</b> <b>The water is hot.</b>	<ol style="list-style-type: none"> <li>1. The temperature setting is too high.</li> <li>2. Eau by TUSHY may be connected to the warm water supply.</li> </ol>	<ol style="list-style-type: none"> <li>1. Adjust the temperature setting on the Remote by pressing the corresponding buttons. For more information, see the Quick Start Guide.</li> <li>2. Connect the Eau by TUSHY to the cold water supply.</li> </ol>

PROBLEM	POSSIBLE CAUSES	POSSIBLE SOLUTIONS
<b>5</b> <b>Eau by TUSHY shuts off during use!</b>	<ol style="list-style-type: none"> <li>1. Washing time exceeded the 4 min cycle.</li> <li>2. Power failure.</li> <li>3. Abnormal AC frequency into Eau by TUSHY.</li> </ol>	<ol style="list-style-type: none"> <li>1. Press the wash button again to extend the cycle time.</li> <li>2. Check and reset the GFCI outlet.</li> <li>3. If Eau display is showing Eau, your bidet has experienced an interruption in electrical frequency from the required 60HZ. A fault will be triggered when frequency is too low or too high. Please unplug the product and then plug back in to reset. If error code persists, please contact us at <a href="mailto:install@hellotushy.com">install@hellotushy.com</a> for help.</li> </ol>
<b>6</b> <b>Water is sputtering.</b>	<ol style="list-style-type: none"> <li>1. The water valve is not open all the way.</li> <li>2. The hose has a kink in it.</li> <li>3. T-Adapter with Built-In Filter may be clogged.</li> <li>4. Something is blocking your water line.</li> <li>5. Your home's water pressure is low.</li> <li>6. Sputtering at the highest pressure setting is normal due to the air-assisted spray system.</li> </ol>	<ol style="list-style-type: none"> <li>1. Check your valve and make sure it's fully open.</li> <li>2. Check all hoses for kinks. This can prevent water flow.</li> <li>3. Check and clean the filter in your T-Adapter, guidance on page 39.</li> <li>4. Undo each connection and check that no gasket is misplaced or blocking the water line.</li> <li>5. If your home has low water pressure, use lower pressure settings until you can address this with a plumber.</li> <li>6. If sputtering only occurs at the highest pressure setting, your unit is functioning normally. At maximum pressure, Eau by TUSHY uses an internal air pump to boost the spray pattern – this air injection is what causes the sputtering effect.</li> </ol>

PROBLEM	POSSIBLE CAUSES	POSSIBLE SOLUTIONS
7 Seat is not warm.	1. The seat temperature is set to "off". 2. Eco Mode is enabled. Eco Mode turns off the continuous seat heating and turns it back on when someone is on the seat to save energy.	1. Turn up the seat temperature to a higher setting on your remote. 2. Turn off Eco Mode. Hold the Seat Temp button for 5s to turn off Eco Mode. The remote will beep twice when Eco Mode is turned off.
8 Lid or Seat does not open automatically.	1. Lid and Seat Automatic Open/Close feature is turned off.	1. Turn the lid auto open back on. Hold the Lid button for 5s to turn on Lid and Seat Automatic Open/Close. The remote should beep when activated.
9 Cloud Spray is not working.	1. There is no more liquid in the reservoir. 2. Cloud Spray needs to work its way through the system.	1. Fill the reservoir with TUSHY Cloud Spray Auto-Foaming Cleanser. 2. Activate the Cloud Spray 3-5 times until the feature is performing as expected.
10 Can't flush the toilet.	1. The power is out.	1. If you live in an area prone to power outages, we recommend purchasing the compatible <b>Battery Pack</b> from our Spare Parts page to maintain functionality during outages. <a href="http://hellotushy.com/parts">hellotushy.com/parts</a>  <b>To flush during a power outage:</b> Slowly pour 1-2 gallons (4-8 liters) of water directly into the toilet bowl. Pour steadily to create a siphon effect and initiate a manual flush.

## 11 Limited Warranty

1. TUSHY warrants this product to be free from defects in materials and workmanship under conditions of normal use for a period of one (1) year from the date of purchase. This warranty is extended only to the original purchaser and is not transferable if the original purchaser sells or otherwise transfers the product. TUSHY may require proof of purchase to determine whether a claim falls within the warranty period.

2. To report any product issues and to open a claim under the warranty, contact TUSHY at [warranty@hellotushy.com](mailto:warranty@hellotushy.com). TUSHY will reach out to you to attempt to help resolve the issue.

3. If a defect covered by this warranty arises, TUSHY's obligations under this warranty are limited to repair or replacement, at TUSHY's option, provided that such products were used in accordance with the instructions. Replacement may be of the same or similar product at TUSHY's discretion and based on availability. TUSHY reserves the right to inspect the product to confirm that the issue is covered by this warranty.

4. TUSHY is not responsible for the cost of return shipping of this product.

5. This warranty does NOT apply to:

- Damage or loss that occurs during shipment.
- Damage, loss, or injury resulting from negligent or improper use or the user's failure to follow instructions and safety warnings.
- Damage or loss resulting from modification of the product.
- Damage or loss resulting from normal wear and tear of the product.
- Damage based on claims of personal injury or property damage, including, but not limited to, claimed damages that are incidental, or consequential in nature.

6. THIS WRITTEN WARRANTY IS THE ONLY WARRANTY MADE BY TUSHY. REPAIR OR REPLACEMENT AS PROVIDED UNDER THIS WARRANTY SHALL BE THE EXCLUSIVE REMEDY AVAILABLE TO THE PURCHASER. TUSHY SHALL NOT BE RESPONSIBLE FOR LOSS OF USE OF THE PRODUCT OR FOR OTHER INCIDENTAL, SPECIAL, OR CONSEQUENTIAL DAMAGES OR EXPENSES INCURRED BY THE PURCHASER OR A THIRD PARTY, OR FOR ANY OTHER EXPENSES NOT SPECIFICALLY STATED ABOVE. EXCEPT TO THE EXTENT PROHIBITED BY THE APPLICABLE LAW, ANY IMPLIED WARRANTIES, INCLUDING THOSE OF MERCHANTABILITY AND FITNESS FOR A PARTICULAR PURPOSE, ARE EXPRESSLY LIMITED TO THE DURATION OF THIS WARRANTY. SOME STATES DO NOT ALLOW LIMITATIONS, SO THE ABOVE LIMITATION AND EXCLUSION MAY NOT APPLY TO YOU.

7. This warranty gives you specific legal rights, and you may also have other rights which vary from state to state.

## 12 Contact Information

**We bend over backwards for your backside. Find a helpful bidet concierge every day at [hellotushy.com](https://hellotushy.com) — chat with a real pooping human!**

### Support Center

Self-service more your thing?  
Visit [hellotushy.com/support](https://hellotushy.com/support)

### Text Us

Keep us in your back pocket!  
Text MYTUSHY to 794-54 (US only) or  
+1 (888) 599-8926 (Canada only).  
Message us via WhatsApp at  
+1 (888) 218-8749.

### EMAIL US

#### Say Hi!

Comments! Compliments! Butt puns!  
[hello@hellotushy.com](mailto:hello@hellotushy.com)

#### Have General Qs?

i.e. shipping options, product availability:  
[questions@hellotushy.com](mailto:questions@hellotushy.com)

#### Need a Hook-up With the Hook-Up?

Install help, spare parts, and troubleshooting:  
[install@hellotushy.com](mailto:install@hellotushy.com)

@hellotushy   

**Bottoms up.  
You did this thing.**



Get ready to feel fresher than a spring breeze.

**HELLOTUSHY.COM**