



# Your Top to Bottom Manual



**TUSHY AURA**

Electric Bidet Seat



Derrière to dream bigger.

[HELLOTUSHY.COM](https://www.hellotushy.com)

# Congratulations!

You're about to experience luxury from the bottom up. This manual will guide you step by step through your TUSHY Aura installation. Get ready for a top tier toileting experience.

## **Online video resources:**

(for our visual learners)

<http://hellotushy.com/aura>



# Table of Contents

**4** Meet This Manual

---

**5** Meet Your TUSHY Aura

---

**8** Before You Start

---

**16** Install Your TUSHY Aura

---

**17** Prepare Your Toilet

---

**20** Connect Your TUSHY Aura

---

**34** Know Before You Go

---

**36** How To Use Your TUSHY Aura

---

**42** Maintenance & Cleaning

---

**45** Warnings & Safety

---

**50** Troubleshooting

---

**54** Warranty

---

**55** Contact Information

# 1 Meet This Manual

## Get into the groove

Let's get this POTTY STARTED! Turn on some rump-shakin' TUSHY Tunes. We've assembled the perfect tracks to get you in the mood to upgrade your toilet, your booty, and your life.



[hellotushy.com/tunes](https://hellotushy.com/tunes)

## Get comfy

Lay down a towel or the TUSHY box for some extra padding for your knees.

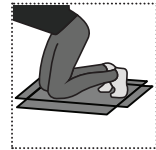

## Have a question?

Our Customer Experience Poo-Rus are ready to help. Email [install@hellotushy.com](mailto:install@hellotushy.com), chat with us on [hellotushy.com](https://hellotushy.com), text MYTUSHY to 794-54 (US only) or 1 (888) 599-8926 (Canada only), or message us via WhatsApp at 1 (888) 218-8749.

\*By signing up via text, you agree to receive recurring automated promotional, personalized marketing text messages (e.g. cart reminders), and bumperful puns from TUSHY at the cell number used when signing up. Consent is not a condition of any purchase. Reply HELP for help and STOP to cancel. Msg frequency varies. Msg & data rates may apply. View Terms (<https://hellotushy.com/pages/terms-of-use>) & Privacy (<https://hellotushy.com/pages/privacy-policy>)

## **2 Meet Your TUSHY Aura**

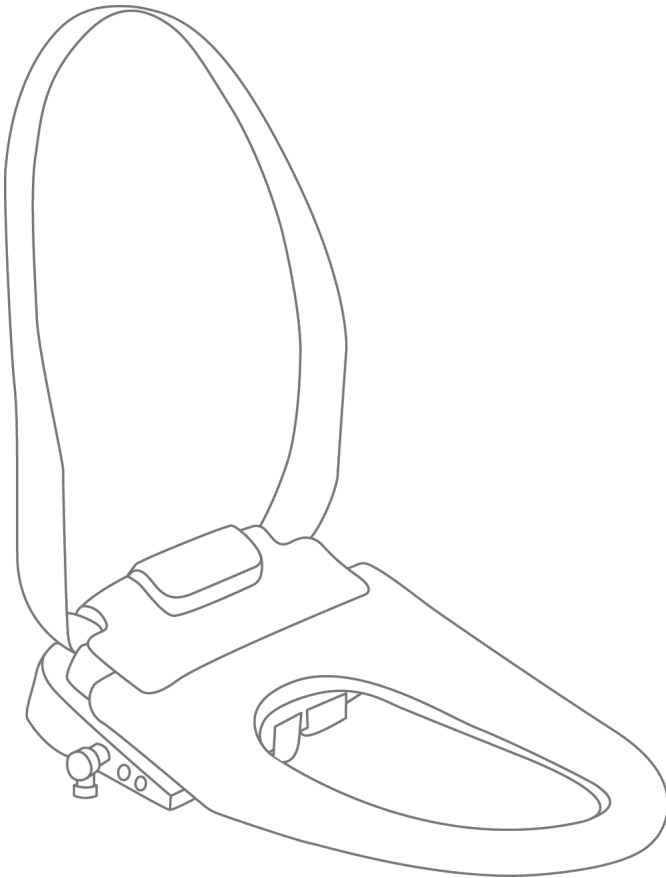

# Included Parts

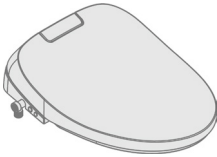

**TUSHY Aura**



**Remote**



**Mounting Dock**  
(includes Hardware Kit)



**Tank Adapter**  
( $\frac{7}{8}$  x  $\frac{3}{8}$  x  $\frac{1}{2}$ " Compression)

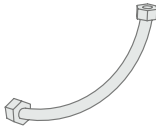

**Flexible TUSHY Hose**  
( $\frac{1}{2}$  x  $\frac{1}{2}$ " Compression)



**2x AAA Batteries**

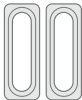

**2x Mounting Brackets**

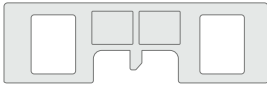

**Base Plate**

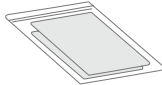

**Quick Start Guide**



**2x Bolt Washers**



**2x Mounting Bolts**



**2x Top-Mounting Rubber Inserts**

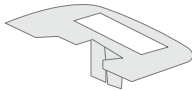

**Mounting Template**

## You'll Also Need:



**Flathead  
Screwdriver**

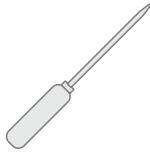

**Phillips Head  
Screwdriver**

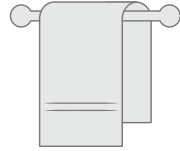

**Towels**  
(for any spills)

## Access to Power Outlet Within 3'

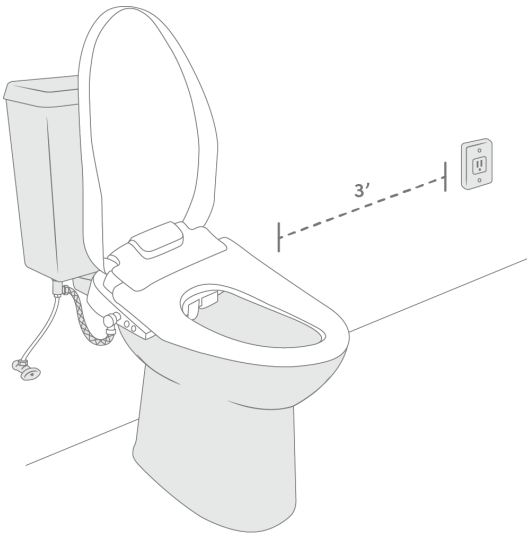

### **TUSHY TIP**

Keep all of these parts (and this manual) just in case you need them in the future!



Scan this code to watch our TUSHY Aura install video or go to [hellotushy.com/aura](https://hellotushy.com/aura)

## 3 Before You Start

### **Warnings and Safety:**

Read all instructions before installing or using your TUSHY Aura. Failure to do so could result in property damage, injury or death. Always turn off the water supply and disconnect all power sources before installing or performing maintenance on your TUSHY Aura.

When tightening connections, make sure they are finger tight, but be careful not to overtighten with any tools as this could result in leaks or property damage. Its OK to use a hand towel or rag to get a better finger grip. Make sure you check for leaks after installing your TUSHY Aura and periodically thereafter.

If you're not sure about something, please consult a plumber or send us an email at [install@hellotushy.com](mailto:install@hellotushy.com)





# Check Your Toilet

(There are different kinds of toilets? Who knew?)

## 1. Check you have the right seat for your bowl

### ROUND

A round bowl is typically shorter and rounder. It is commonly found on older toilets.

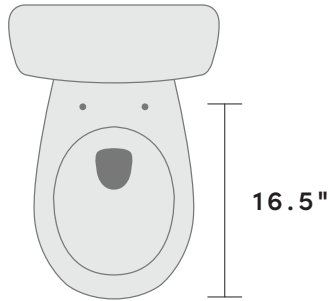

### ELONGATED

An elongated bowl is typically longer and more egg-shaped. It is commonly found on newer toilets.

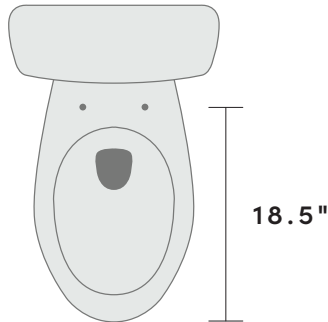

Make sure your TUSHY Aura matches your toilet's bowl shape. If they don't match or if you are unsure, reach out to [install@hellotushy.com](mailto:install@hellotushy.com) and we'll help you out.

## 2. Make sure you have the right parts for your toilet

### The Standard



**MOST  
COMMON**



**The Standard Toilet** is the most common toilet you'll find in the majority of residential homes. It typically has two pieces, consisting of the bowl and the tank, and has a flexible steel hose connection between the water supply and tank. Most importantly, all of the water supply connections are visible.

If you've got the Standard, you'll be good to go in no time!

---

If you have any questions at all, email [install@hellotushy.com](mailto:install@hellotushy.com) and we will be able to assist you.

## The Skirted



**Skirted Toilets** are a more modern, clean design that may hide the external tank connection. If you are able to access the tank connection, awesome! You shouldn't have too much trouble.

If you aren't able to access the tank connection, check out [hellotushy.com/skirtedtoilet](https://hellotushy.com/skirtedtoilet) for tips on how to connect these toilets with the valve adapter. We'll get you set up in no time.

---

If you have any questions at all, email [install@hellotushy.com](mailto:install@hellotushy.com) and we will be able to assist you.

## The Flushometer

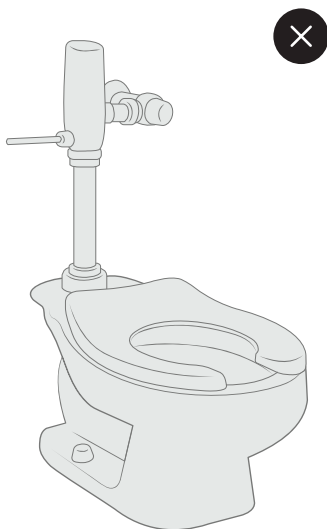

**The Flushometer Toilet** is normally found in commercial buildings, but some residential apartment buildings have these toilets too (looking at you, NYC friends). They have a lever with a powerful flush and no easy access to a water supply connection. At first glance, these toilets don't look TUSHY compatible, BUTT... we have a hack for that. ;)

If you have a flushometer toilet, check out [hellotushy.com/flushometer](https://hellotushy.com/flushometer) for guidance on how to connect these toilets relying on your sink with a valve adapter and longer hose.

---

If you have any questions at all, email [install@hellotushy.com](mailto:install@hellotushy.com) and we will be able to assist you.

## The French Curve

MAYBE



Do you oui oui in this type of potty? **French Curve Toilets** are one-piece toilets that are curved in the back. Though they are very high-end, they also tend to be hard to fit when it comes to any bidet seats or attachments.

To see if your toilet is compatible, check out [hellotushy.com/compatibility](https://hellotushy.com/compatibility).

---

If you have any questions at all, email [install@hellotushy.com](mailto:install@hellotushy.com) and we will be able to assist you.

### 3. Check your water connection

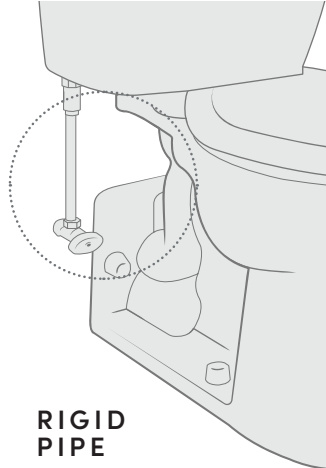
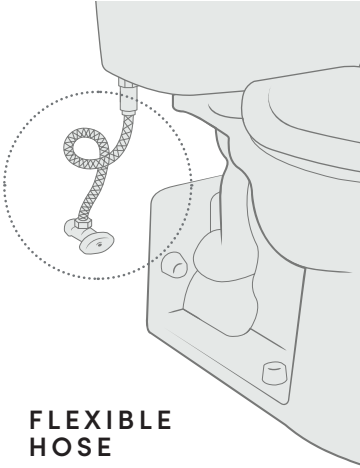

What kind of water connection does your toilet have? If you have a flexible hose (left), you're good to go.

If you have a rigid pipe, get the flexible pipe you'll need to replace it here: [hellotushy.com/flexhose](https://hellotushy.com/flexhose).

---

If you have any questions at all, email [install@hellotushy.com](mailto:install@hellotushy.com) and we will be able to assist you.

#### 4. Check your power outlet

**⚠ WARNING ⚠ Failure to read this may result in serious injury or death due to potential shock hazard. Before getting started, your TUSHY Aura must have access to a 3-prong 120V GFCI outlet to ensure safe operation.**

First, check the distance from the toilet to the outlet. If it is greater than 3 feet, you will need an extension cord. Ask our Poo-Rus for a recommendation, or grab any 3-prong extension cord you have handy.

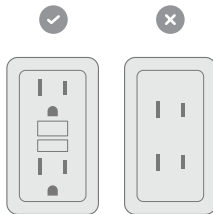

Next, check the outlet itself. If it looks like the one to the left, you are good to go! If it is a 2-prong outlet, you will need a grounded converter, so check with our Poo-Rus or your local hardware store for a recommendation.

**(Refer to page 45 for applicable warnings.)**

## 4 Install Your TUSHY Aura

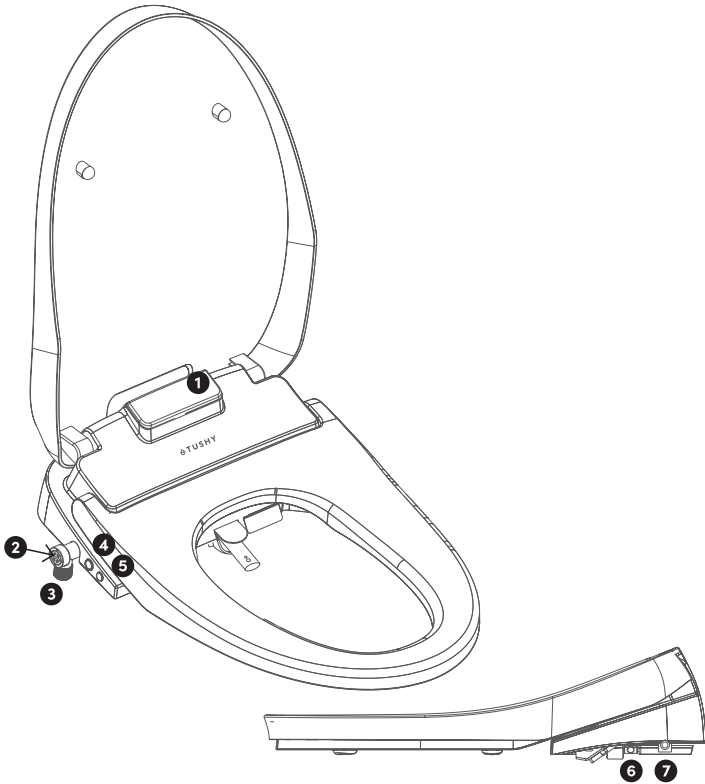

- |   |                   |   |                      |   |            |
|---|-------------------|---|----------------------|---|------------|
| 1 | Display Panel     | 4 | Power                | 7 | Power Cord |
| 2 | Steel Mesh Filter | 5 | Wash & Dry           |   |            |
| 3 | Water Inlet       | 6 | Quick Release Button |   |            |



## 5 Prepare Your Toilet

### STEP 1 Turn off your water supply valve

Turn off the water valve beside the toilet by turning it clockwise.

⚠ CAREFUL ⚠ Go slow and steady.

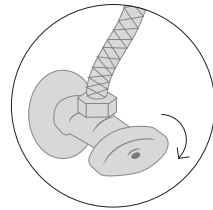

### TUSHY TIP

If the valve is tight, there may be some mineral buildup. In that case, try twisting in one direction and then the other, each time rotating a little further until it's free to turn all the way around. Slow and steady wins the race!

If you don't have access to the water supply connection beside the toilet, you can use your sink's water supply instead. For an installation video, go to [hellotushy.com/sinkconnect](https://hellotushy.com/sinkconnect).

### STEP 2 Empty the toilet tank

Flush your toilet to drain the tank. Hold down that flusher until the tank empties nearly completely! An inch of water at the bottom is okay, though.

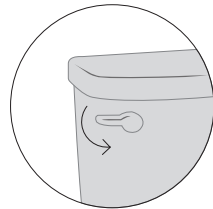

**STEP 3****Remove the toilet seat**

For most toilet seats, flip up the bolt caps behind the seat with a flathead screwdriver to access the bolts. Turn counterclockwise to loosen the bolts. Remove the seat and either store it (in case you ever need it) or bury it (in case you want to give your old seat a proper goodbye). Just kidding, recycle it!

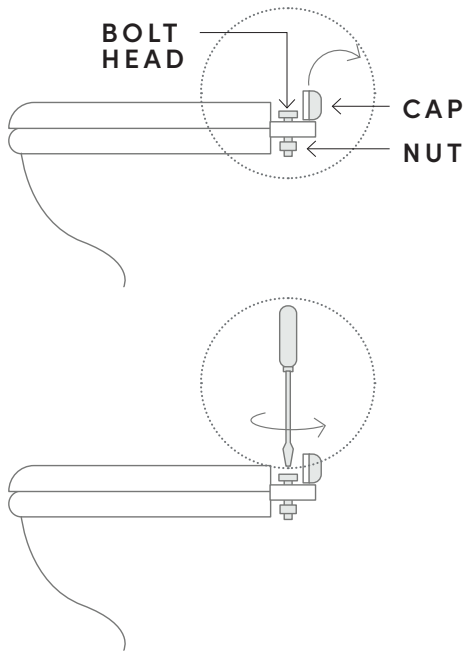
**TUSHY TIP**

You may need to hold the nut on the underside of the bolt with your other hand (using pliers or a towel if necessary) while unscrewing. If your toilet is dirty—hey, it happens!—it's the perfect time to clean it!

## Dealing with a unique quick-release or mounted toilet seat?



There's a super easy fix. Simply unscrew the bolts fastening the quick-release mounts to the toilet. Then you can remove them and store them with your seat if you ever need to reinstall it. The bolts may be under a plastic or metallic cover. Check out [hellotushy.com/mountedseatremoval](https://hellotushy.com/mountedseatremoval) for some video tips if you're having trouble.



Need help? We've got your backside.

Once you've got the seat off, set it aside and you're done!

## 6 Connect Your TUSHY Aura



**⚠ WARNING ⚠**

Connect to cold water line only—hot water  
can damage internal components

#### STEP 4

### Connect to the water line

**A Disconnect** the existing flexible hose from your toilet tank by turning it clockwise if you're looking at the connection from above. Be prepared to catch or wipe up some residual water that might spill onto the floor.

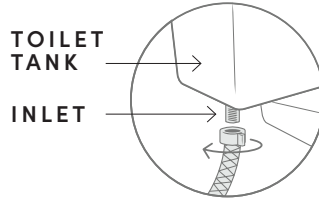

**B Screw** the existing flexible hose to the bottom of the Tank Adapter and then screw the top of the Tank Adapter counterclockwise onto the tank if you're looking from above. Make sure the black rubber gasket is inside the top of the adapter before screwing. Be careful not to overtighten!

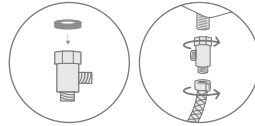

**C Screw** the provided Flexible TUSHY Aura Hose to the Tank Adapter's side connection. Check to see if there is a metal end of hose. Use the metal end of the hose to connect with the adapter. The other end will connect to the Aura. Be careful not to overtighten!

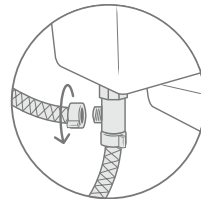

#### TUSHY TIP

If you don't have access to the toilet tank connection, you will need a valve adapter for installation at the shutoff valve at the wall or the sink instead. See how it's done and find the required adapter at [hellotushy.com/valveadapter](http://hellotushy.com/valveadapter). Got a hard metal pipe instead of a flexible hose connected to your toilet? No problem! Flip back to page 15 to learn how to swap that out and replace it with a flexible hose.

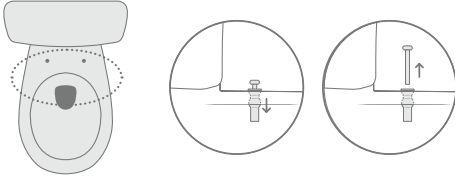
**STEP 5****Attach your TUSHY Aura Base Plate to the bowl**

**A** Insert the included Top-Mounting Rubber Inserts and Mounting Bolts into the toilet bolt holes until they are nearly flush with the surface. Keeping the Mounting Bolts inside the Rubber Inserts will provide a firm guide to push the rubber down into the holes. Once the rubber inserts are in place, unscrew the Mounting Bolts and set them aside along with the Washers until the end of Step 5.

**TUSHY TIP**

If you're having trouble getting the rubber inserts into the toilet bolt holes, use some soapy water to help them slide in easier!

**B** Place the Mounting Template on the toilet bowl where the mounting inserts are and make sure the Nozzle and Dryer tabs are folded down and are close to the rim and pointed down. This will show you where to place the Base Plate correctly so you don't have to keep tightening and loosening the mounting to find the right location.

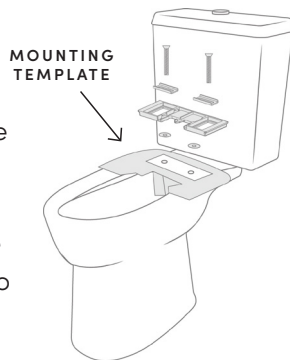

- Ⓒ Rest the Bolt Washer on top of the Rubber Inserts. Place the included plastic Base Plate over the toilet bolt holes, making sure it is centered and straight. Please also make sure the side of the Base Plate with rubber non-slip pads is facing down, not up. Line up the included Mounting Brackets on the Base Plate directly over the toilet bolt holes and in the opening of the Mounting Template.

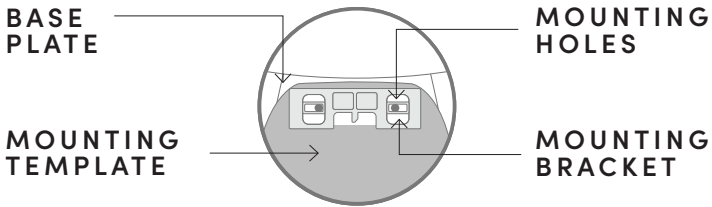

- Ⓓ Insert the Mounting Bolts through the top of the Mounting Brackets. Tighten them using a Phillips head screwdriver by turning clockwise until the Base Plate is snug, and doesn't wiggle. You can now remove the Mounting Template.

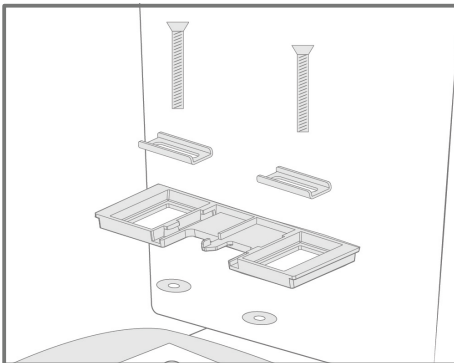

**STEP 6****Attach your TUSHY Aura  
to the Base Plate**

Next, place your TUSHY Aura onto your bowl in front of the Base Plate. You will notice that on the bottom of the main body there are two slots that will slide onto the Base Plate. Line those up with the Base Plate and slide towards the back of your toilet until it clicks into place and securely locks.

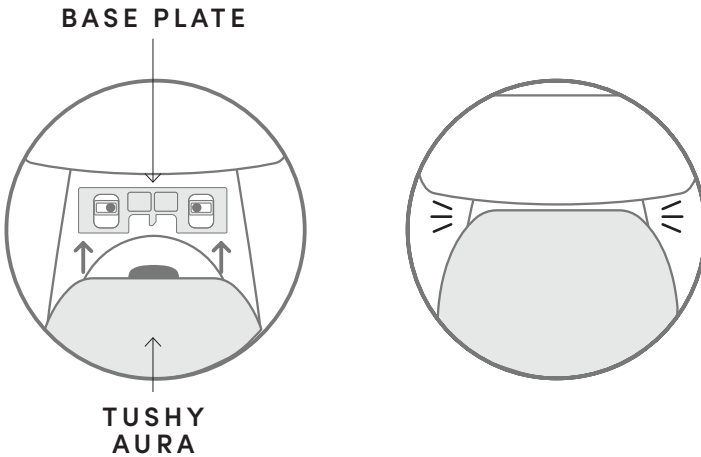



## Check your Aura alignment

### **A** No lip overhang or underhang

If you need to adjust the position of your TUSHY Aura, measure the amount of overlap at the front of your bowl so you can adjust the Base Plate accordingly.

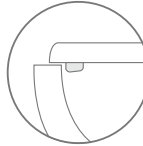
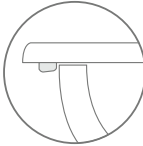
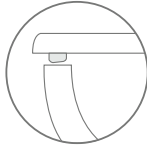
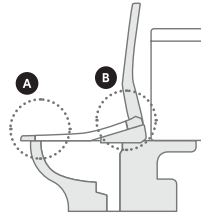

### **B** Sits flat on toilet bowl

Make sure your TUSHY Aura lies flat on your toilet bowl so the nozzle can function properly. Move it forward if the nozzle ramp is resting on the edge of the bowl.

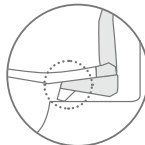
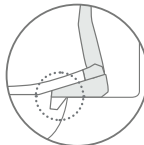

**C Centered on bowl**

Make sure your TUSHY Aura is straight on the toilet bowl.

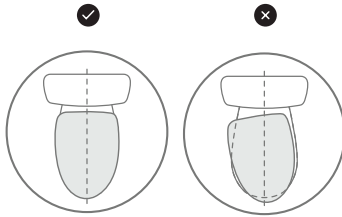

**D Enough space for lid**

Make sure there is enough space between the TUSHY Aura and your tank so the lid can open properly.

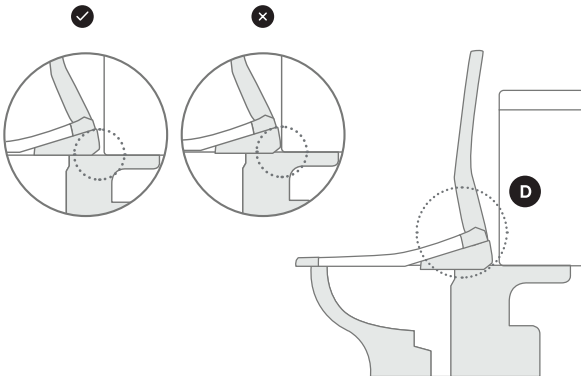

## TUSHY TIP

To remove TUSHY Aura from the Mounting Plate, press the Quick Release Button on the right side of the seat (when looking from above) and pull the seat away from the tank. Then, loosen the Mounting Bolts and adjust the Base Plate until it is in the desired location before reattaching your TUSHY Aura.

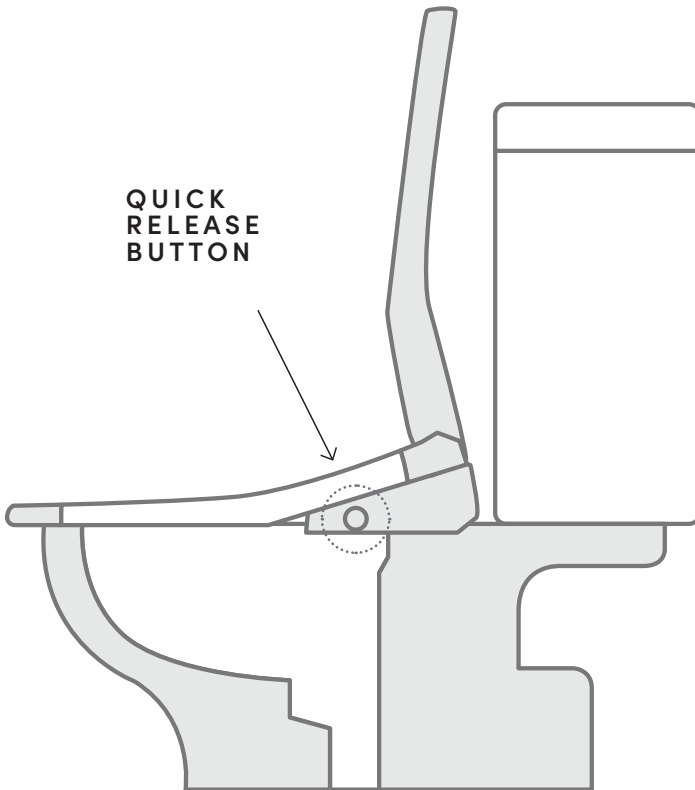

**STEP 7****Finish the water connection**

Take the open end of the Flexible TUSHY Aura Hose attached to the Tank Adapter and screw it onto the inlet port of the bidet in a clockwise direction when looking into the port connection. Do not overtighten—finger tight should be perfect.

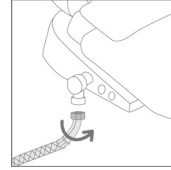
**STEP 8****Check for leaks**

**This is a super important step so that we can avoid any leaks. Nobody wants that.** Turn the main water valve on and off slowly one time to check the water connections for any leaks. Be sure to touch each hose to ensure water isn't running down them. Once there are no leaks, make sure your water valve is open, leave a towel or a bowl below the connections, and check back in an hour to ensure there are no slow leaks that may not be instantly visible.

If you are experiencing leaks, first make sure the black rubber gasket is placed correctly inside of the Tank Adapter. Second, ensure the threads are aligned properly. Third, make sure the hoses and adapters are tightened completely, but remember not to over tighten! If there is any water present after an hour, repeat the steps above. If not, you are good to go!

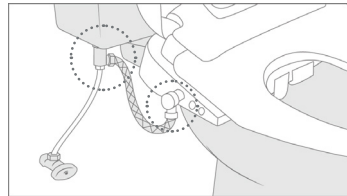

**STEP 9****Plug in your TUSHY Aura**

Once the connections are leak-free and the area around you is dry, plug your Aura into a 3-prong 120V GFCI outlet. Is your bum glowing yet?

**TUSHY TIP**

If your outlet is out of reach, go to [hellotushy.com/outlet](https://hellotushy.com/outlet) to get a 3-prong, grounded extension cord. While you wait, you can leave the TUSHY Aura on the toilet. It's still a functioning toilet seat! If you have a 2-prong outlet, purchase a grounding converter from a local hardware store or ask a Poo-Ru for recommendations. The grounding converter should be used only until a properly grounded outlet can be installed by a qualified electrician.

**Grounding Instruction**

**⚠️ DANGER ⚠️ Improper use of the grounding plug may result in a risk of electric shock. Refer to the Warnings and Safety page.**

This product has a 3-prong grounding plug, which must be plugged into an outlet that is properly installed and grounded. In the event of an electrical short circuit, grounding reduces the risk of electric shock by providing an escape wire for the electric current. If repair or replacement of the cord or plug is necessary, do not connect the grounding wire to either flat blade terminal. Check with a qualified electrician if you don't understand the grounding instructions, or if you're not sure whether the product is properly grounded. TUSHY Aura is intended for use on a nominal 120V 60 Hz circuit, and has a grounding plug that looks like the plug illustrated to the top right.



**STEP 10****Set up your Remote**

Slide the battery covers off and insert the provided AAA batteries into the back of the remote, then replace the battery covers.

**⚠ WARNING ⚠ Keep batteries away from children.**

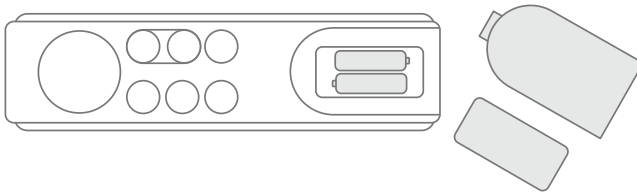

The remote should be automatically paired with the unit so give the product a test drive (you need to be sitting on the product). If the bidet seat is not responding, unplug the power cord, then hold down the “STOP” button on the remote until the indicator lights on the battery side of the remote start flashing. Make sure the remote is close to the bidet seat and plug the power cord back in. The indicator lights will stop flashing when the remote has successfully paired.

**STEP 11****Mounting Dock installation**

The future of toileting is here! Select an area of the wall that will be within reach of the toilet while seated.

The adhesive works best on drywall or tile. Only use the mounting screws on drywall.

**⚠ WARNING ⚠**

Only install the remote in a dry area.

**Adhesive Mounting Option (drywall and tile)**

For the adhesive, clean the area that works best and then make sure it is fully dry. Remove one side of the adhesive protection and attach it to the middle of the Mounting Dock. Make sure to press it firmly for 30 seconds. Afterwards, peel off the remaining side's protection and press it on your cleaned surface. Make sure to press it firmly against the wall for 30 seconds.

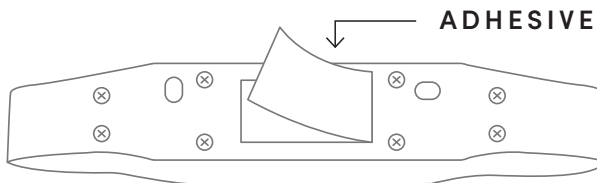

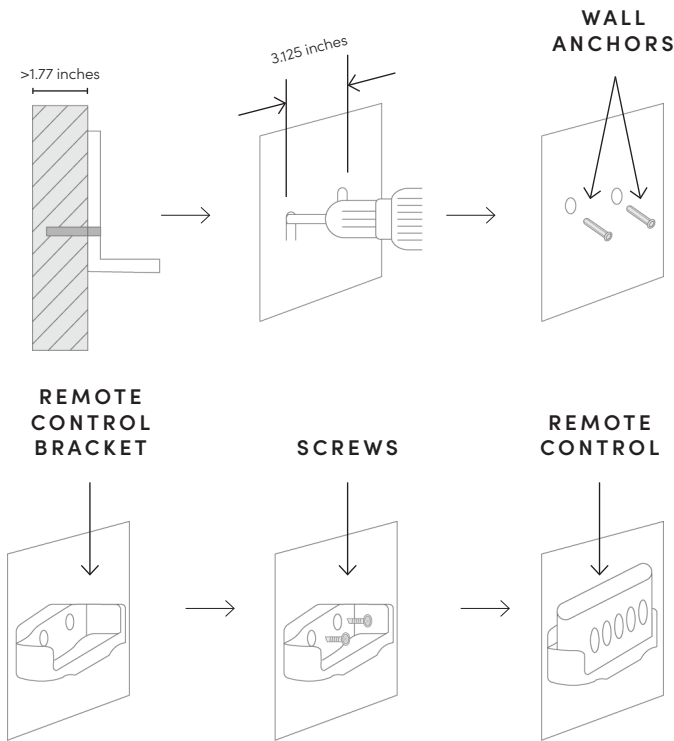

**Screw Mount Option (drywall only)**

For mounting screws (drywall only): drill two ¼" diameter holes on the wall 3.125" (45 mm) apart that align with the remote bracket. Install the wall anchors into the holes, you'll likely need a hammer to tap them into the hole until the ends are flush with the wall. Attach the Mounting Dock using the provided screws. Make sure the Mounting Dock is level. Go ahead and place your remote in the Mounting Dock for a test run.



## **TUSHY TIP**

Can't decide on a mounting location? Set the dock aside and leave the remote on the toilet tank when not in use. You know your household—if kids or pets are in the mix, the remote is likely to disappear if undocked.

**You did it. Call yourself a plumber, climb  
Mount Everest, clear your inbox, conquer it all.  
But first, enjoy your fancy new TUSHY.**



## 7 Know Before You Go

### **Spray responsibly.**

TUSHY Aura increases from a gentle spritz to a powerful wash. If you find the water pressure is normally high, using TUSHY at its top setting (especially for a long time) could cause irritation or other issues.

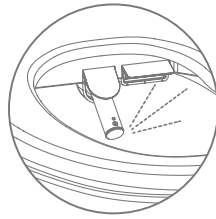

### **External use only.**

TUSHY is only meant to wash the body parts you can see. As the water comes from your tap, it is not safe nor recommended to use as a douche or enema—doing so is dangerous and will likely cause bodily harm. For best butt health practices, talk to your doctor.

## **Important Stuff**

Read all instructions before installing or using the TUSHY. Failure to do so could result in property damage. Always turn off the water supply valves before installing or performing maintenance on your TUSHY.

When using your TUSHY, adjust the pressure slowly. Increasing the pressure too fast may lead to discomfort or injury. If you're not sure about something, please consult a plumber or send us an email at [install@hellotushy.com](mailto:install@hellotushy.com).

Before using your TUSHY Aura, make sure it is plugged into a 3-prong 120V GFCI outlet and your water valve is open. For you and your home's protection TUSHY Aura will only function while you are sitting on the seat, which activates an internal sensor allowing for a refreshing wash.

Please review the quick start guide as well that was provided in the box. In case you lose it, scan the QR code on the remote shown here for your convenience.

# 8 How To Use Your TUSHY Aura

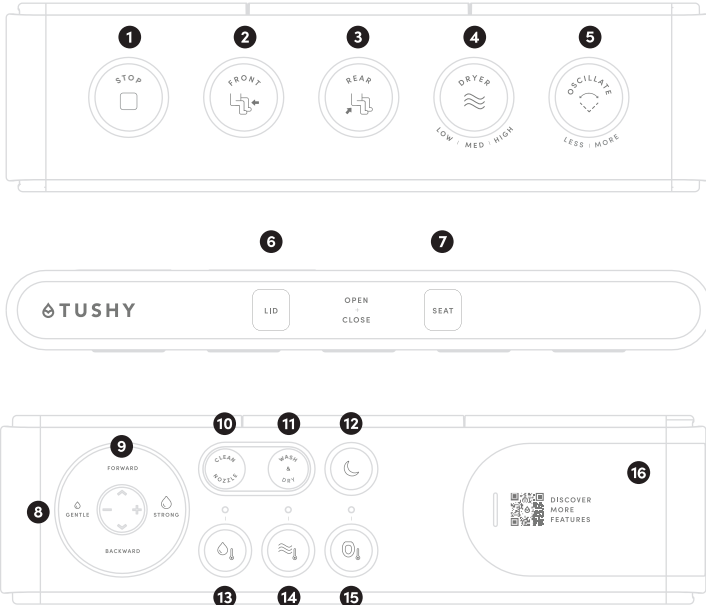

- |                      |                                  |                 |
|----------------------|----------------------------------|-----------------|
| 1 Stop               | 7 Seat Open/Seat Close           | 13 Water Temp   |
| 2 Front Wash         | 8 Water Pressure                 | 14 Dryer Temp   |
| 3 Rear Wash          | 9 Nozzle Forward/Nozzle Backward | 15 Seat Temp    |
| 4 Dryer              | 10 Clean Nozzle                  | 16 Battery Door |
| 5 Oscillate          | 11 Wash & Dry                    |                 |
| 6 Lid Open/Lid Close | 12 Night Light                   |                 |

## Front of Remote



### 1 Stop

Cancels any function if you press it.

**Special Function:** To pair the remote with the TUSHY Aura, unplug the power cord and then press the Stop button on the remote until the remote lights start blinking. Plug in the power cord while the remote is near the seat. The lights should stop blinking. The remote is now paired with the TUSHY Aura.



### 2 Front Wash

Cleans your front.



### 3 Rear Wash

Cleans your rear.



### 4 Dryer

Blows air to dry you after a wash. Press the dryer button again for more airflow. There are 3 levels.



### 5 Oscillate

Moves the nozzle back and forth during a wash to reach more areas and enjoy a gentle massage. Press it once for a short range, press it again for a longer range, press it a third time to return the nozzle to a fixed position.

## Top of Remote

LID

### 6 Lid

Opens/Closes the Lid. If the seat is up and you press the Lid button, both the lid and seat will close.

**Special Function:** Hold the Lid or Seat button for 5 seconds in order to turn off/on the Automatic Open/Close feature. The TUSHY Aura will beep twice when the feature is turned off and beep once when turned on.

SEAT

### 7 Seat

Opens/Closes the Seat. If the lid is closed and you press the Seat button, both the lid and seat will open.

**Special Function:** Hold the Lid or Seat button for 5 seconds in order to turn off/on the Automatic Open/Close feature. The TUSHY Aura will beep twice when the feature is turned off and beep once when turned on.

## Back of Remote



### 8 Water Pressure

Adjusts the amount and speed of the water coming out of the nozzle. There are 5 settings.



### 9 Nozzle Forward/Nozzle Backward

Adjusts the location of the spray. There are 5 settings.



### 10 Clean Nozzle

Goes through an automatic nozzle clean process.

**Special Function:** Hold this button down for 5 seconds to extend the nozzle allowing you to manually clean it. Press any button to return the nozzle back to the unit.



### 11 Wash & Dry

The unit will start a Rear Wash for 90 seconds and then automatically dry for 4 minutes. This feature is well-suited for kids and the elderly.



### 12 Night Light

Turns on/off the internal light.

**Special Function:** Hold this button down for 5 seconds to turn off/on the side light and display. The unit will beep once when the light is turned on and beep twice when the light is turned off.



### 13 Water Temperature

Adjusts the water temperature to 4 different settings:

- Room Temp - OFF
- 93°F - BLUE
- 99°F - PURPLE
- 102°F - RED

**Special Function:** Hold this button down for 5 seconds to turn off/on any beeping sounds. The unit will beep twice when turned off and beep once when turned on.



### 14 Dryer Temperature

Adjusts the air temperature to 4 different settings:

- Room Temp - OFF
- 95°F - BLUE
- 113°F - PURPLE
- 131°F - RED



## 15 Seat Temperature

Adjusts the seat temperature to 4 different settings:

- Room Temp - OFF
- 93°F - BLUE
- 99°F - PURPLE
- 102°F - RED

**Special Function:** You can hold this button for 5 seconds to implement Eco Mode where it saves your seat temperature setting but it doesn't keep your seat heated while you're not using the product to save on energy. The unit will beep once when you turn on Eco Mode and beep twice when you turn off Eco Mode. The side light will turn blue letting you know the product is in Eco Mode. When Eco Mode is off, the side light will be red.

### Side Panel on Seat

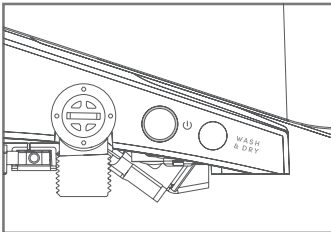

### UV Sterilization

The side light will turn a faint purple when the UV light is actively killing bacteria on the nozzle! This will occur automatically after a user gets up from the seat and will remain active for 3 minutes.

### Power

Stops any function when pressed. Hold the button to turn the unit off. Press the button to turn the unit on.

### Wash & Dry

The unit will start a Rear Wash for 90 seconds and then start the Dryer for 4 minutes. This feature is well suited for kids and the elderly.



## Digital Display on Seat



Shows that the unit is on. When not displayed, the unit has been turned off.



If shown, the display is showing the selected water temperature.



If shown, the display is showing the selected seat temperature.



If shown, the display is showing the selected dryer temperature.



Displays the temperature of a certain function in Fahrenheit. Will also show possible errors that are occurring with the unit. For those errors, please go to the Troubleshooting section.

## 9 Maintenance & Cleaning

Before any maintenance or cleaning, unplug the power cord and shut off the water supply. Regular maintenance is required to ensure that the product operates at optimum efficiency.

### Maintenance of Steel Mesh Filter

In order to ensure optimal performance, clean your internal filter every 1-2 months. The internal filter is located at the inlet valve where the Flexible Hose is attached. You will need a flathead screwdriver in order to take it out.

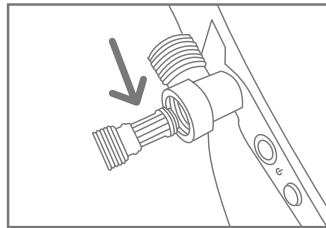
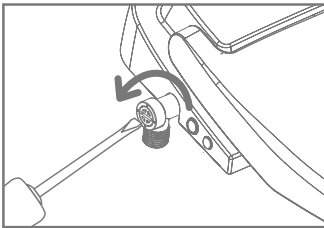

Unscrew the Steel Mesh Filter by turning counterclockwise with the screwdriver. Once the Steel Mesh Filter has been removed, you can run the filter under water or use a brush to clean out the openings in the steel mesh. After the Filter appears clean, insert it back into the housing and screw the filter by turning it clockwise until its hand tight. Check for leaks after opening the water supply valve.

Depending on your water hardness, we recommend replacing the water filter every 6 months to 1 year.

### **Maintenance of the Nozzle**

Hold the Nozzle Clean button for 5 seconds without sitting on the seat; the nozzle will extend and can be cleaned with a soft brush. Do not try to pull the whole nozzle out with force or the nozzle may break. When you're done you can press any button to retract the nozzle.

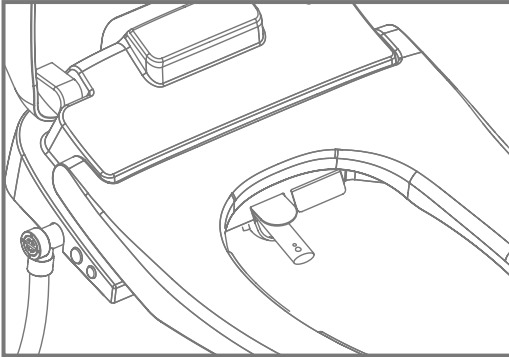

✧ ✧ ✧ **BIDET FUN FACT** ✧ ✧

The country with the most amore for the bidet? That's Italy. Since 1975, there has even been a legal requirement for every new bathroom to have one installed.

## **Cleaning your TUSHY Aura**

You should clean your TUSHY Aura as frequently as you clean your toilet with a mild cleanser that is non-abrasive. Use a mild cleaner to wipe down surfaces (avoid spraying directly onto your TUSHY). Do not use strong cleaning solutions such as alcohol, bleach, cresol, etc.

For a deeper clean, you can remove the TUSHY Aura from the toilet to access the surface beneath. To remove, press the Quick Release Button located on the right side of the product. While the button is pressed, pull the bidet towards you which will allow the product to freely move and you'll be able to clean the underside of the product and the toilet. Be careful as the water line is still attached!

**⚠ CAUTION ⚠** Avoid using harsh chemicals such as bleach or bleach-based products on your TUSHY's water hoses. These can cause the hose to crack and lead to leaks and water damage.

## **ANNUAL INSPECTION**

We recommend conducting a yearly inspection of your bidet, adapter, and hose to ensure their integrity and functionality. Check the adapter and hose for any cracks, leaks, signs of rusting, rips, tears, or other damage. If you find any of these issues, discontinue use and contact us immediately.

## 10 Warnings & Safety

**Read all instructions before installing or using your TUSHY Aura.** Failure to do so could result in property damage, injury or death. Always turn off the water supply and disconnect all power sources before installing or performing maintenance on your TUSHY Aura.

When tightening connections, make sure they are tight, but be careful not to overtighten, as this could result in leaks or property damage. Make sure you check for leaks after installing your TUSHY Aura and periodically thereafter.

**Do not attempt to open or perform internal maintenance on the TUSHY Aura as this could result in injury or death as the device has electrical components.**

### Important Safeguards

Keep children away during installation process and exercise caution when using the device around children. To avoid danger of suffocation, keep the plastic bags away from babies and children. Do not use this bag in cribs, beds, carriages, or playpens. This bag is not a toy.

### Read all instructions before using

- For 120V 60Hz: Power supply must be a 15 Amp GFCI outlet that is at least 1 foot above the floor.
- Avoid using extension cords if possible. If using an extension cord, make sure it is a 3-prong, grounded extension cord rated to 15 Amps.
- Install only in well-ventilated areas to avoid excess humidity.

- Do not install in narrow toilet stalls or in shower stalls.
- Install only where direct contact with water is minimized.
- Do not install near any heat source.

**⚠ DANGER ⚠ To reduce the risk of electrocution:**

- Do not place or store product where it can fall or be pulled into a tub or sink.
- Do not place or drop into water or other liquid.
- Do not reach for the product if it has fallen into water. Unplug immediately.
- Connect the product to a properly grounded outlet only (refer to grounding instructions).
- Do not attempt to disassemble, modify, or alter the product.
- Do not pull the product by the power plug.
- Do not plug the product into an outlet that is being used by too many other products, is the incorrect voltage, or is loose.
- A damaged cord should be replaced or repaired immediately.
- Do not use a damaged power plug or plug into a loose electric outlet.
- Do not handle the product or power plug with wet hands.
- Do not handle the power plug forcefully or place heavy objects on the power plug.
- Remove any dust or water from the power plug before plugging in.

**⚠ WARNING ⚠ To reduce the risk of burns, electrocution, fire or injury:**

- Use supervision when this product is used by, on, or near children or individuals with disabilities.
- For children and seniors who may have difficulties with adjusting temperature or pressure or those with sensitive skin or impaired heat sensitivity, set the temperature and/or pressure of the wash spray and seat to "low" or "off" to prevent burning or injury.
- Use this product only for its intended use as described in this manual. Do not use attachments not recommended by the manufacturer.
- Never operate this product if it has a damaged cord or plug, if it is not working properly, has been dropped or damaged, or has been dipped into water. Contact customer support for diagnosis and repair.
- Keep the cord away from heated surfaces.
- Never drop or insert any object into any opening or hose.
- Do not use outdoors or operate where aerosol (spray) products are being used or where oxygen is being administered.
- Do not use industrial or gray water for the water supply (may cause skin damage or disease).
- Do not block air outlets.
- Do not place the product on soft surfaces where air openings may be blocked.
- Keep openings free of lint, hair, and other materials.
- Do not push buttons with excessive force or open the seat cover using excessive force
- Do not place heavy objects on the seat cover.
- Do not use this product while sleeping or drowsy.
- Do not operate or use the product around flammable or combustible materials.
- Unplug and drain the product if it will not be used for a long period of time.

- Do not use thinner, benzene, acidic chemicals, chloride, or hydrochloric acid detergent to clean the product, because this could result in corrosion or discoloration/scratches to the product.
- Check all water supply connections regularly for leaks.
- Do not connect the product to the warm water supply during installation..

**⚠ WARNING ⚠ Do not stand on the TUSHY Aura.**  
**Doing so could result in property damage, injury or death.**

**⚠ WATER HAMMER WARNING ⚠** In the event that a loud banging noise occurs in the existing plumbing during installation, please cease using the device and consult a plumbing professional in order to prevent voiding your warranty and/or damaging your TUSHY Aura.

### **ACTION ON DAMAGE DETECTION**

If you observe any signs of damage, rusting, leaks, rips, or tears in these components, turn off your water supply and disconnect the bidet immediately. Please contact us promptly at [warranty@hellotushy.com](mailto:warranty@hellotushy.com) to obtain replacement parts.



This device complies with part 15 of the FCC Rules. Operation is subject to the following two conditions: (1) This device may not cause harmful interference, and (2) this device must accept any interference received, including interference that may cause undesired operation. This equipment has been tested and found to comply with the limits for a Class B digital device, pursuant to part 15 of the FCC Rules. These limits are designed to provide reasonable protection against harmful interference in a residential installation. This equipment generates, uses and can radiate radio frequency energy and, if not installed and used in accordance with the instructions, may cause harmful interference to radio communications. However, there is no guarantee that interference will not occur in a particular installation. If this equipment does cause harmful interference to radio or television reception, which can be determined by turning the equipment off and on, the user is encouraged to try to correct the interference by one or more of the following measures: Reorient or relocate the receiving antenna. Increase the separation between the equipment and receiver. Connect the equipment into an outlet on a circuit different from that to which the receiver is connected.



### **BIDET FUN FACT**



Did you know that bidets are not only superior to toilet paper, they're older too? TP was invented in the 1850's while the bidet first blessed our derrieres in the late 17th century.

# 11 Troubleshooting

## Installation

	Problem	Possible Causes	Possible Solutions
1	There is leaking from the TUSHY Aura body or hose connections.	<ol style="list-style-type: none"> <li>1. The black rubber gasket(s) are not properly installed on the hose or adapters.</li> <li>2. The hose connection is cross-threaded.</li> </ol>	<ol style="list-style-type: none"> <li>1. Make sure that the black gasket(s) are properly installed on both ends of the Flexible TUSHY Aura Hose and the Tank Adapter.</li> <li>2. Unscrew the hose and screw it back on making sure it is straight and aligned properly.</li> </ol>
2	The tank adapter isn't the same size as my toilet connection hose.	<ol style="list-style-type: none"> <li>1. We bet you have a unique plumbing setup.</li> </ol>	<ol style="list-style-type: none"> <li>1. Contact our TUSHY Aura installation Poo-Rus at <a href="mailto:install@hellotushy.com">install@hellotushy.com</a> and we'll get you set up!</li> </ol>
3	There's no access to water next to my toilet.	<ol style="list-style-type: none"> <li>1. You have a Flushometer or commercial toilet.</li> <li>2. You have a skirted toilet.</li> <li>3. You have a wall mounted toilet or a unique plumbing situation that doesn't allow you to connect at the water valve at the wall.</li> </ol>	<ol style="list-style-type: none"> <li>1. You can connect your TUSHY to your sink's water supply. If you want to start a Flushometer installation, visit our Flushometer page at <a href="http://hellotushy.com/flushometer">hellotushy.com/flushometer</a> for an instruction video and a parts kit you will need.</li> <li>2. Go to <a href="http://hellotushy.com/flushometer">hellotushy.com/flushometer</a> for tips on how to connect these toilets with a valve adapter.</li> <li>3. Contact our TUSHY Aura install Poo-Rus at <a href="mailto:install@hellotushy.com">install@hellotushy.com</a> and we'll get you set up!</li> </ol>

## Usage

	Problem	Possible Causes	Possible Solutions
1	Display is showing E5-A - this means there is no water going to the product.	<ol style="list-style-type: none"> <li>1. The water supply valve is still closed.</li> <li>2. The water lines may be kinked, limiting the water flow.</li> </ol>	<ol style="list-style-type: none"> <li>1. Open up your angle valve fully.</li> <li>2. Check the water lines to make sure the tubing is not kinked anywhere.</li> </ol>
2	My TUSHY Aura buttons don't seem to work.	<ol style="list-style-type: none"> <li>1. TUSHY Aura is not plugged in.</li> <li>2. No power flowing to TUSHY Aura.</li> <li>3. There is power, but the remote's batteries are dead.</li> <li>4. Seat sensor not being activated properly.</li> </ol>	<ol style="list-style-type: none"> <li>1. Make sure the TUSHY Aura is plugged in.</li> <li>2. Check and reset the GFCI outlet.</li> <li>3. Replace the batteries in the remote. Make sure the indicator lights are working.</li> <li>4. Adjust your sitting position to fully cover the Seat Sensor on the left side front side of the seat when seated.</li> </ol>
3	Water Pressure is weak.	<ol style="list-style-type: none"> <li>1. Water pressure level is set to Low.</li> <li>2. Steel Mesh Filter is clogged.</li> <li>3. Nozzle is clogged.</li> </ol>	<ol style="list-style-type: none"> <li>1. Turn up the water pressure level on the remote.</li> <li>2. Clean the steel mesh filter - go to the maintenance section for instructions.</li> <li>3. Clean the nozzle - go to the maintenance section for instructions.</li> </ol>
4	The water is too hot!	<ol style="list-style-type: none"> <li>1. The temperature setting is too high.</li> <li>2. TUSHY Aura may be connected to the warm water supply.</li> </ol>	<ol style="list-style-type: none"> <li>1. Adjust the temperature setting on the remote.</li> <li>2. Connect the TUSHY Aura to the cold water supply.</li> </ol>



Scan for more troubleshooting support and video tutorials.

	Problem	Possible Causes	Possible Solutions
5	TUSHY Aura shuts off during use!	<ol style="list-style-type: none"> <li>1. Washing time exceeded the cycle time.</li> <li>2. Power failure.</li> <li>3. Abnormal AC frequency into Bidet.</li> </ol>	<ol style="list-style-type: none"> <li>1. Press the wash button again to extend the cycle time.</li> <li>2. Check and reset the GFCI outlet.</li> <li>3. If Aura display is showing E1-A, your bidet has experienced an interruption in electrical frequency from the required 60HZ. A fault will be triggered when frequency is too low or too high. Please unplug the bidet and then plug back in to reset. If error code persists, please contact TUSHY for help.</li> </ol>
6	Water is sputtering.	<ol style="list-style-type: none"> <li>1. Water valve is not open all the way.</li> <li>2. Hose has a kink in it.</li> <li>3. Steel mesh filter may be clogged.</li> <li>4. Something is blocking your water line.</li> <li>5. Your water pressure is too low.</li> </ol>	<ol style="list-style-type: none"> <li>1. Check your valve and make sure its open all the way.</li> <li>2. Check your water line ensuring no hose is kinked preventing water flow.</li> <li>3. Remove filter to clean. See the maintenance section for instructions. If filter is too clogged and cannot be fully cleaned, replace it with a new filter at <a href="http://hellotushy.com/aurafilter">http://hellotushy.com/aurafilter</a>.</li> <li>4. Undo each connection and see if any gasket is misplaced potentially blocking the water line</li> <li>5. If your home has low water pressure, you're probably experiencing some sputtering at the higher pressures. We recommend using low water pressure settings until you can call a plumber to address this issue.</li> </ol>

	Problem	Possible Causes	Possible Solutions
7	Seat is not warm.	<ol style="list-style-type: none"> <li>1. Seat temperature is set to off.</li> <li>2. Eco Mode is enabled. Eco Mode turns off the continuous seat heating and turns it back on when someone is on the seat to save energy.</li> </ol>	<ol style="list-style-type: none"> <li>1. Turn up the seat temperature to a higher setting on your remote.</li> <li>2. Turn off Eco Mode. Hold the Seat Temp button for 5 seconds to turn off Eco Mode. The remote will beep twice when Eco Mode is turned off. .</li> </ol>
8	Lid or Seat do not open automatically.	<ol style="list-style-type: none"> <li>1. Lid and Seat Automatic Open/Close feature is turned off.</li> </ol>	<ol style="list-style-type: none"> <li>1. Turn lid auto open back on. Hold the Lid or Seat button for 5 seconds to turn on Lid and Seat Automatic Open/Close. The remote should beep when activated.</li> </ol>

## Display Error Codes

During usage, your Aura display may show a diagnostic error code, which may impact functionality. An error code will start with the letter E followed by a number and then a letter (Ex. E5-A).

You'll find error codes listed in Troubleshooting based on the issue.

If you see any other error code that is not detailed in the Troubleshooting guide, turn off the bidet and unplug it. Plug the bidet back in to reset. If the error code persists, please contact TUSHY for help.

# 12 One Year Limited Warranty

1. TUSHY warrants this product to be free from defects in materials and workmanship under conditions of normal use for a period of one (1) year from the date of purchase. This warranty is extended only to the original purchaser and is not transferable if the original purchaser sells or otherwise transfers the product. TUSHY may require proof of purchase to determine whether a claim falls within the warranty period.

2. To report any product issues and to open a claim under the warranty, contact TUSHY at [warranty@hellotushy.com](mailto:warranty@hellotushy.com). TUSHY will reach out to you to attempt to help resolve the issue.

3. If a defect covered by this warranty arises, TUSHY's obligations under this warranty are limited to repair or replacement, at TUSHY's option, provided that such products were used in accordance with the instructions. Replacement may be of the same or similar product at TUSHY's discretion and based on availability. TUSHY reserves the right to inspect the product to confirm that the issue is covered by this warranty.

4. TUSHY is not responsible for the cost of return shipping of this product.

5. This warranty does NOT apply to: Damage or loss that occurs during shipment. Damage, loss, or injury resulting from negligent or improper use or the user's failure to follow instructions and safety warnings. Damage or loss resulting from modification of the product. Damage or loss resulting from normal "wear and tear" of the product. Damage based on claims of personal injury or property damage, including, but not limited to, claimed damages that are incidental, or consequential in nature.

6. THIS WRITTEN WARRANTY IS THE ONLY WARRANTY MADE BY TUSHY. REPAIR OR REPLACEMENT AS PROVIDED UNDER THIS WARRANTY SHALL BE THE EXCLUSIVE REMEDY AVAILABLE TO THE 40 41 PURCHASER. TUSHY SHALL NOT BE RESPONSIBLE FOR LOSS OF USE OF THE PRODUCT OR FOR OTHER INCIDENTAL, SPECIAL, OR CONSEQUENTIAL DAMAGES OR EXPENSES INCURRED BY THE PURCHASER OR A THIRD PARTY, OR FOR ANY OTHER EXPENSES NOT SPECIFICALLY STATED ABOVE. EXCEPT TO THE EXTENT PROHIBITED BY THE APPLICABLE LAW, ANY IMPLIED WARRANTIES, INCLUDING THOSE OF MERCHANTABILITY AND FITNESS FOR A PARTICULAR PURPOSE, ARE EXPRESSLY LIMITED TO THE DURATION OF THIS WARRANTY. SOME STATES DO NOT ALLOW LIMITATIONS, SO THE ABOVE LIMITATION AND EXCLUSION MAY NOT APPLY TO YOU.

7. This warranty gives you specific legal rights, and you may also have other rights which vary from state to state.

# 13 Meet the TUSHY Poo-Rus

We bend over backwards for your backside. Find a helpful bidet concierge every day at [hellotushy.com](https://hellotushy.com) — chat with a real pooping human!

## Support Center

Self-service more your thing?  
Visit [hellotushy.com/support](https://hellotushy.com/support)

## Text Us

Keep us in your back pocket!  
Text MYTUSHY to 794-54 (US only)  
or 1(888) 599-8926 (Canada only).  
Message us via WhatsApp at  
1(888)218-8749

## EMAIL US

### Say Hi!

Comments! Compliments! Butt puns!  
[hello@hellotushy.com](mailto:hello@hellotushy.com)

### Have General Qs?

i.e. shipping options, product availability:  
[questions@hellotushy.com](mailto:questions@hellotushy.com)

### Need a Hook-up With the Hook-Up?

Install help, spare parts, and troubleshooting:  
[install@hellotushy.com](mailto:install@hellotushy.com)

## Subscriptions

Change address, change frequency, or cancel by logging in at [hellotushy.com](https://hellotushy.com)

## Returns

Send it back?! OK, I guess.  
[hellotushy.com/returns](https://hellotushy.com/returns)

@hellotushy   

**Bottom's up.  
You did this thing.**



The (rear) end.