

## Introduction

Thanks for purchasing an MK Machining MK2.5 Bullpup Chassis. With installation of this chassis you will completely transform your rifle, reduce overall length of your firearm, add modularity and adjustability, enhance balance when shooting in unsupported positions, and upgrade your trigger as well. For other Remington 700 footprint actions, there may be minor differences, we have tested several custom actions with success thusfar.

All pieces of the chassis are precisely machined to tight tolerances. If something isn't fitting right, particularly with the linkage, don't force it. We are more than happy to answer any questions, and we'd rather help a customer with any installation difficulties than have parts be damaged.

**Before doing anything, MAKE SURE YOUR RIFLE IS UNLOADED.**

Proceed to Section 2 and make sure all parts listed in the table are included. There are labeled drawings to make identification of parts easier. Read Section 3 to ensure you are confident installing your barreled action into the chassis and hooking up the linkage system, then proceed through Section 3 to convert your Remington 700 into a bullpup rifle!

Are you a better visual learner? Video instructions will be available at [mkmachining.com](http://mkmachining.com) under the support section.



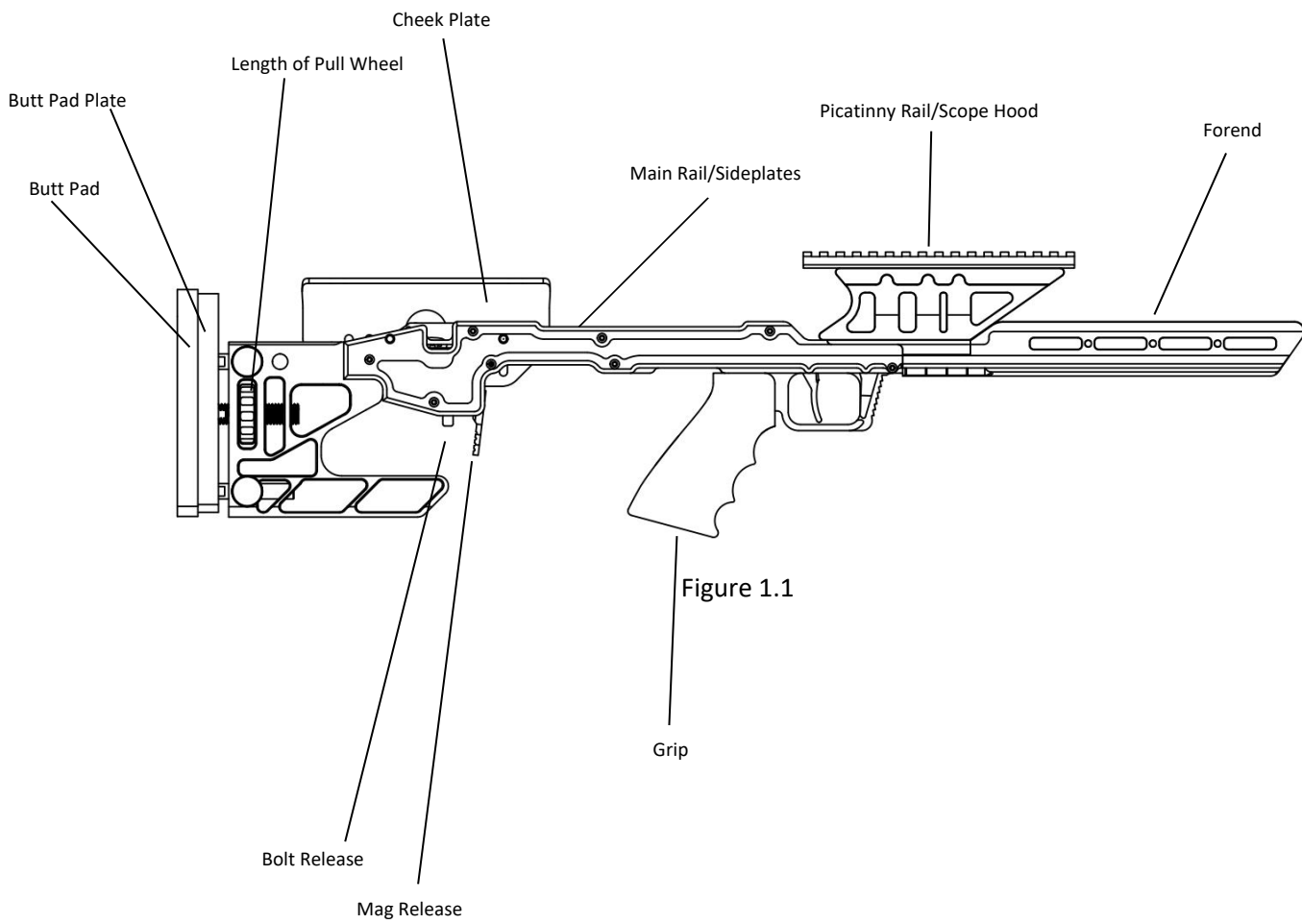

## **3 – Assembling Bullpup Chassis**

Described below is a step by step description of how to disassemble a bare-stock Remington 700 with no optics or mounting hardware, and install it in the MK Machining Bullpup Chassis correctly. The directions listed below need to be followed in order to ensure that the rifle operates as it was designed to. Before beginning this process, it is best to find a bench or flat area to lay the bullpup flat as well as your current rifle.

To complete the installation, you will need the following tools:

SAE/ standard set of allen wrenches  
Torque Wrench  
1/8" diameter punch  
Small to medium hammer

Remember To Ensure That Your  
Fire Arm Is Unloaded At Every  
Step!

Feeling Unsure About Assembly?  
Contact Your Regular Gunsmith  
Or Contact US At  
[support@mkmachining.com](mailto:support@mkmachining.com) For  
Assistance

### 3.1 - Disassembling Current Rifle

In order to install the barrel and action into the bullpup chassis you first need to remove it from its current stock. Before going any further it is important to remove the bolt from the action and set to the side. **Remove any cartridges that may still be in chamber or located in magazine before proceeding.** To remove the barrel and action you will need to remove two socket head cap screws located on the bottom side of the stock as shown in figure 3.1.1. Once the two bolts are removed, carefully lift the action/barrel assembly upward and out of the stock. After removing the barreled action, place it flat in front of you and place the original stock to the side.

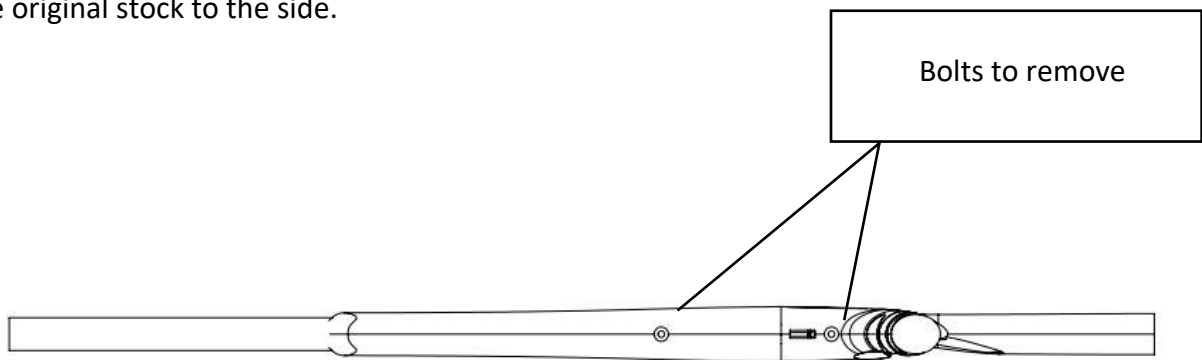

Figure 3.1.1 – Socket head cap screws to remove

Feeling Unsure About Assembly? Contact  
Your Regular Gunsmith Or Contact US At  
[support@mkmachining.com](mailto:support@mkmachining.com) For Assistance

### 3.2 - Disassembling Stock Trigger

Now that you have removed the action/barrel assembly, it is time to remove the stock trigger from the action. The MK Machining Bullpup comes with a custom Timney Calvin Elite that will allow the bullpup linkages to work with the action and produce a phenomenal bullpup trigger feel. Begin by grabbing a punch and hammer to remove the pins shown in figure 3.2.1. Once the pins are removed, carefully pull the trigger downward to remove it from the action. Place the trigger and the barreled action aside. When removing the trigger making sure to pay special attention the bolt release. Some bolt releases utilize a spring that is easy to lose.

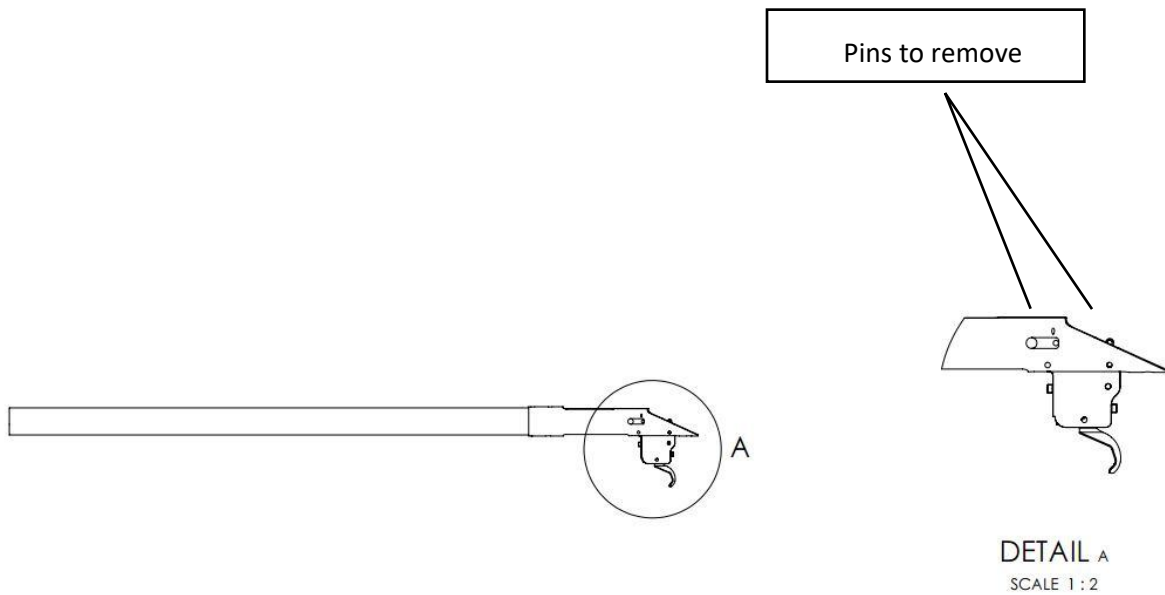

Figure 3.2.1 – Trigger pins to remove

Feeling Unsure About Assembly? Contact  
Your Regular Gunsmith Or Contact US At  
[support@mkmachining.com](mailto:support@mkmachining.com) For Assistance

### 3.3 – Installing New Trigger

Once work area is clear, remove the custom Timney Calvin elite trigger from its package. Install the new trigger by aligning the holes in the trigger with the holes in the action, then tapping the pins through both the trigger and action. The assembly should look the same as figure 3.3.1.

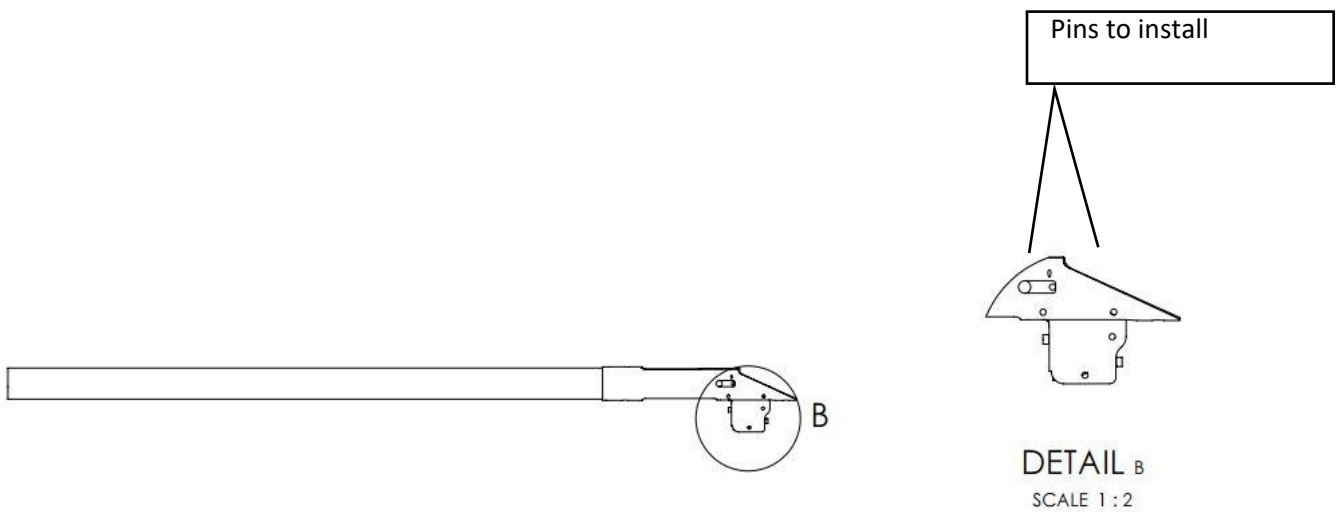

Figure 3.3.1

### 3.4 – Preparing Bullpup Chassis for Installation

Now that you have assembled the new trigger to the action, it is time to install the action in the bullpup chassis. To do this, first we have to remove the cheek piece and side panels. Next you will need to remove the scope hood. All other components will be already removed from the main rail and stored separately in the box.

### 3.5- Installing & Hooking Up Barreled Action

Once the the side panels are removed you can access the operating rod assembly, or op rods for short. Treat these components with care, they are not delicate, but bending an op rod, or damaging a linkage component will ruin trigger feel.

Bolt your barreled action with the new Calvin Elite into your main rail with approximately 30 in/lbs of torque. Be sure to insert the Rear Action Shim between the rear tang of your action and the rear action bolt hole on the main rail. Thread locker not above medium strength is recommended if you do not plan on disassembling your rifle in the near future.

Install the safety connecting block first, you want to slide the safety into the "safe" position with the levers back into the trigger guard, and loosen the safety operating rod via the screw at the front of the main rail to allow further travel of the safety operating rod. The small shaft of the safety connecting block will then fit into the pocket on the safety plate. Now slide the safety op rod back into the connecting block. Tighten screws down securely with a 1/16" allen wrench (we recommend high quality, such as Bondhus) so when your trigger is on "fire" the safety levers are flush with the trigger guard. Pulling the levers rearward will engage the safety.

Next install the trigger arms. First, you will need to loosen the screw on the front trigger connecting block. Next slide the op rod forward, and slide the trigger arm over the post in the trigger and the top portion of the trigger arm over the op rod. The trigger arm itself to be flush with the pivot pin. **Position the trigger arm to be perfectly vertical (see the photo below for correct positioning). Once the trigger arm has been aligned tighten down both bolts in the rear and the one the front that you loosened. Tighten screws down securely but do not over tighten. Over tightening can lead to binding on op rods, which can lead to poor trigger feel. Next complete the same trigger arm installation on the left side. Left and right sides will be mirror images, minus the safety plate on the left side. It is important for the left and right side to be positioned in the same way. Next make sure that your firearm is unloaded and check trigger and safety functionality. It is extremely important to test safety functionality. If the right trigger arm is not positioned correctly it can interfere with safety functionality.**

A **LOW** strength thread locker is recommended. Do **NOT** use higher strength, you will have trouble removing the adjustment screws.

Your linkage setup should look very similar to the below pictures

Rear Right Side

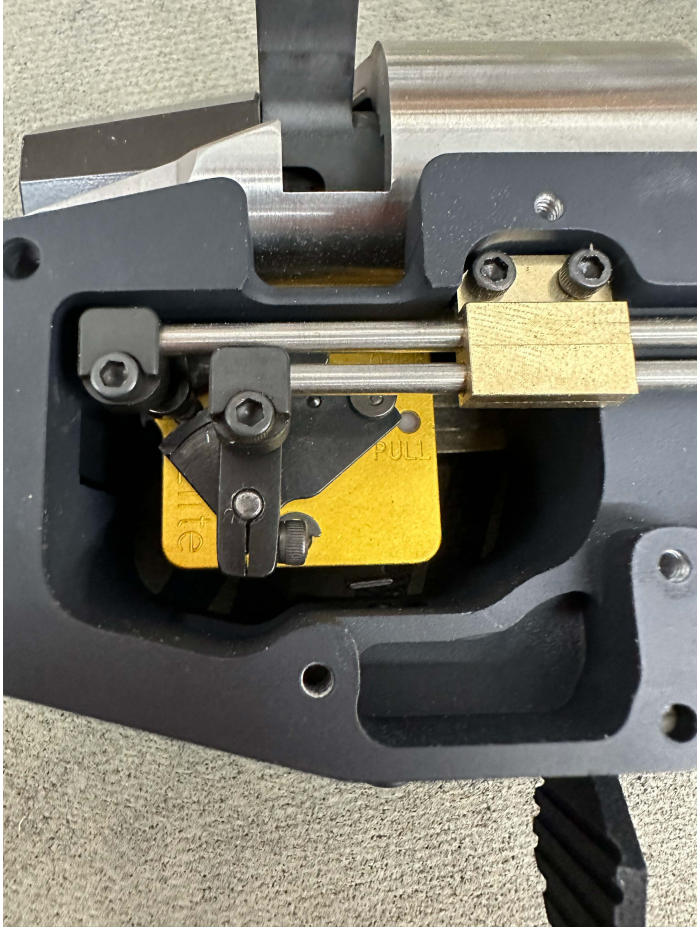

Rear Left Side

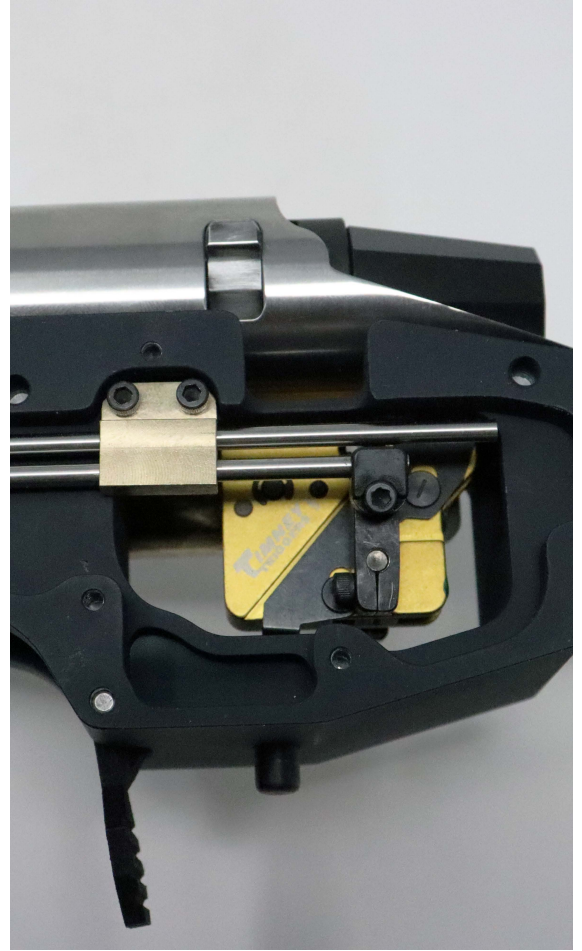

Front Right Side



Front Left Side



## 3.6 Assembling The Rest of the MK2.5

Verify your trigger and safety are functioning properly. Make sure your trigger op rods look identical on each side, as this is imperative for a pull that doesn't induce any uneven force on one side. You will find trigger feel is changed as you adjust the linkage, you can also adjust the front of the linkage to alter where your trigger sets in relation to the trigger guard.

Bolt on your side plates, use reasonable torque to prevent stripping the 4-40 size chamfer head bolts. Low strength thread locker can prevent these from backing out.

Two bolts now install your butt section, make sure to adjust your LOP to allow the bolt to clear, we prefer it to just barely clear with the bolt fully rearward.

The forend is installed via (4) chamfer head 1/4-20 bolts. Reasonable torque and no stronger than medium strength thread locker is suggested.

The scope hood is installed with (6) bolts you removed earlier. Make sure that all wholes are lined up. If desired it can be threadlocked to approximately 12-15 in/lbs.

Two button head bolts now install your cheekpiece. You should be ready to rock! Let us know if you have any questions, we are happy to help.

support@mkmachining.com    573-220-9141

