

TZ-862

Electronic Pet Fence System Operating Guide

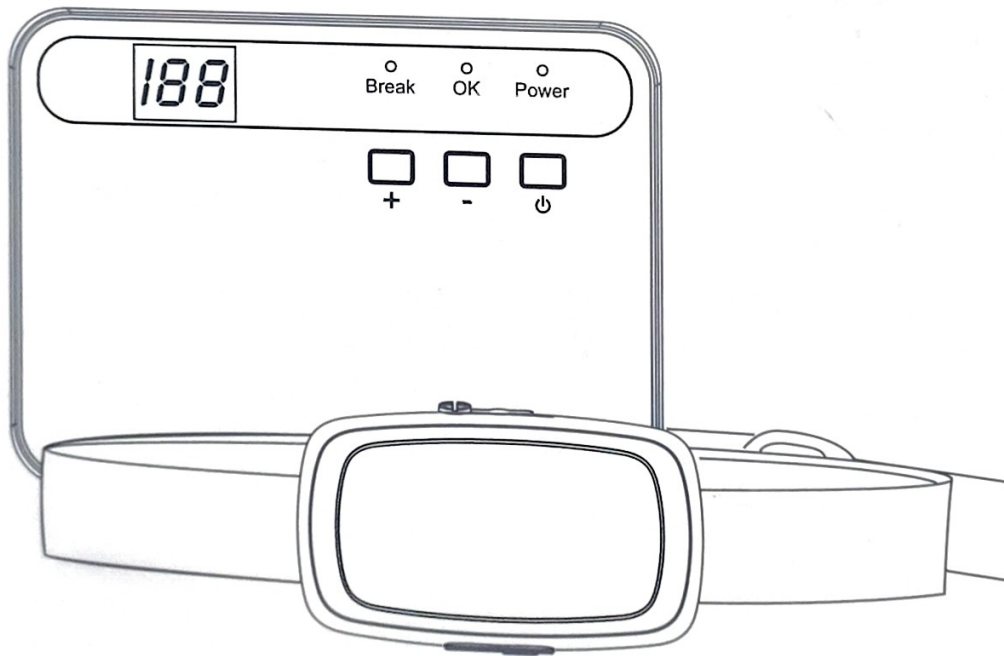

This system will make sure your dog stay safe in the yard.
Please read this entire guide before operation.

Thanks for choosing the more effective and reliable Electronic Pet Fence System for your family pet.

Table of Contents

Product Description	2
Main Features	2
Package Contents	3
Installation of Fence System	4
Verify the Function of Fence System	6
Put Receiver Collar on Your Dogs	7
How the Correction Works	8
System Maintenance Tips	8
Troubleshooting Guidelines	9

Precautions

DO NOT use this product for aggressive dogs or vicious animals.

Risk of skin damage.

It's important to fit the collar properly. A collar that is fitted too tightly or worn for too long may harm your dog's skin. This condition, which ranges from redness to pressure ulcers, is commonly known as bed sores.

Please charge the receiver collar before training!

You should fully charge it when not in use, and charge it every month.

Electronic Pet Fence System TZ-862

I. Product Description

This TZ-862 electronic pet fence is a reliable and cost-efficient pet containment system. The harmless radio signal given by the transmitter goes through the wire to the boundary of the "yard".

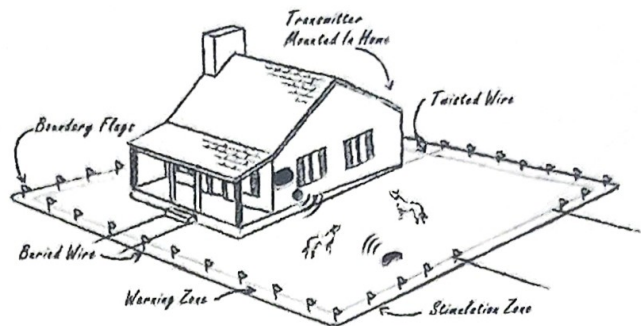

The slow warning beep is activated after received the signal from wire, when your dog wears the collar to approach the boundary wire. If the dog go ahead to the boundary wire, then the rapid warning beep and mild electric shock are administered at the same time. The frequency of the warning beep and electric shock will be increased to encourage your dog to return to the safer areas of your yard. Note: The intensity of the electric shock is fixed and won't be increased.

II. Main Features:

1. Proportional Warning Beep and Electric Shock:

2. 100 Levels to Adjust on the Transmitter:
Different levels suit for different range of yard;

3. Variable Field Width Control:

Allows you to control the width of the signal field precisely;

4. Waterproof & Rechargeable Collar

5. Audible and Visual Wire Break Indicators:

Once the buried wire was broken, a loud sonic alarm will be issued with a flashing light;

6. Multiple Collars Operation:

Multiple collars are available if you have more than one pet.

7. Up To 2500 Square Meters Range (over 0.617 acres).

III. Package Contents:

TZ-862(1 for 1)

- 1. Transmitter * 1
- 2. Receiver Collar * 1
- 3. Adapter * 1
- 4. Boundary Flags * 20
- 5. Screw Plastic Expansion Tube * 2
- 6. Screws * 2
- 7. 200-meter Wire * 1
- 8. Metal Probes * 4
- 9. Mini Spanner * 1
- 10. Test Light * 1
- 11. USB Charging Cable * 1
- 12. Operating Guide * 1

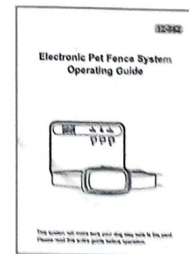
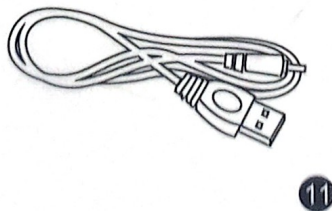
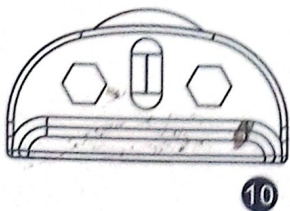
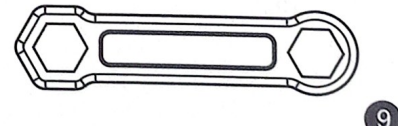
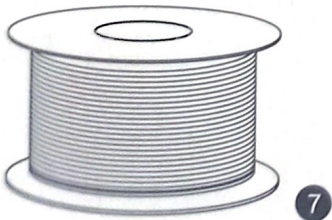
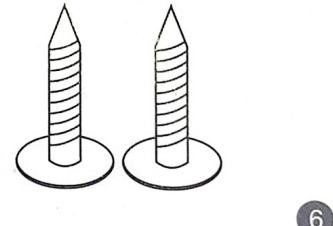
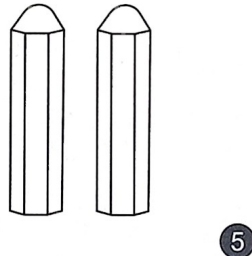
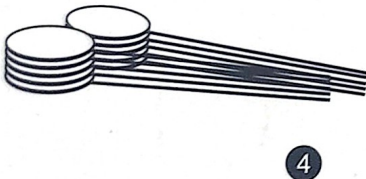
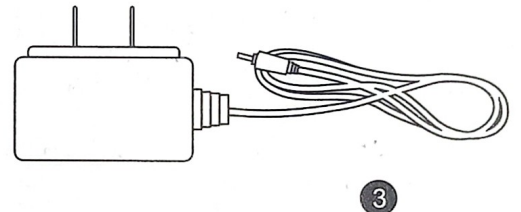
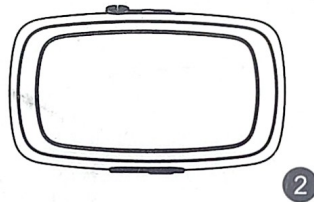
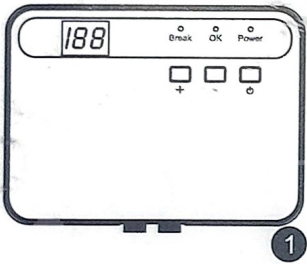

200-meter Wire: connecting the 2 ends of Transmitter and Transmitting radio signal.

Boundary Flags: showing where is the fence wire that you buried.

Metal Probes: fixing the belt; you may need to replace between the shorter and longer metal probes.

Test Light: checking if there is electrical stimulation when the Receiver Collar working.

Screws and Screw Plastic Expansion Tube: fixing the Transmitter onto the wall

Mini Spanner: using to screw the Metal Probes.

If you buy the **TZ-862 (1 for 2)**, here are all accessories:

- | | |
|-------------------------------------|-------------------------|
| 1. Transmitter * 1 | 2. Receiver Collar * 2 |
| 3. Adapter * 1 | 4. Boundary Flags * 20 |
| 5. Screw Plastic Expansion Tube * 2 | 6. Screws * 2 |
| 7. 200-meter Wire * 1 | 8. Metal Probes * 8 |
| 9. Mini Spanner * 2 | 10. Test Light * 2 |
| 11. USB Charging Cable * 2 | 12. Operating Guide * 1 |

IV. Installation of Fence System

To make sure the fence system works smoothly, you should design a diagram of the fence area at first. Then mount the transmitter nearby the AC outlet, set the boundary with wire and flags and place the receiver collar on your dogs' necks.

Please install the system as below steps:

Step 1: Mount the transmitter

To make the transmitter work properly, you should ensure there is a 110/220V AC outlet before mounting it . Place the transmitter on the wall or in the tree and fix it with screws.

Step 2: Install the boundary flags and connect the wire

Firstly, connect the end of the wire to one of the wire terminals on the transmitter (red/black), mount the boundary flags one by one according to the boundary layout. Meanwhile, bury the wire around the perimeter of your yard and plug the flags near wire to mark the boundary.

Then connect the other end of the wire to another wire terminal on the transmitter (black/red).

Please keep the excess wire around the bobbin.

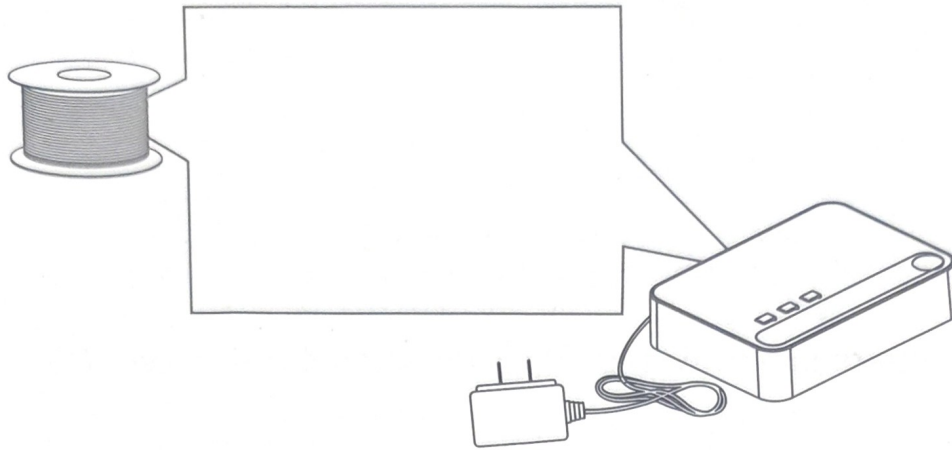

Notice: The wire length is 200 meters. You can extend the wire length to expand the boundary, but the total wire length should be less than 300 meters.

Step 3: Set parameters for the transmitter

The signal field is the distance between the wire and the place where the receiver collar first is activated.

Press ON/OFF button to turn the transmitter ON/OFF.

The control range means the shortest distance between boundary wire and the receiver collar.

The higher signal level is, the bigger the control range will be.

The "+" / "-" button on the transmitter is to adjust the transmitter signal intensity instead of the correction intensity.

Press the "+" button to expand the control range the "-" button to narrow it.

Set up the power level of transmitter signal properly by following below table.

(P.S: Below data just for reference)

Control Range(meter)

Transmitter Signal Level	200m wire	100m wire	60m wire
100	3.2m	6.0m	Unavailable
90	3.0m	5.0m	Unavailable
80	2.9m	4.3m	Unavailable
70	2.8m	4.2m	5.0m
60	2.7m	4.0m	4.7m
50	2.6m	3.5m	4.6m
40	2.5m	2.5m	4.1m
30	2.0m	2.2m	3.5m
20	1.6m	1.8m	2.9m
10	1.2m	1.3m	2.3m
5	1.0m	1.1m	1.0m
1	0.8m	1.0m	1.0m

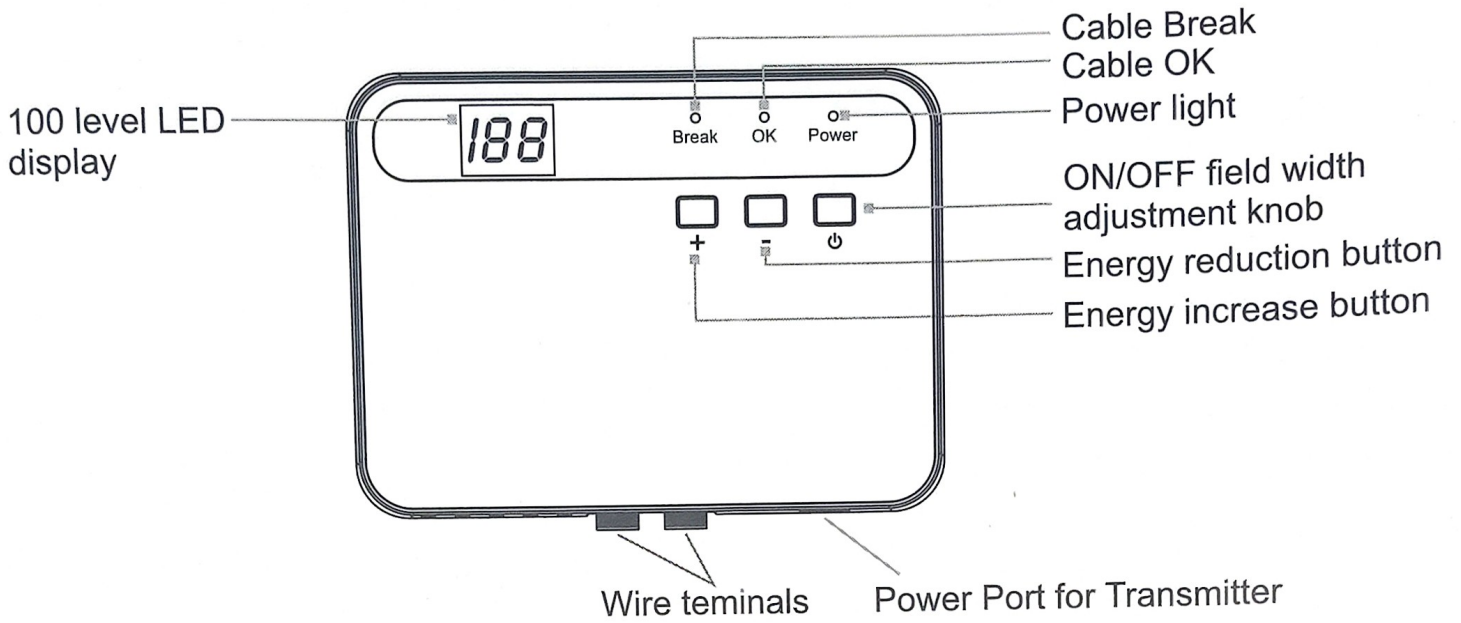

V. Verify the Function of Fence System

Set the proper control range by pressing the “+”/”-” button to adjust the desired signal level according to the table above.

For example, set the signal level at 10, then take the receiver collar to the place where is 0.5 meter away from the boundary wire.

Press ON/OFF button on the receiver collar to turn it on and then move the collar slowly towards the boundary wire.

Place the LED test light on metal probes of the receiver collar after hearing the “bi-bi” warning tone from the receiver collar, the test light will be on for a few seconds. Now you move the receiver collar away from the boundary, the receiver collar will stop working once it is beyond the control range. If the receiver collar doesn’t beep or the test light isn’t on, please make sure all the wires are connected correctly. If it’s still not working, then the fence system is faulty.

Notice: DO NOT place the receiver collar on your dog before the fence system has been tested and the signal field has been adjusted. You should test the fence system manually using the provided test light to verify that the signal is properly transmitted through the wire.



Choose the longer probes or shorter probes to use according to the length of dog's fur.



Never connect a leash to the collar.



Never leave the collar on your dog more than 12 hours a day.

VI. Put the Receiver Collar on Your Dogs

Make sure the 2 metal probes have already been screwed on the receiver collar firstly. Place the collar around the dog's neck with the receiver case under the chin. Adjust the collar using the adjustable buckle arrangement provided with the strap. The unit should fit snugly underneath your dog's neck. Make sure that the probes are in direct contact with your dog's skin. Notice: Always make sure the collar is functioning properly BEFORE putting it on the dog.

Center the Contact Points under your dog's neck

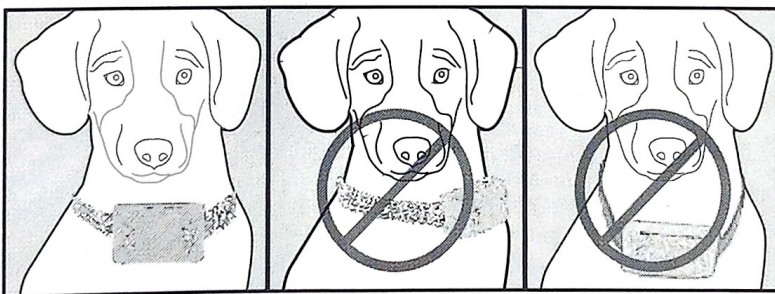

Important: Make sure that you can fit one finger between the strap and your dog's neck.



VII. How the Correction Works

When your dog wears the collar to walk enter the pre-set control range in the yard, the slow warning beep is activated after received the signal from wire, if the dog go ahead to the boundary wire, then the rapid warning beep and mild electric shock are administered at the same time. The frequency of the warning beep and electric shock will be increased to encourage your dog to return to the safer areas of your yard.

VIII. System Maintenance Tips

In fact, only a little maintenance is required for the receiver collar, since it's rechargeable and waterproof. While the transmitter is not waterproof. You should protect the transmitter from the bad weather, as a close lighting strike may damage the unit. Unplug the transmitter and disconnect the wires when there is a storm.

Note: the Red LED on the collar keeps to slow flash with 30 seconds, and turn off automatically, means Receiver Collar needs to recharge.

The Red LED will be slow flash during charging.

The Red LED will be steady lighting when charged full and please remove the charging cable and put back the rubber cover.

Test the system once a week to make sure the receiver collar is working properly and the field width setting is correct.

Attaching the Test Light to the receiver collar's probes to test.

Holding the receiver case (NOT the probes), walking into the signal field and paying attention to the warning tone and LED lighting inside of test light.

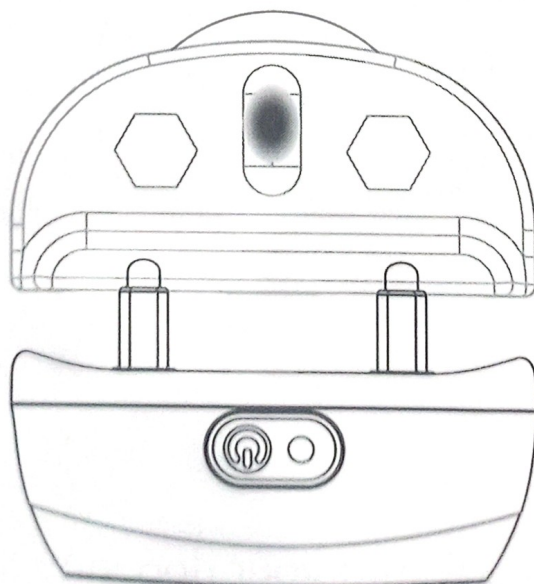

IX. Troubleshooting Guidelines

A. Dog is not responding to correction:

Pay attention to below points:

- 1) Check the collar strap and make sure it is wearing properly.
- 2) Trim the dog's hair or use longer probes to make sure the probes are in the direct contact with your dog's skin.
- 3) Please charge the receiver collar if the battery is low.

B. System Test Procedure:

When you experience a malfunction, you will need to do a Test Loop to find which component - the receiver collar, the transmitter or the yard wire - is not working.

To perform the Test Loop procedure:

1. Make a test loop using a wire that is at least 4 meters.
2. Remove the existing wire from your wall transmitter.
3. Insert the two ends of the test loop wire into the wall transmitter.
4. Set the field width level to a low setting.
5. Place the test light on the receiver collar. With the collar in hand, move outside the field and approach the test loop. Keep the distance between the collar and the wire in mind when the collar is activated.
6. Set the transmitter signal level to a medium value, such as 40.
7. Walk back and forth to find the corresponding distance of this level.
8. Repeat the above test steps on each collar if there is more than one receiver collar is applied to the system.