

MAHLE X20 System
User Manual

X20

Index

1. Introduction

1.1 General Warning	4
1.1.1 About Warnings.....	4
1.2 Maintenance, Storage & Transportation	4
1.2.1 Drive Unit, HMI and Accessories care	5
1.2.2 Battery Packs care	5
1.2.3 Charger care	5
1.2.4 Ebike care	5
1.3 Transportation of your eBike system	5
1.3.1 Transportation full eBike by car	5
1.3.2 Transportation full eBike by air	5
1.3.3 Transportation full eBike by train	5
1.3.4 Transportation of batteries for repair	5
1.4 Safe Charging Process	6
1.5 Servicing	6
1.6 Recycling	6
1.7 Product Certifications	6
1.7.1 Important information about HMI	6

2. General overview

2.1 Specifications	9
2.1.1 X20 Drive Unit.....	9
2.1.2 X20 Torque & Cadence Sensor	9
2.1.3 iX250 – X20 Internal Battery	9
2.1.4 iX350 - X20 Internal Battery	9
2.1.5 HMI Head Control Unit	10
2.1.6 X20 Dropout Drive Unit Connector	10
2.1.7 Charger Port.....	10
2.1.8 Active Charger	10
2.2 Compatible eBikes	10

3. Operation and use

3.1 Operation Mode	11
3.2 Use Cases.....	11
3.2.1 Planned use	11
3.2.2 Prohibited Use.....	11
3.2.3 Operative mode (In the event of malfunction)	11
3.3 Operation	12
3.3.1 Switching the system ON / OFF	12
3.3.2 Automatic System Switching OFF	12
3.3.3 Change the assist level	12
Control the assist level using the HMI	12
Control the assist level using e-Shifters.....	12
Control the assist level using Pulsar ONE display	12
3.4 Switching the lights ON/OFF	13
3.5 Walk-assist Mode	13
3.6 Information of the Head Unit - LED	13
3.6.1 (SOC), State of Charge of the battery	14
3.6.2 Current Assist Level.....	14
3.6.3 Set the intensity of the LEDs.....	14
3.6.4 Other Information displayed by the HMI..	14

3.7 Operation with the Charger	15
3.7.1 X20 SmartBike Active Charger	15
3.7.2 Charging Process	15
Error while charging process.....	15
3.8 Updating Process.....	15
3.8.1 Uploading files to the Active Charger	15
3.8.2 Updating eBike system.....	16
3.9 Battery Use	16

4. Accessories

4.1 Pulsar ONE display.....	16
4.1.1 Pulsar ONE holders	17
4.2 e-Shifters.....	17
4.2.1 e-Shifters Installation	17
4.3 e185 - Range Extender	18
4.3.1 Range Extender Pack Components.....	18
4.3.2 Range Extender Wires	19

5. Application and Services

5.1 My SmartBike phone APP	20
5.1.1 Smartphone APP. Main Functions.....	20
5.1.2 Smartphone APP. Motor settings	20
5.1.3 Smartphone APP Account creation	21
5.2 My Smarbike Web APP	21
5.2.1 Web APP. Main Functions.....	21
5.2.2 Web APP. Account creation	22

6. Service

6.1 Rear wheel removal and installation	22
6.1.1 Rear wheel removal	22
6.1.2 Rear wheel installation	23
6.2 Other Services	23
6.2.1 Freewheel and bottom bracket servicing	23
6.2.2 Battery, Motor, Head Unit Servicing	23
6.2.3 Replacing Automatic Dropout Connection.....	24
6.3 Warranty	24
6.4 FAQs	24
6.5 Error Codes.....	25

1. Introduction

Thank you for choosing the MAHLE X20 System for your new SmartBike.

Please read this manual carefully before operating the system. Failure to do so or misunderstanding its instructions may lead to serious injuries or death.

Products and specifications are subject to change without prior notification thereof.

This Document has been drawn up in English and the content herein shall prevail in the event of any translation error or misunderstanding in its interpretation by the client of translations herein.

This manual includes instructions for the X20 Series System, including the following components:

- Drive Unit
- Head Unit
- Internal Battery Packs
- Torque and Cadence Sensor
- Active Charger

All relevant documents of the X20, including this user's manual can be downloaded from our website: www.mahle-smartbike.com

The X20 components are certified as a complete system to guarantee full safety of the system. Any component can only be replaced with an original replacement of MAHLE SmartBike Systems to maintain the safety of the full system. Any tampering, modification, or reparation by any non-MAHLE authorized third-party shall immediately void the warranty conditions and original certification, holding MAHLE harmless with regard to any civil liability.

Repairs or replacement must be performed by MAHLE SmartBike Systems, hereinafter MAHLE if applicable, certified partners only.

This manual shall not be reproduced other than in its entirety, except when prior written approval has been obtained from MAHLE SmartBike Systems.

1.1. General Warning

Please pay special attention to any warning symbol within the system highlighted with these graphics.

 DANGER

 WARNING

 CAUTION

 NOTICE

1.1.1. About Warnings

This manual contains DANGER, WARNING, and CAUTION indicators, concerning the consequences of failure to use, assemble, maintain, store, inspect and dispose of MAHLE-equipped eBikes in a safe manner. The combination of the safety alert symbol and the word DANGER indicates a hazardous situation that, if not prevented, could lead to death or serious injury.

Preserve all safety warnings and instructions for the future. Do not open the Drive Unit or the Battery Pack by yourself. The system is maintenance-free. It must only be opened by qualified experts and repaired with original spare parts and specific tools. Unauthorized opening of a system would lead to voiding the warranty. All components of the Drive Unit and eBike may only be replaced with identical components or specifically approved by your eBike manufacturer. This protects your eBike system from damage. Don't modify the Drive Unit, the battery or any other component or add any other non-approved product to improve performance or tampering. There is risk of accident in the event of accidental activation. Be careful when touching the surface of your Drive Unit. The surface may heat up considerably and cause skin burns. The walk-assistance function may only be used when pushing the eBike and require specific remotes. There is risk of injury if the wheels do not have ground contact when using this function. Use only original MAHLE batteries approved by the eBike manufacturer. Using unauthorized batteries may cause injuries or fire. Observe your regional and local regulations in reference to eBikes and pedelecs.

1.2. Maintenance, Storage & Transportation

The Drive Unit, batteries and main components are designed for long-term use and require following some simple and understandable guidelines to extend the lifespan of the MAHLE System by taking proper care during the use, cleaning and transportation thereof.

Children must not play with the components or full eBike System.

- Contact the place of purchase or a bicycle dealer for information on installation and adjustment of the products which are not found in the user's manual.
- Do not disassemble or alter this product.
- These are small waterproof connectors. Do not repeat connecting and disconnecting it. It may impair the function.
- The components are designed to be fully waterproofed to withstand wet weather riding conditions; however, do not deliberately place them in water.
- Do not clean the bicycle in a high-pressure car wash. If water gets into any of the components, operating problems or rusting may occur.
- Do not use thinners or similar substances to clean the products. Such substances may damage the surfaces.
- Be careful not to let water get into the terminal.

Products are not guaranteed against natural wear and tear from normal use and aging. The X20 can be installed in kid's eBikes. For this type of use, ensure that your child is supervised and follow the eBike manufacturer's safety instructions.

Cleaning and user maintenance shall not be executed by children without supervision.

1.2.1. Drive Unit, HMI and Accessories care

Remove any dust or mud on the surface of your Drive Unit, the HMI (displays, buttons, or remotes) and external accessories with a clean cloth. Never wash any of your eBike components using a power washer.

It is possible to clean or replace the freewheel and the bottom bracket by following the specific instructions in this manual or in manual of the bicycle manufacturer.

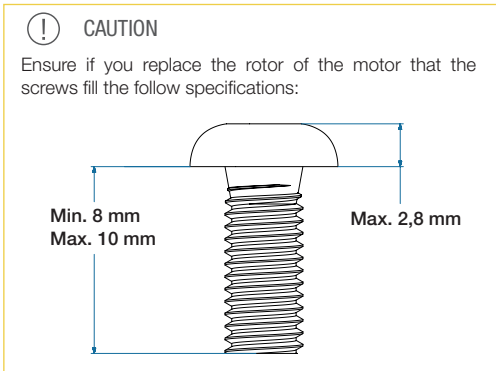

1.2.2. Battery Packs care

The batteries, especially the internal ones, only require removal if being replaced by an official service. They include sealed connections that protect against short circuits. Do not manipulate or connect anything in between the components. Never wash external batteries by using a power washer.

1.2.3. Charger care

Disconnect the charger and all general power supply for any cleaning operation. The charger is designed for indoor use only. Do not expose it to wet conditions, rain or snow.

1.2.4. eBike care

Keep your eBike system clean and dry for long-term or winter storage. We do recommend a charging level of at least 60-80% during long-term storage. To ensure a correct level of charge, you can either check the length of the HMI LED line, connect the Pulsar ONE display or the Smartphone application to the bike.

The power consumption can significantly increase during use in winter, especially when the temperature drops below 0 °C. Please fully charge the eBike and external batteries before any winter use and remember that the range of your eBike could be reduced.

1.3. Transportation of your eBike system

There is a clear regulation for the transportation of the eBikes and batteries by ground, air/boat or train. There are global recommendations with regard to internal and external batteries. Remember that in all cases, the best option is to transport the battery when it is below 30% charged. For full eBike system, check the local regulations.

1.3.1. Transportation of full eBike by car

The internal battery shall not be removed from the bike for transportation. External batteries need to be removed and transported in a safe area inside the car.

1.3.2. Transportation of full eBike by air

The IATA (International Air Transportation Association) refuses to transport any eBike batteries. Please check if you can transport your eBike without the internal battery, send the battery separately and have it installed at your destination.

1.3.3. Transportation of full eBike by train

In most cases, eBikes are permitted to be transported inside trains, if the train does not provide a specific safe area for transportation. Check your local regulations or with your transportation company before setting off on your trip.

1.3.4. Transportation of batteries for repair

If, for any reason it is necessary to ship the battery, this needs to be done by an official service following the specific rules for transportation of dangerous goods, the recommendations of MAHLE and the eBike manufacturer. The battery needs to be placed in a specific, certified box and complemented with all the official documentation i.e., the MSDS report. This process cannot be performed by private persons.

1.4. Safe Charging Process

The X20 System includes a Smart Charger that establishes a direct connection with the MAHLE X20 internal and external batteries, supplying the correct charging current and the ideal balancing of the cells. Please only use MAHLE X20 original chargers for charging the MAHLE X20 Range Extenders or internal batteries and ensure the battery and charger are compatible. Charger and batteries are fully qualified for being used under the current regulations of the regions that X20 is approved to be used in.

- Connect the charger directly to a power source.
- Never use extension cords.
- Avoid reverse charging.
- Do not use for non-rechargeable batteries, as they can overheat and break.
- The Active Charger is not intended to charge automobile batteries.
- Inspect the Active Charger before every use for possible damage of the charger, the wire or and charging plug. Do not cover the charger while charging.
- Regularly inspect the battery. Never charge a battery which is potentially damaged or does have a defect.
- Make sure the charging socket and plug are not wet or humid before connecting and charging the battery.
- If the eBike or the battery are excessively cold, please wait until the warmed up before charging the system.
- Do not incinerate, disassemble or short circuit batteries.



WARNING

Explosive gases. Prevent flames and sparks. Ensure that there is adequate ventilation during charging. Charger is designed for indoor use only. Misused other types of batteries may burst, causing personal injury and damage. Do not incinerate, disassemble, or short circuit batteries or the charger.

1.5. Servicing

Servicing, replacement and repair may only be performed by official MAHLE Service Partners. In the event of repair, the MAHLE Service must authorize the process. Please remember that our components may contain cells (i.e., internal batteries) that can be damaged, or a short circuit could be created by drilling into the frame, which could result in a fire.

The capacity of a battery will degenerate over time. During normal use of 2 years or after 500 full charging cycles, the battery can degrade to around 70% of its initial capacity. To obtain 100% capacity again, the battery must be replaced. Waterproofness and integrity of the battery cannot be guaranteed once the battery has been opened.

1.6. Recycling

It is our responsibility to ensure the correct recycling of the battery. Together, we are responsible for minimizing the CO2 footprint and environmental impact. Please ensure the correct recycling of the battery when reaching the end of its lifespan. Get in touch with your dealer or eBike manufacturer to ensure the correct recycling process. If the battery needs a replacement, please bear in mind that only official MAHLE service partners are allowed to replace the internal battery. They can also handle the recycling of your old battery.

According to the European Guideline 2012/19/EU, electrical devices / tools that are no longer usable must be collected separately and disposed of in an environmentally correct manner. This product must be disposed of at an authorized place for recycling of electrical and electronic appliances. Please also take into account the regional regulations of your country.

By collecting and recycling waste, you are doing your bit to save natural resources, and make sure the product is disposed in an environment friendly and healthy way.

1.7. Product Certifications

MAHLE SmartBike Systems SLU hereby declares under its own responsibility that the design and construction of the product complies to the Safety requirements of application under European Standard EN 15194:2017, the follow European Directives: [MD] 2006/42/CE, [EMC] 2014/30/EU, [RED] 2014/53/CE (HMI), [BAT] 2006/66/EU (Battery Packs), [LVD] 2014/35/EU (Battery Charger) and [RoHS III] and Regulation [REACH].

The complete document about product certifications is available at the following link:

<https://www.mahle-smartbike.com/conformity>

1.7.1. Important information about HMI

Model: HUS

FCC STATEMENT



CAUTION

If any changes or modifications not expressly approved by the party responsible for compliance could void the user's authority to operate the equipment.

This device complies with Part 15 of the FCC Rules.

Operation is subject to the following two conditions: (1) This device may not cause harmful interference, and (2) This device must accept any interference received, including interference that may cause undesired operation

The grantee is not responsible for any changes or modifications not expressly approved by the party responsible for compliance therewith. Such modifications could void the user's authority to operate the equipment. The RF Exposure Compliance distance is 20 millimeters.

↔ NOTICE

This equipment has been tested and found to comply with the limits for a Class B digital device, pursuant to part 15 of the FCC Rules. These limits are designed to provide reasonable protection against harmful interference in a residential installation. This equipment generates, uses and can radiate radio frequency energy and, if not installed and used in accordance with the instructions, may cause harmful interference to radio communications. However, there is no guarantee that interference will not occur in a particular installation. If this equipment does cause harmful interference to radio or television reception, which can be determined by turning the equipment off and on, the user is encouraged to try to correct the interference by one or more of the following measures:

- Rotate or relocate the receiving antenna.
- Increase the separation between the equipment and receiver.
- Connect the equipment into an outlet on a circuit different from that to which the receiver is connected.
- Consult the dealer or an experienced radio/TV technician for help.

ISED Statement

This device complies with Innovation, Science and Economic Development Canada license-exempt RSS standard(s). Operation is subject to the following two conditions: (1) this device may not cause interference, and (2) this device must accept any interference, including interference that may cause undesired operation of the device.

CAN ICES-3(B)/NMB-3(B)

Le présent appareil est conforme aux CNR Innovation, Sciences et Développement économique Canada applicables aux appareils radio exempts de licence. L'exploitation est autorisée aux deux conditions suivantes:

(1) il ne doit pas produire de brouillage et (2) l'utilisateur du dispositif doit être prêt à accepter tout brouillage radioélectrique reçu, même si ce brouillage est susceptible de compromettre le fonctionnement du dispositif.

CAN ICES-3(B)/NMB-3(B)

The device meets the exemption from the routine evaluation limits in section 2.5 of RSS 102 and compliance with RSS-102 RF exposure, users can obtain Canadian information on RF exposure and compliance.

Le dispositif rencontre l'exemption des limites courantes d'évaluation dans la section 2.5 de RSS 102 et la conformité à l'exposition de RSS-102 rf, utilisateurs peut obtenir l'information canadienne sur l'exposition et la conformité de rf.

This transmitter must not be co-located or operating in conjunction with any other antenna or transmitter. This equipment should be installed and operated with a minimum distance of 20 millimeters between the radiator and your body.

Cet émetteur ne doit pas être Co-placé ou ne fonctionnant en même temps qu'aucune autre antenne ou émetteur. Cet équipement devrait être installé et actionné avec une distance minimum de 20 millimètres entre le radiateur et votre corps.

B급 기기 (가정용 방송통신기자재)	이 기기는 가정용(B급) 전자파적합기로서 주로 가정에서 사용하는 것을 목적으로 하며, 모든 지역에서 사용할 수 있습니다.
Class B Equipment (For Home Use Broadcasting & Communication Equipment)	This equipment is home use (Class B) electromagnetic wave suitability equipment and to be used mainly at home and it can be used in all areas.

⚠ WARNING

This product contains chemicals known to the State of California to cause cancer and birth defects or other reproductive harm.

MAHLE hereby declares that the radio equipment type of this HUS is in compliance with Directive 2014/53/EU. The full text of the EU Product certifications is available at: www.mahle-smartbike.com



HMI Designed by MAHLE in Europe.
HMI Assembled in PRC.

2. General Overview

You have bought an eBike that includes a MAHLE X20 SmartBike System. This system is designed to support you while you are pedaling under the regional regulations of your country for this application. The X20 is composed of:

1 X20 Drive Unit



2 X20 Internal Battery (iX250 or iX350)



3 X20 HMI Control Unit (Button & LED line display)



4 X20 Charging port

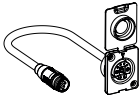

5 X20 Torque & Cadence Sensor

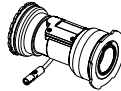

6 Wires & adapters



Accessories

A Pulsar ONE display



B e-Shifters

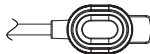

C Range Extender

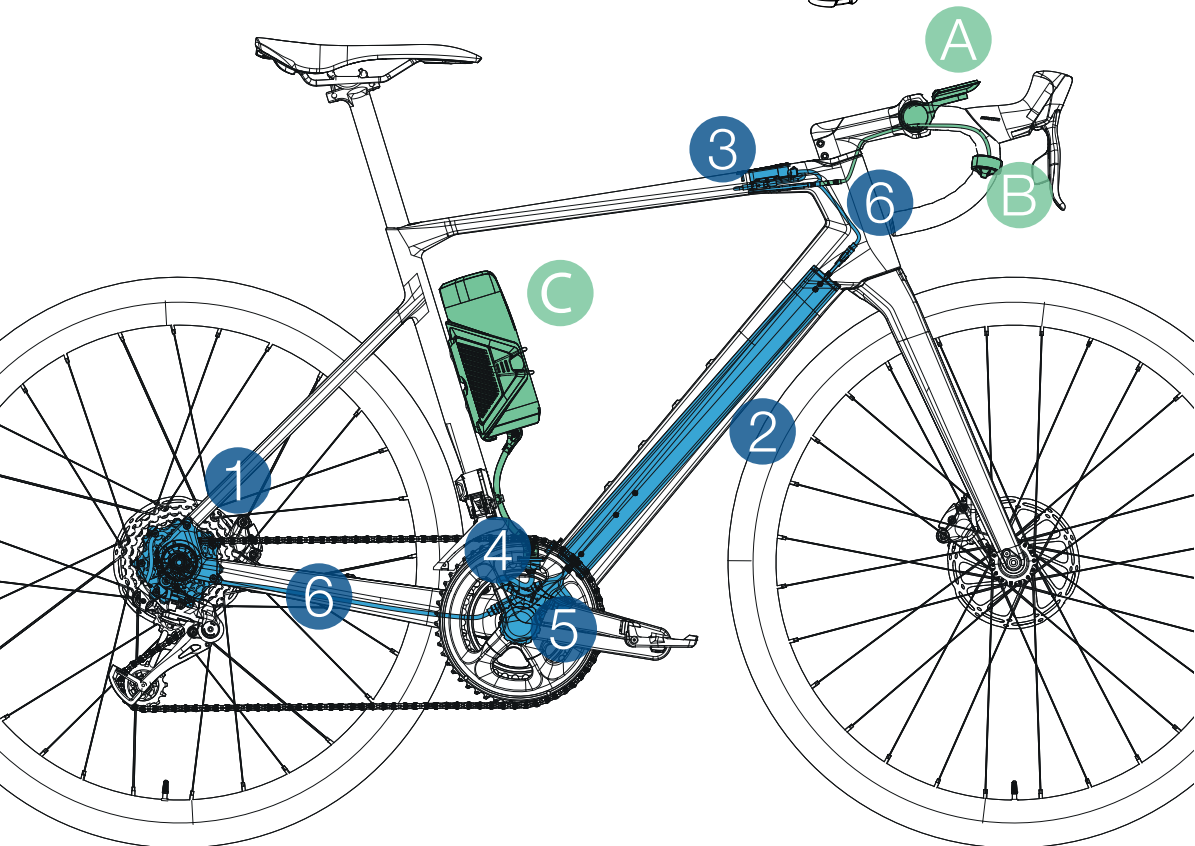

2.1 Specifications

Main Component Specifications

2.1.1. X20 Drive Unit

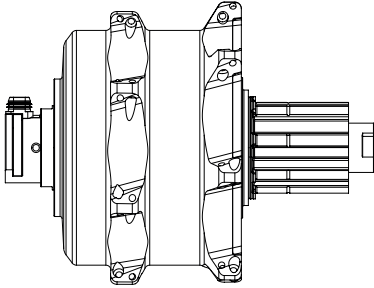

- R142 O.L.D. and Thru Axle (12 mm)
- 28 Straight-pull spokes
- 14G Standard
- Nominal voltage CA: 42 V
- 55Nm (Compared to Mid Drive)
- Compatible with 140mm flat mount calipers
- Max. Speed: 25km/h or 20 mph (Limited per region)
- Automatic Motor Connection System
- Standard Freewheel installation
- CAN BUS Interface
- Water ingress protection: IP64
- Weight: 1,399 grs (without freewheel)

2.1.2. X20 Torque & Cadence Sensor

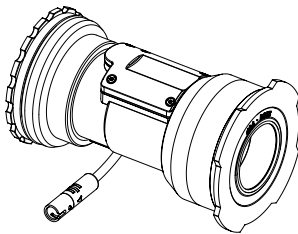

- Nominal voltage CC: 6V
- Designed for press-fit BB shells
- 4 different models available (Dimensions depending on the version and standard used)
- Cadence and torque reading
- Compatible with all spindles on the market
- Mixed press-fit and threaded mechanism
- 92 mm wire to battery
- CAN BUS Interface
- Water ingress protection: IP54

2.1.3. X250 – X20 Internal Battery

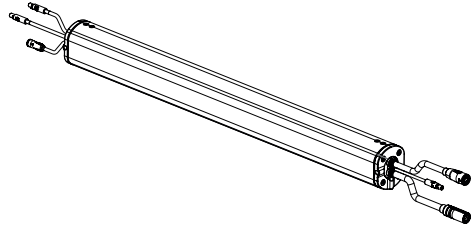

- Nominal voltage CA: 25-42 V
- Voltage & charging current CC: 42C – 2.1A / 4A
- Capacity: 236Wh / 36V
- Dimensions: 469.5 x 49.6 x 41.8 mm (LxWxH)
- CAN BUS Interface
- Water ingress protection: IP66
- 2 HMI-; Accessories connectors
- Light support 2A/6V (12W)/12V (24W) USB 2A/5V
- Weight: 1,500 grs

2.1.4. iX350 - X20 Internal Battery

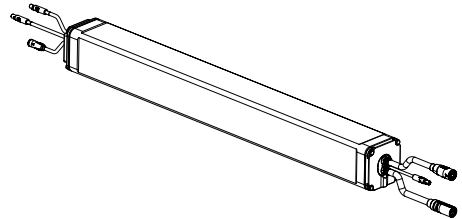

- Nominal voltage CA: 25-42 V
- Voltage & charging CC: 42C – 2.1A / 4A
- Capacity: 350Wh / 36V
- Dimensions: 469.5 x 51 x 52 mm (LxWxH)
- Water ingress protection: IP54
- CAN BUS interface
- 2 HMI Accessories connectors
- Light support 2A/6V (12W) /12V (24W), USB 2A/5V
- Weight: 2,250 grs

2.1.5. HMI Head Control Unit

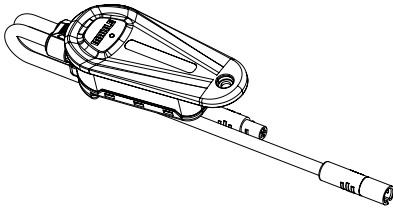

- Voltage CC: 6V
- Ambient temperature: 60 C / -10C
- Dimensions: 73.1 x 28.2 x 18.9 mm (LxWxH)
- CAN BUS, ANT+ and Bluetooth® Interface
- Water ingress protection: IP54
- Weight: 32 grs

2.1.6. X20 Dropout Drive Unit Connector

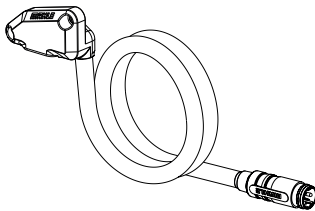

- 550 mm cable length
- Water ingress protection: IP54
- Weight: 64 grs

2.1.7. Charger Port

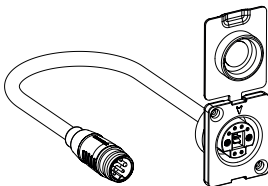

- 6-pin connector with poka-yoke connection
- Water ingress protection: IP54
- Weight: 24 grs

2.1.8 Active Charger

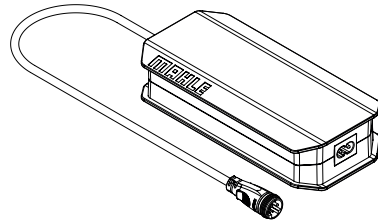

- Nominal voltage AC: 90-246V, 50-60 Hz
- Nominal voltage CA: 42 V – 2.1A / 4A
- Voltage & charging CC: 42C – 2.1A / 4A
- Ambient temperature: 90 C / -15C
- Dimensions: 187 x 90 x 44.4 mm (LxWxH)
- Water ingress protection: IP20
- Weight: 690 grs

2.2 Compatible eBikes

The X20 System can only be assembled on eBikes which were designed for the integration of X20 components. An aftermarket- or retrofit application is not possible. The eBike need to pass all the certifications and homologations required by the specific regions in which the bike is going to be sold. Please check the official MAHLE SmartBike Systems website in order to access our most updated list of eBikes on the market with our X20 System:

Website: www.mahle-smartbike.com

3. Operation and use

Thanks for purchasing an eBike that includes the MAHLE X20 System. This system includes a lot of connectivity features as well as AI functions that will give to you the chance to entry in the era of the new SmartBikes. This chapter explains how to use the system and you must read before any operation of you eBike system.

3.1. Operation Mode

In order to operate the system in a correct way, ensure that the eBike system (including the rear wheel) is fully connected and correctly assembled.

To ensure a correct use of the eBike system, first disconnect the charging wire from the charging port of the eBike. Do no ride the eBike while it is charging.

Ensure that eBike is fully charged before using it for the first time. To ensure your bike is fully charged, we recommend keeping the eBike system connected to the power supply and charger for at least 2 hours. For additional information on how to charge your eBike, please check the chapter "Operations with the Charger / Charging Process".

Before starting your ride always ensure your battery is sufficiently charged. Disconnect the charger of your eBike and switch the system on by pressing the button of the Head Control Unit once.

3.2. Use Cases

The X20 System is designed to be used as an electronic component of a compatible full eBike.

3.2.1. Planned use

The intended use of our product is to assist the pedaling of an EPAC (not for any other eBike application). All the X20 components were designed to be integrated in a complete eBike produced by a professional bicycle manufacturer.

The system is designed to be used under the current harmonized norms and certifications:

- Europe: EN15194:2017
- US / CAN (in progress!!): UL2849, UL 1310 (battery charger)
- Australia: EN15194

Our product is designed under the requirements, which the standards established for being used in EPAC applications and certain environmental conditions in which this kind of applications may be used like rain, salty areas, mud, etc.

The MAHLE X20 System overachieves what the standards require, but please also pay attention to what the eBike manufacturer specifies regarding the system integration and design information. Pay special attention to:

- Mounting and dismounting of the rear wheel, the PAS and the torque sensor inside the bottom bracket.
- Clean the system only under the specific MAHLE recommendations inside this manual. Never use a power washer to clean your eBike or the electronic components of your eBike.
- When storing your eBike ensure a sufficient SOC of all batteries.

3.2.2. Prohibited Use

You are not allowed to integrate our system in a non-compatible EPAC that was certified under EN 15494 or in a regular bicycle. It is a breach of MAHLE standards to manipulate the legal parameters (speed or power), to repair the battery or to reuse it for any other device or EPAC. It is a breach of MAHLE regulations to tamper our components, to change the software and firmware designed and approved by MAHLE, or to add electronics components which modify the maximum assist speed. If MAHLE terms are breached by non-compliance with the foregoing, MAHLE does not carry any legal responsibilities for damage caused to people or material.

The MAHLE system reserves the right to include functions which can analyze and record any kind of abnormal behavior such as too high a maximum speed or abnormal data communication, which could be caused by tampering the system. Any kind of manipulation shall immediately void all MAHLE warranty terms.

3.2.3. Operative mode (In the event of malfunction)

The system can operate in 3 different modes:

- Normal: Everything is OK.
Systems shows SOC and current assist level
- Alert: HMI line flashing ORANGE.
System does carry a level of malfunction, but your riding and assistance are not restricted.
- Warning: HMI line flashing RED.
Malfunction that limits the assistance. Ebike propulsion system is shut off. In this case, please reach out to the MAHLE SmartBike Systems Service or your local dealer

In case of any errors alerts (flashing ORANGE) or warnings (RED), the system sends the error or warning information through the Bluetooth® and ANT+ LEV compatible display. Please pair your smartphone and to check the error using the MAHLE APP My SmartBike or check the error using the Pulsar ONE display (will display the error code number).

There are 2 warning (RED) levels.

- System is ON but does not give assistance
- System starts automatically to SWITCH OFF

The list of error codes is attached at the end of this document.

3.3. Operation

3.3.1 Switching the system ON / OFF

Switching the system ON

Press the button of the head unit on to turn the system on. The LED of the Head Control Unit will light up and "hello" will be displayed. If everything is in order, the LED will display the battery charging status in white (SOC).

Switching the system OFF

To switch the system OFF, simply press and hold for 2 seconds the button of the Head Unit until the LED shows a Goodbye animation. The LED will turn OFF after the animation.

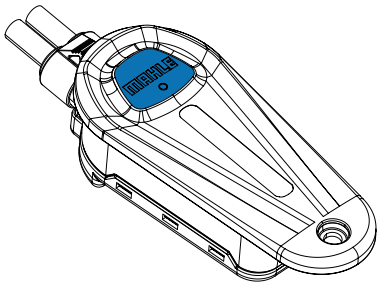

3.3.2 Automatic System Switching OFF

To save battery, when there is no speed and the smartphone with the APP is not connected, after 5 min, the system will switch OFF automatically by activation of the Power Safe Mode. At any time, the system can be switched ON again by following the normal procedure. This auto OFF process also occurs while charging process when the inner battery reaches 100% of SOC

3.3.3 Change the assist level

The assist levels can be changed through different methods:

Control the assist level using the HMI

To increase the assist level, briefly press the button on the Head Control Unit. The assist level of the eBike will increase. Once you reached the highest assist level, by pressing the button, the system will start the cycle again assist-free.

⚡ NOTICE

The system does remember the last selected assist level before the bike was switched off. If an error occurred before the bike was switched off, the assist level will be 0.

Control the assist level using e-Shifters

The system will allow to optionally add electronic shifters. The e-Shifters are based on 2 small micro buttons that can be installed on your handlebar. If these 2 remote buttons are connected to the Head Control unit, you can also control the assistance of the eBike using the micro buttons when the eBike system is switched ON.

Operation	Action
Left Short	Assist Down
Right Short	Assist Up
Left Hold	Reset Data
Right Hold	Turn ON/OFF Lights

⚡ NOTICE

The eBike manufacturer can configure or change the functionality of the Left and Right remote buttons. The functionality is set by default during the manufacturing process. For more information on this product, check the manual included in the e-Shifters or download it from the website: www.mahle-smartbike.com

Control the assist level using Pulsar ONE display

Your system can be used with the wireless Pulsar ONE display. The display has all information such as speed, current assist level, batteries SOC, time, distance, power, etc. The Pulsar ONE and your eBike communicates automatically through ANT+. The Pulsar ONE display comes with 3 buttons – a small one in the middle and two big ones on each side. With this accessory, you can also control the assistance of your eBike, by using the left and right buttons on your Pulsar ONE display, when the eBike is switched ON.

Operation	Action
Left Short	Assist Down
Right Short	Assist Up
Left Hold	Lights ON/OFF
Right Hold	Walk Assist

3.4. Switching the lights ON/OFF

If the lights on your eBike are connected to the X20 System you can control them using the HMI Head Control Unit. Please ensure that the used lights are compatible and a MAHLE compatible remote is used to activate or deactivate the light system too.

There are two main modes to control the lights:

- Automatic Mode: with the Ambient Light Sensor and according to environmental conditions the Head Unit will activate/deactivate the lights accordingly.
- Manual Mode: user can take control of activating the lights at any time, either via ANT+ LEV display or via e-Shifters when installed.



NOTICE

The eBike manufacturer could establish an additional automatic mode based on the switching ON/OFF of the eBike.

Switching the lights ON

Press the LEFT button of the e-Shifter long to switch the lights on. A "switching lights on" animation can be seen on the LED bar. If everything is ok the LED bar will turn back to the battery status.

Yellow color outer animation when switching ON the lights

Switching the lights OFF

Press the LEFT button of the e-Shifter long to switch the lights off again. A "switching lights off" animation can be seen on the LED bar. If everything is ok the LED bar will turn back to the battery status.

Yellow color inner animation when switching OFF the lights



NOTICE

The functionality of the LEFT and RIGHT button can be changed by the manufacturer. Please check the manual of your specific model for detailed information. Pressing the button for longer can control both walk assist and the lights. In accordance with particular regulations, the OEM can setup the status lights of the eBike upon system start.

3.5. Walk-assist Mode

To use the walk-assist mode, an additional remote e-Shifter accessory is required.

To activate the walk assist you need to hold the right button of the e-Shifter pressed down. Be aware that the bicycle manufacturer can always customize the functionality of the e-Shifters. The maximum speed during walk-assist is 6 km/h (Approximately 10 miles). If exceeded the walk assist will automatically shut off. The walk-assist will also shut off when you release the button.

The color of the current assist level will be displayed at 50% of the LED bar, when the walk mode is active. This will be visible while the mode is active.



NOTICE

Remember that the walk assist mode should only be used when walking the bike. The wheels need to be in contact with the ground to prevent injuries.

3.6. Information of the Head Unit - LED

The Head Control Unit permanently will inform you about the two most important parameters:

- SOC, State of Charge of the battery
- Active Assist Level

1

Control Button

2

Ambient light sensor

3

RGB Dynamic Line

4

Set screw

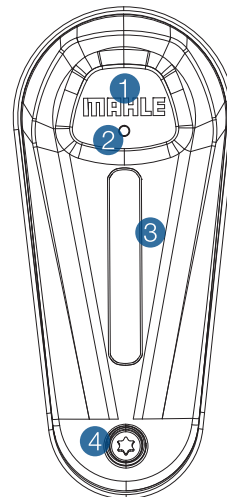

3.6.1. (SOC), State of Charge of the battery

The Head Unit will display the current battery status (SOC) through the visible length of the LED bar. 100% capacity, are represented through the full length of the line. As the battery is slowly draining, the illuminated length of the LED bar will decrease representing the decrease in capacity. The LED bar will always keep a minimum of one LED illuminated to be able to display the assist level used.

The LED line is generated by 7 LEDs that can create visual effects and animations. For the charging status and the length of the illuminated LED bar the relation is the following:

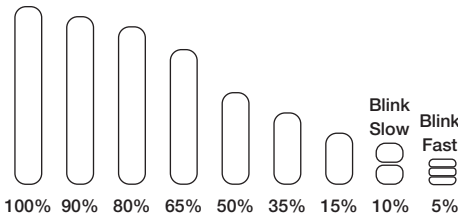

Illuminated LEDs	SOC
#7	94 - 100%
#6	82 - 93%
#5	70 - 81%
#4	56 - 69%
#3	36 - 55%
#2	16 - 35%
#1	0 - 15%
#1 (Blink slow)	0 - 10%
#1 (Blink fast)	0 - 5%

5-10% SOC - The system is limited to a maximum of 70% of its maximum nominal power output.

0-5% SOC - The system is limited to a maximum of 40% of its maximum nominal power output.

3.6.2. Current Assist Level

The system includes three different assist levels, which can be customized by the user, using the MAHLE APP My SmartBike. Each Assist level is represented by a different color as seen in the following table:

Level	Color	RGB
0 - No assist	White	#585858
1 - Minimum	Green	#00710F
2 - Medium	Clear Brown	#EE420F
3 - Max	Purple	#9416FF

3.6.3. Set the intensity of the LEDs

The main HMI button has a light sensor integrated. Using this sensor, the HMI automatically will increase or decrease the intensity of the LED line, to improve the visibility of the information.

3.6.4. Other Information displayed by the HMI

The battery status and the assist level are displayed through the color and the length of the LED bar.

Depending on the status of the eBike system, additional information can be communicated

Switching the bike OFF

A white color appears after briefly pressing the button down.

Switching the bike ON

A white color appears after briefly pressing the button down.

Charging Status while charge

Cyan color appears with a pulsating effect.

Battery Charged

Permanent green LED bar.

BLE connected or disconnected

Blue color appears.

Lights switched ON or OFF

Yellow outer color appears when lights are switched ON
Lights ON << >>

Yellow inner color appears when lights are switched OFF
Lights OFF >> <<

Error

Flashing red light when the system is having an active error. Please switch off the system and ensure the error is solved.

Error  Warning 

WARNING

Flashing orange light when the system is having an active warning alert. The use of the system is not restricted but attention should be paid to the warning.

Updating in progress

Flashing pink light when software update is performed on the system. 

Walk assist mode activated

The color of the current assist level will be displayed at 50% of the LED bar, when the walk mode is active. This will be visible while the mode is active.

3.7. Operation with the Charger

3.7.1. X20 My SmartBike Active Charger

X20 My SmartBike Active Charger includes CAN BUS communication and a Micro-USB interface to perform updates on full eBike System. This charger is compatible with all X20 MAHLE inner batteries and Range Extenders.

The Active Charger allows fast charging with up to 4A, using the CAN Communication port to identify the battery model and current charging status, supplying the appropriated charging current depending on the current SOC.

It does include 2 LED bars to inform about the charging mode and status, projecting a retro-illumination against any surface i.e., the wall or the floor.

As an optional component there is a wall mount available to place the Active Charger on the wall, keeping the wiring organized when not connected to the eBike or while charging.

3.7.2. Charging Process

To ensure that it is being charged correctly, please follow these instructions

1. Connect the charger to the power outlet.

LED of the charger will display a steady WHITE light.

Make sure there is no cable connected to the micro-USB port before charging.



2. Connect the charger to the charging port on the eBike

LED of the charger and the HMI of the bike will turn CYAN.

Breathing effect: From high to low frequency by increasing level of charge.

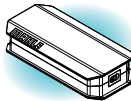

3. Charge process finished

Once charging is completed, the LED of the HMI will be a steady GREEN light.

Disconnect the charger from the power source before disconnecting from the eBike.



Error during charging process

If a critical error occurs while charging, the LED of the charger will flash in RED.

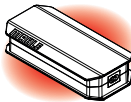

3.8. Updating Process

It is possible to update the system by using the micro-USB port of the smart charger. To perform an update, you need to connect the charger to your computer and transfer the updating files to the charger. Please follow this process:

3.8.1. Uploading files to the Active Charger

1. Disconnect the charger of the Power outlet

No LED will be operating.



2. Connect the charger to your computer using micro-USB port

LED of the charger and the HMI will turn to a PURE BLUE light.

Copy the unzipped update files (update_MUT.bin) to the new Drive Unit (MAHLE_UTOOL) which will appear on your computer and safety remove the new drive on your computer.

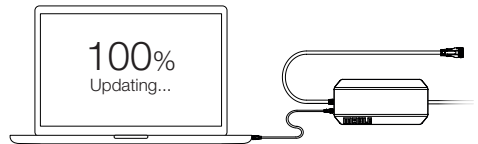
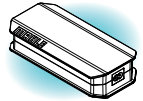

3. Disconnect the charger of your computer

No LED will be operating.



Error while uploading

If an error occurred during the uploading process, the LED of the charger will turn to a steady RED light for 10 seconds. After that, the charger goes back to normal operation.

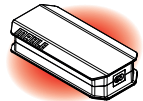

3.8.2. Updating eBike system

Once the files are into the Active Charger you can update your system. For updating a second eBike you will need to repeat the full updating process.

1. Connect the charger of the Power outlet

LED of the charger will display a steady WHITE light.

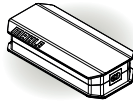

2. Connect the Charger to the eBike

Connect the charger to the eBike as you would connect it for a normal charging process. The LED of the charger will constantly flash in PURPLE while the update is being performed.

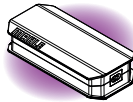

3. Update Completed

Once the update process is finished the LED of the charger will turn to a steady GREEN light for 10 seconds. After that, the charger goes back to normal operation.

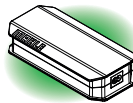

Error while uploading

If an error occurred during the updating process, the LED of the charger will turn to a steady RED light for 10 seconds. After that, the charger goes back to normal operation.

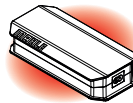

3.9. Battery Use

MAHLE SmartBike Systems does use high quality cells for both, inner- and external batteries. We do this to get the most out of our minimalistic battery following our LIGHT, SPORT, SMART premise. To ensure a long battery life, please follow the guidelines below:

- One important factor is the number of charging cycles – every time you charge the battery it will degrade.
- If you store the battery, try to keep the battery status between 30% and 60%.
- Don't leave your bike exposed to the sun for extended periods
- Don't expose the battery to cold temperatures for extended periods of time.
- When starting an activity, do not use the maximum assist right away – your battery needs to reach its operating temperature first
- Do not store your battery 100% charged for long periods and remember to drain it frequently
- When storing your bike for longer periods of time ensure the temperature stays within 10-20 degrees.



NOTICE

Remember a battery is considered as a consumable good.

4. Accessories

Your X20 System is compatible with various accessories. Your eBike might already be initially equipped with some additional accessories from brand side. If your eBike is not equipped yet with additional components, the following accessories can always be added to the X20 System:

- Pulsar ONE display
- e-Shifters
- Range Extender

4.1. Pulsar ONE display

Pulsar ONE is an ANT+ eBike computer developed by MAHLE specially designed to be used with ANT+ compatible MAHLE systems (X35+ or X20). The Pulsar ONE connects wireless to the eBike system using the ANT+ LEV communication protocol (Light Electronic Vehicle – all new MAHLE systems are fully compatible).

The 2.1" wide screen lets you see vital information about your eBike system such as battery level, assistance level, light system status, range and errors, as well as basic riding information such as speed or time. This information is complemented by additional essential data for any rider, such as average speed, maximum speed, ride time, ride distance, eBike odometer, heart rate, cadence, etc.

Pulsar ONE display

SKU: 330 100 000 00 000

Includes display, Screen protector, battery CR2032 and user manual.

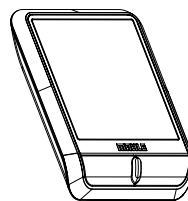

- 2.1" black & white LCD with 3 buttons
- Wireless connectivity by ANT+
- Waterproofness IP67
- Battery type CR2032 (Included)
- Certifications (CE, FCC, IC, KCC, Teleg and RCM)
ANT+ LEV, HR, CAD, PWR, CTF
- Dimensions (57.7 mm x 41.1 mm)
- Weight 28 grs (with CR2032)



NOTICE

You can use the buttons of the display to control the assist levels and the lights. Further information on this product can be found in the user manual.

4.1.1. Pulsar ONE holders

There are two different optional holders to place the display in 4 different positions. It is also possible to use other GARMIN compatible device holders. To ensure a safe installation, please ensure you are using a compatible holder with your Pulsar ONE display:

Pulsar ONE Sport holder
SKU: 330 100 000 01 000

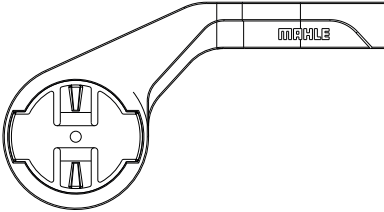

Pulsar ONE Urban holder
SKU: 330 100 000 02 000

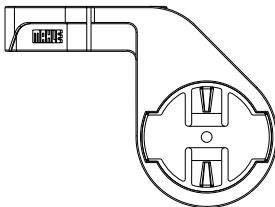

4.2. e-Shifters

e-Shifters is a set of 2 small optional buttons connected to the Head Unit which allow to control the functions of the MAHLE SmartBike System directly from the handlebar (assist level, lights, etc.). The minimalist design allows them to be installed independently from the handlebar used (drop- or flat bar).

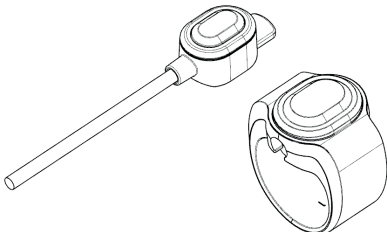

By pressing the e-Shifters, whether briefly or for longer, different commands are sent to the system. A maximum of 2 e-Shifters per eBike can be installed (left and right).

The e-Shifters give haptic feedback to the rider by vibrating (under patent) whenever the status of the system is changed to not draw the attention away from riding.

Using the e-Shifters can help to increase the safety while riding by avoiding removing the hand from the handlebar. Additionally, the vibration of e-Shifter buttons deliver additional information to the rider when the APP or the eBike system changes the status or reports an alert.

To upgrade e-Shifters to your X20 equipped bike, please get in touch with your local dealer to ensure a correct installation and connection to the X20 System. The following configurations are available:

e-Shifter 720
SKU: 350 100 000 00 200

Giftbox + Y-Joint + 2 e-Shifters with 720mm length wire + 2 Silicon Bands + Manual

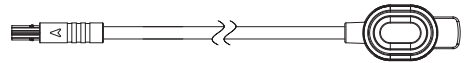

e-Shifter 970
SKU: 350 100 000 00 300

Giftbox + Y-Joint + 2 e-Shifter with 970mm length wire + 2 Silicon Bands + Manual

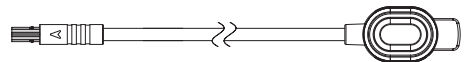

4.2.1. e-Shifters Installation

The e-Shifters allow to be installed in various ways and areas of the handlebars. The included e-Shifter rubber hoods can be used to install the e-Shifters in every possible area of the handlebar. Without the rubber hoods, the e-Shifters can be installed under the bar tape on drop bars.

Curved - Road and Gravel

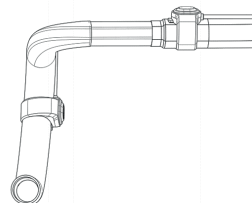

The ergonomic design of e-Shifters and rubber hoods allows the installation in various areas of the handlebar.

Flat – Mtb and Commuter

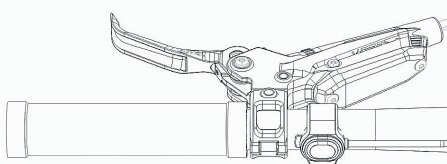

The ergonomic design of the e-Shifter and rubber hoods allows them to be placed in a perfect, easy to reach position.

4.3. e185 - Range Extender

The e185 Range Extender is our latest generation of external batteries and can always be added to the X20 System. The e185 is working as an independent battery supplying its power directly to the motor without any interference of the main battery. With the new My SmartBike APP, it is now possible to customize the power consumption of your eBike between the main and the external battery.

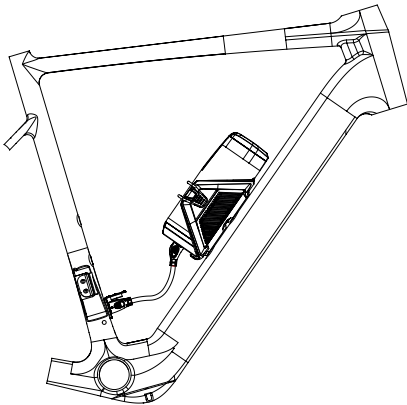

The Range Extender carries 171Wh in addition and allows you to increase your range drastically, while only adding 1Kg of extra weight to the system. This will upgrade your total capacity by 77% when added to the iX250 battery and 53% when added to the iX350 battery. The new designed holder for the e185 Range Extender follows the design, size and mounting points of a regular bottle cage and can therefore also be used to carry a regular bottle when the Range Extender is not used.

4.3.1. Range Extender Pack Components

The Range Extender e185 pack includes:

Battery Pack e185
SKU: 41010400000000

- Weight: 1.100 grs.
- Waterproofness IP67
- Capacity: 177Wh

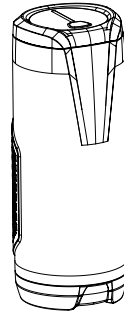

Holder
SKU: 24010414300000

- Compatible with standard water bottles
- 4 x 15mm slotted holes (64mm standard distance)
- Weight: 46 grs.

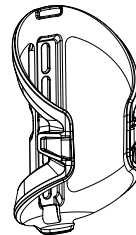

Rubber (to lock the holder)
SKU: 24010414301000

