



SAUNABOX

OWNERS MANUAL

SAUNABOX™

# SaunaBox GO Instructions

## ABOUT HEAT THERAPY

For centuries, heat therapy has stood out as a profound and effective wellness practice for detoxification and rejuvenation. Embracing the warmth of steam saunas elevates the body's temperature, boosting circulation to essential organs and the skin. This process ignites the natural detoxification and cellular repair pathways within the body. The unique advantage of steam sauna sessions lies in their ability to promote intensive sweating and healing without the physical exertion required by exercise, allowing your energy to be fully directed toward the body's natural restoration processes.

## THE SAUNABOX ADVANTAGE



### RELAXATION + STRESS RELIEF

Calming environment that helps reduce stress and promote relaxation. The heat and steam combination can help soothe both the body and mind, aiding in stress relief and overall well-being.



### MUSCLE RECOVERY

The heat and moisture promotes vasodilation, which increases blood flow to the muscles. This improved circulation aids in muscle recovery, reduce muscle soreness, and facilitate the healing process after workouts or sports injuries



### RESPIRATORY HEALTH

The humid environment helps soothe and open up the airways, making it beneficial for individuals with respiratory conditions like sinus congestion, allergies, or bronchitis.



### IMPROVED SLEEP

Promotes a sense of calmness, and prepares the body for a restful sleep. Sauna sessions in your evening routine can aid in falling asleep faster and experiencing deeper, more rejuvenating sleep.



### IMPROVED CIRCULATION

The heat from a steam sauna helps dilate blood vessels, enhancing circulation throughout the body. This increased flow can have a positive impact on cardiovascular health, nutrient delivery, and waste removal.



### DETOXIFICATION

Sweating inside the sauna helps flush out toxins and impurities from the body, promoting a healthier and cleansed system.

## WHEN TO USE THE SAUNABOX

- **In The Evening Or Before Sleep:** For maintaining deep sleep, it's essential that your body temperature drops by 1-3 degrees. Heat exposure at night aids in initiating that cooling process.
- **Post Workout:** Using a steam sauna post-exercise can aid in muscle recovery, relieve soreness, and accelerate the elimination of metabolic waste, making it an excellent addition to your fitness regimen.
- **For Respiratory Benefits:** Engaging in steam sauna therapy when you feel congested or have respiratory issues can help clear your airways and improve your breathing.
- **Anytime You Need To De-Stress & Relax:** Let the heat ease your body and mind.

SAUNABOX'S STEAM SAUNA COMBINES THE TIMELESS BENEFITS OF TRADITIONAL STEAM THERAPY WITH MODERN CONVENIENCE, OFFERING YOU A SANCTUARY OF RELAXATION AND DETOXIFICATION IN THE COMFORT OF YOUR HOME.

EXPERIENCE THE ENVELOPING WARMTH AND MOISTURE OF A STEAM SAUNA TO UNLOCK A HEALTHIER, MORE REJUVENATED YOU.

# TABLE OF CONTENTS

IMPORTANT SAFETY INSTRUCTIONS	04
READ BEFORE USE	10
GETTING STARTED	14
CLEANING & MAINTENANCE	21
HOW TO USE ESSENTIAL OILS	24
WARRANTY INFORMATION	25
TECHNICAL PARAMETERS	28
SAFETY IN FRENCH	29
SAFETY IN SPANISH	32

# IMPORTANT SAFETY INSTRUCTIONS

## + DANGERS/WARNINGS

**CONSULT A DOCTOR BEFORE USE. THIS IS NOT A MEDICAL DEVICE. IF YOU HAVE ANY OF THE CONDITIONS BELOW, USE OF THE SAUNA IS NOT RECOMMENDED WITHOUT YOUR DOCTOR'S APPROVAL:**

- You have skin diseases, burns or reddening.

---
- You have splanchnic diseases.

---
- You require a heart defibrillator or use any other implantable devices.

---
- You have a heart disease or illness.

---
- You have broken bones.

---
- You have malignancy.

---
- You feel nauseous, have a headache or other symptoms.

---
- You have just had surgery.

---
- You have osteoporosis.

---
- You suffer from abnormal blood pressure.

---
- You are currently pregnant or breastfeeding.

---
- You have anhidrosis.

---
- You have cancer or other malignant conditions.

---
- You have any metal or other body implants, including breast implants.

---
- You have mental illness.

# IMPORTANT SAFETY INSTRUCTIONS

## + DANGERS/WARNINGS

WHEN USING ELECTRICAL APPLIANCES, BASIC SAFETY PRECAUTIONS SHOULD ALWAYS BE FOLLOWED TO REDUCE THE RISK OF FIRE, ELECTRIC SHOCK, AND/OR INJURY TO PERSONS. MISUSE OR FAILURE TO FOLLOW THESE WARNINGS AND INSTRUCTIONS MAY CAUSE OVER-HEATING, FIRE, PERSONAL INJURY AND/OR PROPERTY DAMAGE:

- Be sure to read all instructions carefully before using this product.
- 
- The SmartSteam unit may become very hot. Place on a heat-resistant surface.
- 
- **US & CA province customers:** The sauna is designed to be plugged into a standard U.S. Type B (NEMA 5), 110-120V electrical outlet. Be sure that this heated product is used only on an AC supply circuit of the proper voltage. Do not use with an extension cord. Do not use with generators, power converters or inverters. Use of the sauna in other countries with electrical transformers is at your own risk.
- 
- **UK / EU/ UK / & Other Non US province customers:** The sauna is designed to be plugged into 110-120V electrical outlet. Do not use with an extension cord. Do not use with generators, power converters or inverters. Use of the sauna in other countries with electrical transformers is at your own risk.

# IMPORTANT SAFETY INSTRUCTIONS

## + DANGERS/WARNINGS

- Examine the product, cord, & controller before each use for signs of wear or damage. If improper operation, wear or damage is observed, discontinue its use immediately, unplug it, and email SAUNABOX Customer Care – [support@saunabox.com](mailto:support@saunabox.com)

---

- Keep all dogs, cats, and other pets away from this product. This is an electrical appliance that they can damage or be injured by.

---

- Do not use this product with an infant, child, incapacitated or immobile person, paraplegic or quadriplegic, a diabetic, anyone insensitive to heat, or anyone who cannot clearly understand the instructions and/or operate the controls.

---

- Do not use in conjunction with another electrically heated product.

---

- Do not tuck in, pinch, flex, or expose the wired area of the steam unit. Do not tuck in the supply cord or control in a sofa or other furniture. All portions of this product should be visible at all times.

---

- Controller is not waterproof. Do not immerse in water or other liquids. Keep the controller away from drafty areas that may become damp or wet such as an open window.

---

- Allow to cool before storing and do not crease by placing items on top of it. Store in the original packaging, in a cool, dark, dry place.

# IMPORTANT SAFETY INSTRUCTIONS

## + DANGERS/WARNINGS

- Metal jewelry or other products may get hot when using the sauna.

---
- Do not use this heated product with analgesic creams.

---
- Turn off and unplug this heated product when not in use.

---
- Do not use corrosive cleaning products to clean the kit.

---
- An appliance should never be left unattended when plugged in. Unplug from outlet when not in use and before putting on or taking off parts.

---
- Close supervision is required when this appliance is used by, on, or near children, invalids, or disabled persons. Not intended for use by children without doctor's approval or supervision.

---
- Never operate this appliance if it has a damaged cord or plug, if it is not working properly, if it has been dropped or damaged, or dropped into water.

---
- Do not carry this appliance by supply cord or use cord as a handle.

---
- Keep the cord away from heated surfaces and water.

---
- Speak with a doctor before use if you are unsure if sauna usage is safe for you.

# IMPORTANT SAFETY INSTRUCTIONS

## + DANGERS/WARNINGS

- Never open the SmartSteam Unit's lid while it is in use.
  - Turn off and unplug the steam unit and allow the water to cool before opening. Remove the lid slowly.

---
- Before turning on the SmartSteam Unit, ensure the lid is firmly twisted into the grooves on top of the steamer.
  - Do this by pressing down and turning the lid clockwise into the grooves

---
- Always ensure there are no blockages or folds in the tubing that would prevent airflow from the SmartSteam unit while it is in use.

---
- The user will be wet with sweat and moisture after use. Depending on location and duration of use, minor humidity may also condensate underneath the sauna. It is recommended to use on a water-resistant surface and dry off moisture after use to prevent damages from moisture to any surfaces.



(02)

READ  
BEFORE  
USE



## READ BEFORE USING STEAMER

- (01) **PLEASE USE** caution when steamer is in use as the water and steam are very hot.
- 
- (02) **BEFORE turning the steamer on**, secure the lid properly by firmly pressing the lid down into the grooves on top of this steamer and rotating the lid clockwise. Ensure it is firmly locked in place before turning the steamer on. Steam should not be escaping from the lid.
- 
- (03) **BEFORE USE**, ensure there are no clogs or folds in the tubing attached to the steamer that could cause built up pressure in the steamer.
- 
- (04) **DO NOT** unlock or open the lid while the steamer is in use.
- 
- (05) **ALWAYS** ensure the steamer is off and unplugged before opening the lid.
- 
- (06) **DO NOT** use the steam unit for more than 1 hour. Turn off and unplug the steamer before opening the lid to add more water if you want to use it continuously.
- 
- (07) **DO NOT** fill the steamer past the water level indication line.
- 
- (08) **AFTER EACH USE**, empty any water buildup in the steam dispenser located inside the sauna after each use. Water inside the dispenser can cause pressure buildup.
- 
- (09) **CLEAN** the surface of the heating element after each use if it becomes dirty. Depending on water being used, mineral deposits may form on the bottom of the steamer after several uses.

# IMPORTANT READ BEFORE USE

## BEFORE USE PLEASE

- REVIEW ENTIRE MANUAL
- 

- REVIEW SAFETY INSTRUCTIONS
- 

- Inspect the surface and inside of the sauna for wear and tear, the SmartSteam unit and cord for fraying, and do not use if either is present.
- 

- DO NOT PUT essential oils inside the SmartSteam unit as it will cause damage. Please refer to page 18 for essential oil application.
- 

## WHERE DO I USE IT?

- The SaunaBox can be used both indoors or outdoors. If you use it outdoors, we recommend having an appropriate cover such as a canopy, balcony, tarp, etc.
- 

- The SaunaBox is NOT WEATHERPROOF - Leaving the SaunaBox outdoors for long a period of time can cause cosmetic damage to the sauna.
- 

## WHAT DO I WEAR?

- Clothing is optional in the sauna. The SaunaBox team recommends nude with a bath towel to absorb sweat.
- 

- If you choose to wear clothing, we recommend wearing either something comfortable made of cotton or swim attire.
- 

- It is recommended to bring the SaunaBox hand towel inside the sauna to absorb sweat.

# IMPORTANT READ BEFORE USE

## DURING USE

- **IMPORTANT:** To begin, start at level 1-5 and slowly increase to level 6 or 7. Level 7 should **ONLY** be used if sweating cannot be achieved on lower levels.

---

- Do not exceed 60 minutes inside the sauna.

---

- The controller is not waterproof - do not bring inside the sauna.

---

- **DO NOT** open the lid while the steamer is in operation and always allow the steamer to cool before cleaning or touching.

---

- **DO NOT** touch the SmartSteam unit or the steam dispenser during or after use. They are extremely hot.

---

- **NEVER** move the steamer while it contains hot liquids.

## AFTER USE

- Please refer to page 12 for detailed maintenance instructions.

---

- Keep unit unplugged at all times when not in use and before cleaning.

(03)

# GETTING STARTED

FOR VIDEO TUTORIAL, PLEASE  
SCAN VIA MOBILE PHONE  
(RECOMMENDED):



# TENT SETUP

PLEASE READ THE INSTRUCTIONS BEFORE ASSEMBLY.

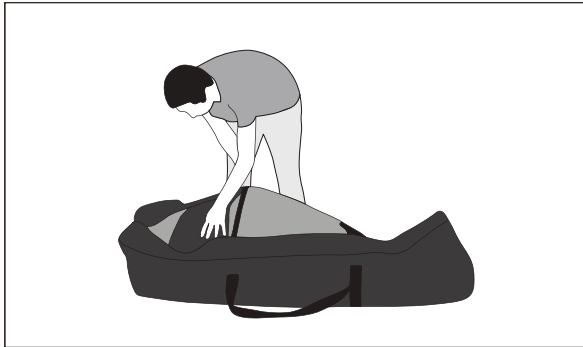

**(01)**

Remove the tent from the carrying case. Open the tent with the top facing upward and lay the tent flat on the ground.

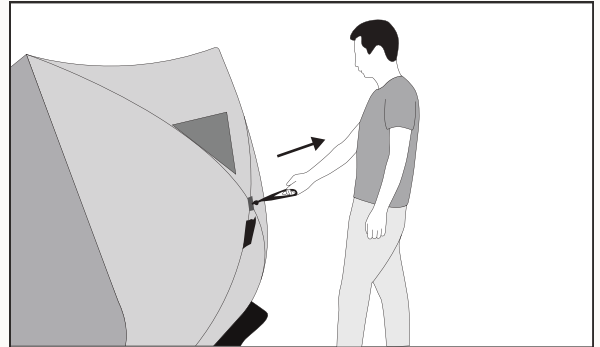

**(02)**

Pull the tent's handle outward on each side until all 4 sides pop out.

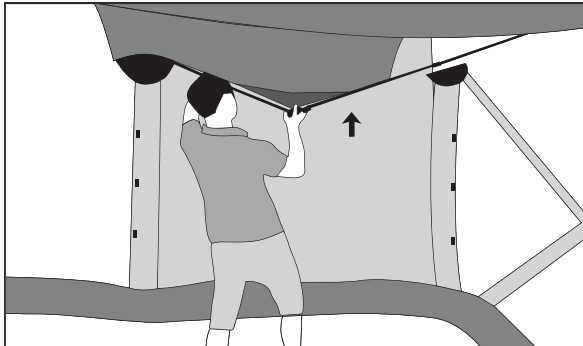

**(03)**

Push the center of the roof up until it pops out.

# TENT STORAGE

PLEASE READ THE INSTRUCTION BEFORE STORING AWAY

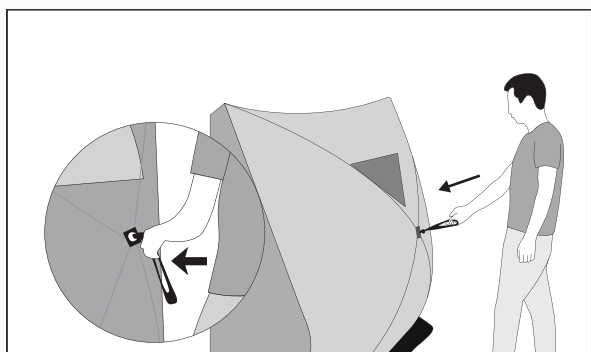

**(01)**  
On all walls, push the center hub in to collapse tent. Then, push the roof hub down.

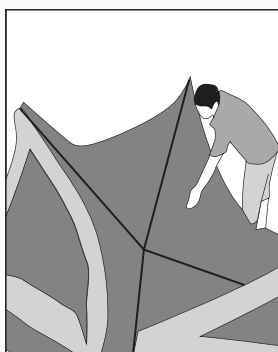

**(02)**  
Gather all corners of tent and fold together.

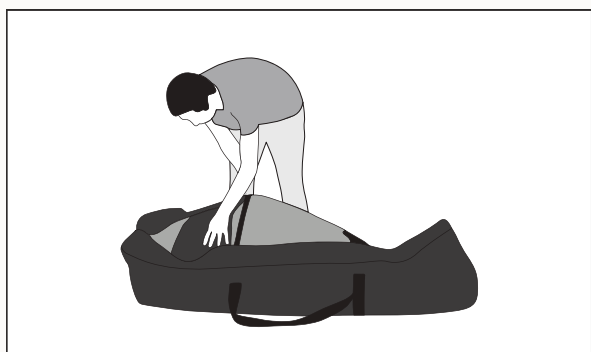
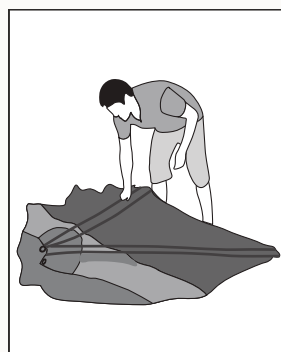

**(03)**  
Tie down straps and insert the tent into bag.

# STEAMER SETUP

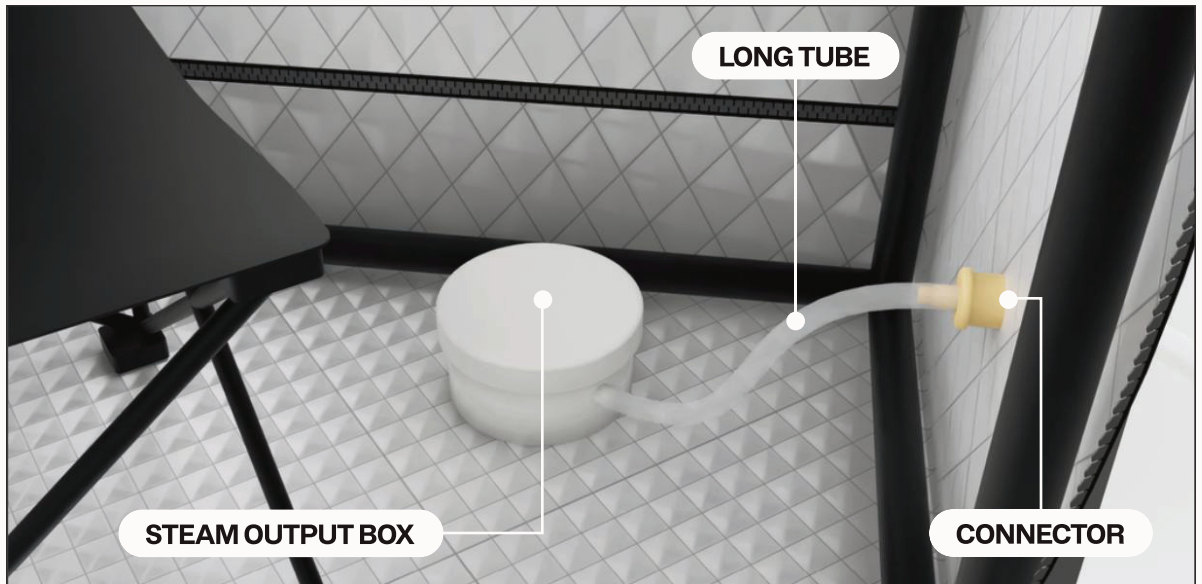

- (01) **Next assemble the steam output box (refer to image above):** Attach the LONGER tube to the steam output box. Then, screw the connector into the tent. Attach the tube to the connector.

---

- (02) **Assemble the SmartSteam unit:** Attach the SHORTER tube to the output hole on the lid. Then, attach the end of the tube to the SaunaBox connector. Once fully setup and you are ready to use the SaunaBox, **plug the SmartSteam unit into a 110V outlet.**

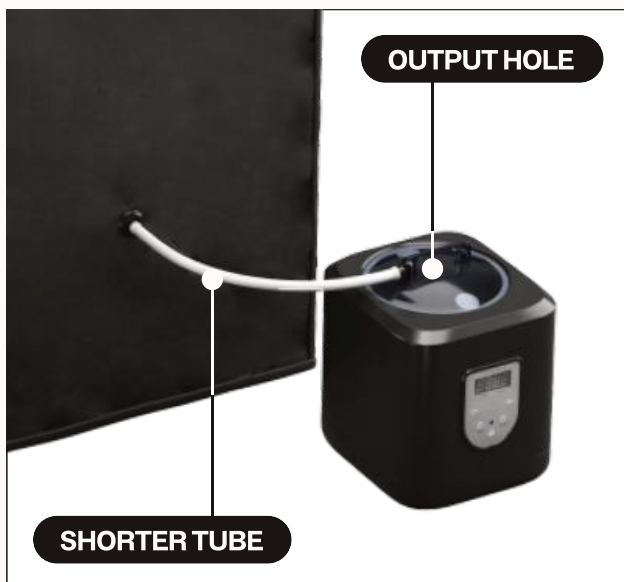



# SETTING UP (CONT.)

## GETTING STARTED

- (03) **Insert SweatLock Floor Mat:** With the logo facing upwards and nearest to the door opening, slide the SweatLock Mat in. It should fit snug on the bottom of the sauna.
- 
- (04) **Assemble Chair**
- 
- (05) **Remove the lid** by turning it counterclockwise.
- 
- (06) **Fill up to 3.5 Liters** of water inside the stainless steel heating chamber. We recommend distilled water to ensure the purest water is being consumed in the sauna. Do not fill past the line marked in the stainless steel chamber. **DO NOT** put essential oils into the SmartSteam Unit's chamber (Refer to page 18 for essential oil use)
- 
- (07) **BEFORE** turning the steamer on, secure the lid properly by firmly pressing the lid down into the grooves on top of the steamer and rotating the lid clockwise. Ensure it is firmly locked in place before turning the steamer on. Steam should not be escaping from the lid.
- 
- (08) **Turn on SmartSteam** unit by pressing the on/off button.
- 
- (09) **Adjust Heat Level:** To begin, start at level 1-7 and slowly increase to level 12 or 13. Level 13 should **ONLY** be used if sweating cannot be achieved on lower levels.
- 
- (10) **Adjust Duration:** We recommend starting at 20-45min. You can adjust the time and heat at any time by pressing the "+" or "-" buttons
- 
- (11) Make sure the door is fully shut and zippers are closed.
- 
- (12) **Please allow 10-15 minutes** for the SaunaBox to heat up and start producing steam.
- 
- (13) Once the inside of the SaunaBox is at your desired temperature, **open the door and sit inside to enjoy endless relaxation and rejuvenation.**

# SETTING UP (CONT.)

## GETTING STARTED

**DO NOT TOUCH  
(EXTREMELY HOT)**



- Once you have completed your session, **exit the sauna.**

---

- **Always unplug** the SmartSteam unit from the wall after use.

---

- **For sanitary reasons**, we recommend you clean the sauna between each session. (Refer to next page for cleaning instructions)

---

- **CAUTION:** After use, the SmartSteam unit and the steam output box will be extremely hot.

---

- **DO NOT** unlock or open the lid while the steamer is in use or at least 45 min after use.

---

- Leave the SaunaBox door open to air out completely.

---

- **After the sauna has cooled**, ensure the steam output box inside of the sauna is emptied and not filled with water before your next use.

(04)

# MAINTAINING YOUR SAUNA Cleaning Your Kit

# MAINTAINING YOUR SAUNA

## CLEANING YOUR KIT

We suggest cleaning the sauna and steam unit in between each use to keep your kit in the best condition.

### SUGGESTED CLEANING TIPS:

- First, allow the steam generator to cool down completely before cleaning the inner compartment.

---

- To keep the steamer in optimal condition, clean the inner stainless steel chamber after each use.

---

- Please wipe the steam generator with a wet cloth in order to keep it clean.

---

- If user does not use distilled water, mineral deposits may appear at the bottom of the chamber in the form of white/off-white crusty buildup.

---

- Use a cloth or towel to absorb any sweat or water vapor left behind inside the tent to prevent liquid buildup.

---

- Only use a non-toxic gentle soap or a non-toxic cleaning wipe on the kit.

---

- Do not use corrosive cleaner or any toxic chemicals that could pose harm when the kit is in use.

---

- Machine wash the absorbent floor mat (or towel being used as floor mat) after each use.

---

- Leave tent door open to allow air into the sauna after use.

---

- Depending on your local climate and if your chair was not covered while in use, leave the chair outside of the tent to air out.

# MAINTAINING YOUR SAUNA

## CLEANING YOUR KIT

### STORAGE AND USAGE:

- Allow time for the steam unit to cool after use, ensuring it is off before unplugging from power.

---

- Ensure the sauna is completely dry before storing.

---

- Store in a cool, dry place.

---

- The sauna tent is not designed to be left outdoors with no coverage.

---

- Do not machine wash or dry clean the sauna tent - only the absorbent mat and towel provided are intended for machine wash.

---

- Do not place any objects on top of the sauna tent or steamer.

---

- Leave unplugged when not in use and ensure no electronics are near water.

---

# HOW TO USE ESSENTIAL OILS

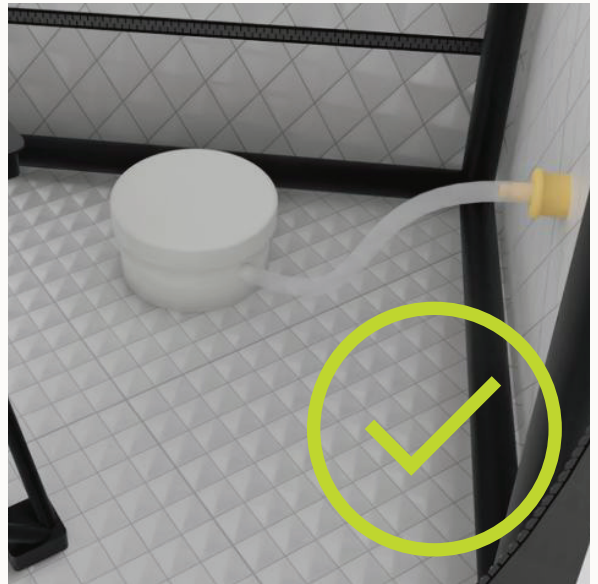

- **Open up the top** of the **Steam Output Dispenser** found inside of the Sauna Box. **Do not** put essential oils in the stainless steel SmartSteam chamber itself. This is harmful to the steamer & lid.

---

- **CAUTION:** Do not touch dispenser if sauna is in use or after sauna use. **EXTREMELY HOT.**

---

- **Place 4-10 drops** of an essential oil of your preference inside the steam dispenser.

---

- Clean out steam dispenser after each use when the unit has cooled and ensure no water remains before the next session.

---

Enjoy!

(05)

# WARRANTY INFORMATION

# WARRANTY INFORMATION

**AT SAUNABOX, WE ARE COMMITTED TO ENSURING THE HIGHEST QUALITY AND CUSTOMER SATISFACTION WITH OUR PRODUCTS. WE STAND BEHIND THE CRAFTSMANSHIP AND RELIABILITY OF OUR PORTABLE STEAM SAUNA, THE SAUNABOX, AND OFFER A COMPREHENSIVE 2-YEAR WARRANTY FROM THE DATE OF PURCHASE. PLEASE READ THE FOLLOWING WARRANTY POLICY CAREFULLY TO UNDERSTAND YOUR RIGHTS AND RESPONSIBILITIES.**

**Warranty Coverage:** Our warranty covers any manufacturing defects, technical malfunctions, or minor wear from aging for the following components of the SaunaBox: the SmartSteam unit, heat-insulated frame cover, fiberglass frame, bottom sweat mat, and chair.

**Warranty Exclusions:** The warranty will be void if the customer does not strictly follow the instructional manual provided with the SaunaBox. It is crucial to thoroughly read and follow the instruction manual to ensure proper usage and maintenance. Failure to do so may prevent the customer from availing the 2-year warranty.

The warranty will also be void if any of the above-mentioned components are broken or damaged due to mishandling, improper usage, or failure to read and adhere to the full instruction manual.

**Warranty Claims:** To make a warranty claim, the customer must provide proof of purchase and notify SaunaBox within the warranty period. Please contact our customer support team through [support@saunabox.com](mailto:support@saunabox.com) to initiate the warranty claim process.



# WARRANTY INFORMATION

If a covered component is found to have a manufacturing defect or technical malfunction, we will either repair or replace the affected part, at our discretion, free of charge.

**Limitations:** Please note that our warranty does not cover damages resulting from normal wear and tear, misuse, accidental damage, alterations, unauthorized repairs, or any damages caused by factors beyond our control. Our warranty is non-transferable and applies only to the original purchaser of the SaunaBox.

**DISCLAIMER: SAUNABOX SHALL NOT BE HELD LIABLE FOR ANY INDIRECT, INCIDENTAL, OR CONSEQUENTIAL DAMAGES ARISING FROM THE USE OR INABILITY TO USE THE SAUNABOX, EVEN IF ADVISED OF THE POSSIBILITY OF SUCH DAMAGES.**

# TECHNICAL SPECS

**Heat Levels:** 1-13

---

**Time Settings:** 0-60 minutes

---

**Control:** SmartSteam Unit & Handheld Controller

---

**SmartSteam Capacity:** 3.6L

---

**Voltage:** 110V

---

**Wattage:** 1600 Watts 50/60Hz

---

**Warranty:** 2-Year Warranty

---

**Size:** 49 x 49 x 49 in

---

**DISCLAIMER: REMEMBER, ALWAYS SPEAK WITH A HEALTHCARE PROFESSIONAL BEFORE INCORPORATING SAUNAS INTO YOUR ROUTINE, ESPECIALLY IF YOU HAVE ANY UNDERLYING HEALTH CONDITIONS. THIS IS NOT A MEDICAL DEVICE AND IS NOT INTENDED TO BE USED AS ONE.**

# INSTRUCTIONS DE SÉCURITÉ IMPORTANTES

## + DANGERS / AVERTISSEMENTS

**CONSULTEZ UN MÉDECIN AVANT UTILISATION. CE N'EST PAS UN DISPOSITIF MÉDICAL. SI VOUS PRÉSENTEZ L'UN DES TROUBLES CI-DESSOUS, L'UTILISATION DU SAUNA N'EST PAS RECOMMANDÉE SANS L'APPROBATION DE VOTRE MÉDECIN:**

- Vous avez des maladies de la peau, des brûlures ou des rougeurs.
- Vous avez des maladies spléniques.
- Vous avez besoin d'un défibrillateur cardiaque ou utilisez tout autre dispositif implantable.
- Vous avez une maladie ou une affection cardiaque.
- Vous avez des os cassés.
- Vous avez une malignité.
- Vous vous sentez nauséux, avez mal à la tête ou d'autres symptômes.
- Vous venez de subir une intervention chirurgicale.
- Vous avez de l'ostéoporose.
- Vous souffrez d'une pression artérielle anormale.
- Vous êtes actuellement enceinte ou allaitez.
- Vous avez de l'anhydrose.
- Vous avez un cancer ou d'autres affections malignes.
- Vous avez des implants métalliques ou autres, y compris des implants mammaires.
- Vous avez une maladie mentale.

**LORS DE L'UTILISATION D'APPAREILS ÉLECTRIQUES, IL EST TOUJOURS NÉCESSAIRE DE SUIVRE DES PRÉCAUTIONS ÉLÉMENTAIRES DE SÉCURITÉ AFIN DE RÉDUIRE LES RISQUES D'INCENDIE, DE CHOC ÉLECTRIQUE ET/OU DE BLESSURES. UNE MAUVAISE UTILISATION OU LE NON-RESPECT DE CES AVERTISSEMENTS ET INSTRUCTIONS PEUT ENTRAÎNER UNE SURCHAUFFE, UN INCENDIE, DES BLESSURES CORPORELLES ET/OU DES DOMMAGES MATÉRIELS :**

- Assurez-vous de lire attentivement toutes les instructions avant d'utiliser ce produit.
- L'unité SmartSteam peut devenir très chaude. Placez-la sur une surface résistante à la chaleur.
- Clients des États-Unis et du Canada : Le sauna est conçu pour être branché sur une prise électrique américaine standard de type B (NEMA 5), 110-120 V. Assurez-vous que ce produit chauffant est utilisé uniquement sur un circuit d'alimentation en courant alternatif de la tension appropriée. N'utilisez pas avec une rallonge. N'utilisez pas avec des générateurs, des convertisseurs de courant ou des onduleurs. L'utilisation du sauna dans d'autres pays avec des transformateurs électriques se fait à vos propres risques.
- Clients du Royaume-Uni, de l'Union européenne et d'autres pays non américains : Le sauna est conçu pour être branché sur une prise électrique de 110-120 V. N'utilisez pas avec une rallonge. N'utilisez pas avec des générateurs, des convertisseurs de courant ou des onduleurs. L'utilisation du sauna dans d'autres pays avec des transformateurs électriques se fait à vos propres risques.

- Examiner le produit, le cordon et le contrôleur avant chaque utilisation pour détecter des signes d'usure ou de dommage.
- En cas de mauvais fonctionnement, d'usure ou de dommage observé, cesser immédiatement son utilisation, le débrancher et envoyer un e-mail au service clientèle de SAUNABOX à l'adresse [support@saunabox.com](mailto:support@saunabox.com).
- Garder tous les chiens, chats et autres animaux domestiques loin de ce produit, car il s'agit d'un appareil électrique qui peut être endommagé ou causer des blessures aux animaux.
- Ne pas utiliser ce produit avec un nourrisson, un enfant, une personne incapable ou immobile, un paraplégique ou un tétraplégique, un diabétique, une personne insensible à la chaleur ou une personne qui ne peut pas comprendre clairement les instructions et/ou utiliser les commandes.
- Ne pas utiliser en conjonction avec un autre produit chauffé électriquement.
- Ne pas replier, pincer, plier ou exposer la zone câblée de l'unité de vapeur.
- Ne pas glisser le cordon d'alimentation ou le contrôleur dans un canapé ou un autre meuble. Toutes les parties de ce produit doivent être visibles en tout temps.
- Le contrôleur n'est pas étanche à l'eau. Ne pas le plonger dans l'eau ou tout autre liquide. Le garder à l'écart des zones venteuses qui pourraient devenir humides, comme une fenêtre ouverte.
- Laisser refroidir avant de ranger et ne pas plier en plaçant des objets dessus. Le ranger dans l'emballage d'origine, dans un endroit frais, sombre et sec.
- Les bijoux en métal et autres produits peuvent devenir chauds lors de l'utilisation du sauna.
- Ne pas utiliser de crèmes analgésiques en combinaison avec ce produit chauffant.
- Éteignez et débranchez le produit chauffant lorsqu'il n'est pas utilisé.
- N'utilisez pas de produits de nettoyage corrosifs pour nettoyer le kit.
- Ne jamais laisser l'appareil branché sans surveillance.
- Débranchez l'appareil de la prise lorsqu'il n'est pas utilisé et avant de mettre ou d'enlever des pièces.
- Une surveillance étroite est nécessaire lors de l'utilisation par des enfants, des personnes invalides ou handicapées.
- Ce produit n'est pas destiné à être utilisé par des enfants sans l'approbation ou la supervision d'un médecin.
- Ne jamais utiliser l'appareil s'il présente un cordon ou une fiche endommagés, s'il ne fonctionne pas correctement, s'il est tombé ou endommagé, ou s'il est tombé dans l'eau.
- Ne pas transporter l'appareil en utilisant le cordon d'alimentation comme poignée.
- Garder le cordon éloigné des surfaces chauffées et de l'eau.
- Consulter un médecin avant utilisation si vous n'êtes pas sûr de la sécurité de l'utilisation du sauna pour vous.

## **AVANT UTILISATION, VEUILLEZ :**

- Passer en revue l'ensemble du manuel.
- Passer en revue les instructions de sécurité.
- Inspecter la surface et l'intérieur du sauna pour détecter les signes d'usure.
- Vérifier l'unité SmartSteam et le cordon pour tout effilochage et ne pas les utiliser s'ils sont présents.
- Ne pas mettre d'huiles essentielles à l'intérieur de l'unité SmartSteam, car cela peut causer des dommages.
- Se référer à la page 18 pour les instructions d'application des huiles essentielles.

## **OÙ PUIS-JE L'UTILISER ?**

- La SaunaBox peut être utilisée à l'intérieur ou à l'extérieur.
- Si vous l'utilisez à l'extérieur, il est recommandé d'avoir une couverture appropriée telle qu'une marquise, un balcon, une bâche, etc.
- Il est important de noter que la SaunaBox N'EST PAS ÉTANCHE.
- Laisser la SaunaBox à l'extérieur pendant une longue période peut causer des dommages esthétiques au sauna.

## **QUE DOIS-JE PORTER ?**

- Le port de vêtements est facultatif dans le sauna.
- L'équipe de SaunaBox recommande d'être nu avec une serviette de bain pour absorber la transpiration.
- Si vous choisissez de porter des vêtements, il est recommandé de porter quelque chose de confortable en coton ou une tenue de bain.
- Il est également recommandé d'apporter une petite serviette de main SaunaBox à l'intérieur du sauna pour absorber la transpiration.

## **PENDANT L'UTILISATION**

- **IMPORTANT :** Pour commencer, commencez au niveau 1-5 et augmentez progressivement jusqu'au niveau 6 ou 7. Le niveau 7 ne doit être utilisé QUE si vous ne transpirez pas suffisamment aux niveaux inférieurs.
- Ne dépassez pas 60 minutes à l'intérieur du sauna.
- Le contrôleur n'est pas étanche à l'eau - ne le laissez pas à l'intérieur du sauna.
- **NE PAS** ouvrir le couvercle pendant que le générateur de vapeur est en fonctionnement et laissez toujours le générateur de vapeur refroidir avant de le nettoyer ou de le toucher.
- **NE TOUCHEZ PAS** l'unité SmartSteam ou le distributeur de vapeur pendant ou après utilisation. Ils sont extrêmement chauds.
- **NE JAMAIS** déplacer le générateur de vapeur lorsqu'il contient des liquides chauds.

## **APRÈS L'UTILISATION**

- Veuillez vous référer à la page 12 pour des instructions détaillées d'entretien.
- Débranchez toujours l'appareil lorsque vous ne l'utilisez pas et avant de le nettoyer.

# INSTRUCCIONES DE SEGURIDAD IMPORTANTES

## + PELIGROS/ADVERTENCIAS

**CONSULTE A UN MÉDICO ANTES DE USARLO. ESTE NO ES UN DISPOSITIVO MÉDICO. SI TIENE ALGUNA DE LAS CONDICIONES A CONTINUACIÓN, NO SE RECOMIENDA EL USO DE LA SAUNA SIN LA APROBACIÓN DE SU MÉDICO:**

- Tiene enfermedades de la piel, quemaduras o enrojecimiento.
- Tiene enfermedades del sistema esplácnico.
- Requiere un desfibrilador cardíaco o utiliza cualquier otro dispositivo implantable.
- Tiene una enfermedad o afección cardíaca.
- Tiene huesos fracturados.
- Tiene malignidad.
- Siente náuseas, tiene dolor de cabeza u otros síntomas.
- Acaba de someterse a una cirugía.
- Tiene osteoporosis.
- Sufre de presión arterial anormal.
- Está actualmente embarazada o en período de lactancia.
- Tiene anhidrosis.
- Tiene cáncer u otras condiciones malignas.
- Tiene algún implante de metal u otro en el cuerpo, incluidos implantes mamarios.
- Tiene enfermedad mental.

**AL UTILIZAR ELECTRODOMÉSTICOS, SIEMPRE SE DEBEN SEGUIR PRECAUCIONES BÁSICAS DE SEGURIDAD PARA REDUCIR EL RIESGO DE INCENDIO, CHOQUE ELÉCTRICO Y/O LESIONES A LAS PERSONAS. EL USO INDEBIDO O EL INCUMPLIMIENTO DE ESTAS ADVERTENCIAS E INSTRUCCIONES PUEDE PROVOCAR SOBRECALENTAMIENTO, INCENDIO, LESIONES PERSONALES Y/O DAÑOS MATERIALES:**

- Asegúrese de leer todas las instrucciones cuidadosamente antes de usar este producto.
- La unidad SmartSteam puede volverse muy caliente. Colóquela sobre una superficie resistente al calor.
- Clientes de EE. UU. y CA: La sauna está diseñada para conectarse a una toma de corriente eléctrica estándar de EE. UU., Tipo B (NEMA 5), 110-120V. Asegúrese de que este producto calentado se utilice solo en un circuito de suministro de CA con la tensión adecuada. No lo use con un cable de extensión. No lo use con generadores, convertidores de energía o inversores. El uso de la sauna en otros países con transformadores eléctricos es bajo su propio riesgo.
- Clientes del Reino Unido, la UE y otros países no pertenecientes a los EE. UU.: La sauna está diseñada para conectarse a una toma de corriente eléctrica de 110-120V. No lo use con un cable de extensión. No lo use con generadores, convertidores de energía o inversores. El uso de la sauna en otros países con transformadores eléctricos es bajo su propio riesgo.

- Examine el producto, el cable y el controlador antes de cada uso en busca de signos de desgaste o daño.
- Si se observa un funcionamiento inadecuado, desgaste o daño, interrumpa su uso de inmediato, desenchúfelo y envíe un correo electrónico al servicio de atención al cliente de SAUNABOX a [support@saunabox.com](mailto:support@saunabox.com).
- Mantenga a todos los perros, gatos y otras mascotas alejados de este producto. Pueden dañar o causarles lesiones.
- No utilice este producto con:
  - Un bebé, un niño, una persona incapacitada o inmóvil.
  - Una persona parapléjica o cuadripléjica.
  - Un diabético.
- Alguien insensible al calor o que no pueda entender claramente las instrucciones y/o manejar los controles.
- No lo utilice junto con otro producto calentado eléctricamente.
- No doble, pellizque, flexione o exponga el área con cables de la unidad de vapor. No enrolle el cable de alimentación ni el control en un sofá u otro mueble. Todas las partes de este producto deben estar visibles en todo momento.
- El controlador no es resistente al agua. No lo sumerja en agua u otros líquidos. Mantenga el controlador alejado de áreas con corrientes de aire que puedan humedecerse o mojarse, como una ventana abierta.
- Permita que se enfríe antes de guardarlo y no lo doble colocando objetos encima. Guárdelo en el embalaje original, en un lugar fresco, oscuro y seco.
- Las joyas de metal u otros productos pueden calentarse al usar la sauna. No utilice este producto calentado con cremas analgésicas.
- Apague y desenchufe este producto calentado cuando no esté en uso. No utilice productos de limpieza corrosivos para limpiar el equipo.
- Nunca se debe dejar un electrodoméstico sin supervisión cuando está enchufado. Desenchúfelo de la toma de corriente cuando no esté en uso y antes de ponerse o quitarse las piezas.
- Se requiere una supervisión cercana cuando este electrodoméstico se utiliza por, en o cerca de niños, personas inválidas o discapacitadas. No está destinado a ser utilizado por niños sin la aprobación o supervisión de un médico.
- Nunca opere este electrodoméstico si tiene un cable o enchufe dañado, si no funciona correctamente, si se ha caído o dañado, o si ha caído al agua.
- No transporte este electrodoméstico por el cable de alimentación ni utilice el cable como asa.
- Mantenga el cable alejado de superficies calientes y agua.
- Hable con un médico antes de usarlo si no está seguro de si el uso de la sauna es seguro para usted.

## **ANTES DE USAR, POR FAVOR:**

- Revise todo el manual.
- Revise las instrucciones de seguridad.
- Inspeccione la superficie y el interior de la sauna en busca de desgaste y roturas.
- Verifique que la unidad SmartSteam y el cable no estén deshilachados y no los utilice si alguno de ellos está presente.
- NO COLOQUE aceites esenciales dentro de la unidad SmartSteam, ya que causará daños.
- Consulte la página 18 para obtener información sobre la aplicación de aceites esenciales. cation des huiles essentielles.

## **¿DÓNDE DEBO USARLO?**

- La SaunaBox se puede utilizar tanto en interiores como en exteriores.
- Si se utiliza al aire libre, se recomienda contar con una cubierta adecuada, como una carpa, un balcón, una lona, etc.
- La SaunaBox NO ES RESISTENTE A LA INTEMPERIE: dejarla al aire libre durante mucho tiempo puede causar daños estéticos en el sauna.

## **¿QUÉ DEBO VESTIR?**

- La ropa es opcional en la sauna.
- El equipo de SaunaBox recomienda estar desnudo con una toalla de baño para absorber el sudor.
- Si elige usar ropa, se recomienda prendas cómodas hechas de algodón o un traje de baño.
- Se recomienda llevar una toalla de mano SaunaBox dentro de la sauna para absorber el sudor.

## **DURANTE EL USO**

- Para comenzar, inicie en el nivel 1-5 y aumente gradualmente al nivel 6 o 7. El nivel 7 solo debe usarse si no se puede lograr sudoración en los niveles más bajos.
- No exceda los 60 minutos dentro de la sauna.
- El controlador no es resistente al agua; no lo lleve dentro de la sauna.
- NO abra la tapa mientras el vaporizador está en funcionamiento y siempre permita que el vaporizador se enfríe antes de limpiarlo o tocarlo.
- NO toque la unidad SmartSteam ni el dispensador de vapor durante o después de su uso. Están extremadamente calientes.
- NUNCA mueva el vaporizador mientras contenga líquidos calientes.

## **DESPUÉS DE USARLO**

- Consulte la página 12 para obtener instrucciones detalladas de mantenimiento.
- Mantenga la unidad desenchufada en todo momento cuando no esté en uso y antes de limpiarla.





**SAUNABOX.COM**  
SUPPORT@SAUNABOX.COM  
PARTNERSHIPS@SAUNABOX.COM  
COPYRIGHT © SAUNABOX.  
ALL RIGHTS RESERVED



SAUNABOX