

ASSEMBLY INSTRUCTIONS

MODEL :TB 8086

STEP 1

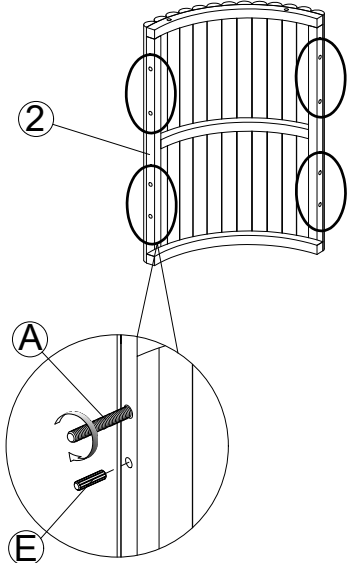

ITEM	PART NAME	QTY
1	Table Top	1 PC
2	Leg	4 PCS

ITEM	HARDWARE NAME	DESCRIPTION	QTY
A	Wood Stand M8 x 65 mm		8 PCS
B	JCBC Bolt M6 x 30 mm		8 PCS
C	Spanner		1 PC
D	Flat Washer M6x13		8 PCS
E	Wood Dowel M10x30		8 PCS
F	ALLEN KEY M4 (Long)		1 PC
G	Adjuster		8 PCS
H	Hex Nut M8		8 PCS
I	Flat Washer M8		8 PCS
J	Spring Washer M8		8 PCS

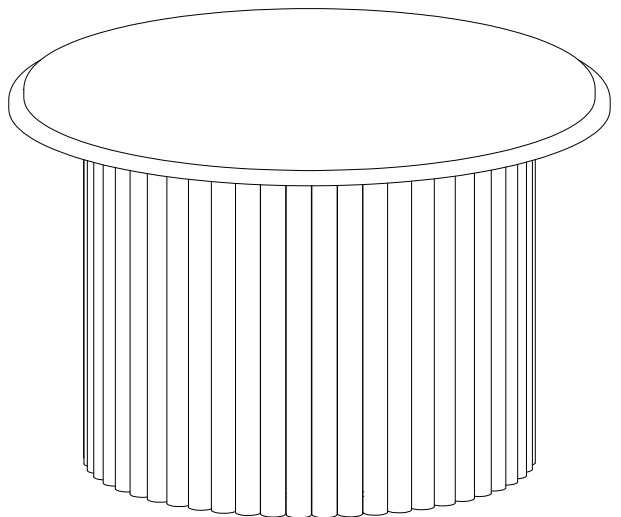

STEP 2

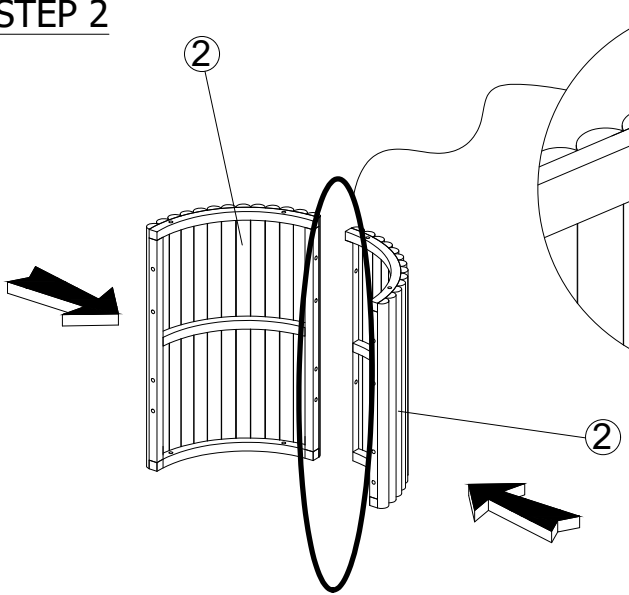

STEP 3

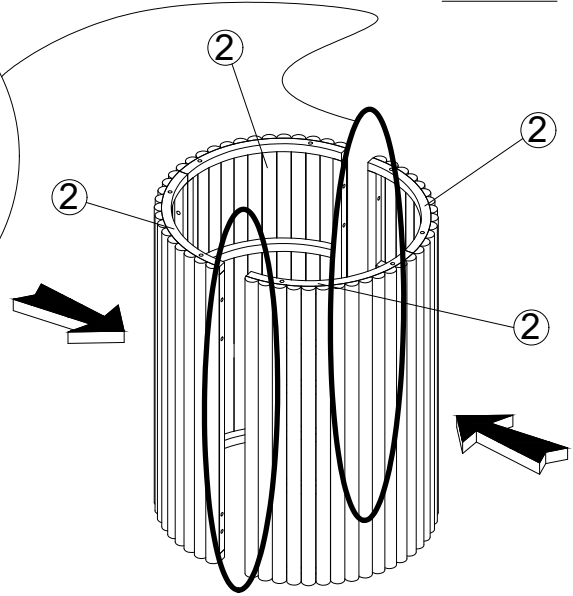

STEP 4

