

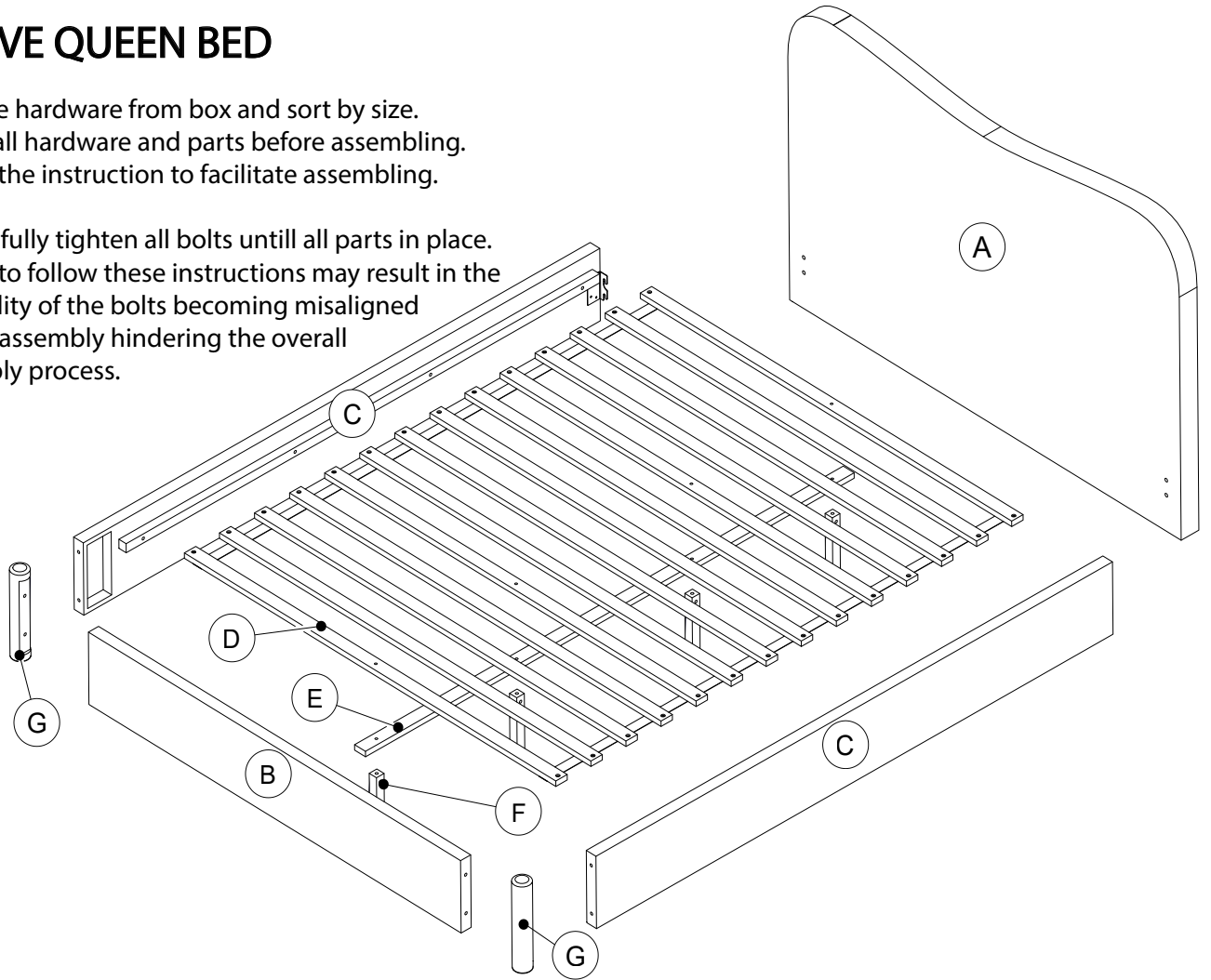







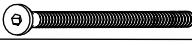

ASSEMBLY INSTRUCTIONS

#COVE QUEEN BED

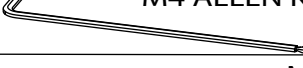

Remove hardware from box and sort by size.
Check all hardware and parts before assembling.
Follow the instruction to facilitate assembling.

Do not fully tighten all bolts until all parts in place.
Failure to follow these instructions may result in the possibility of the bolts becoming misaligned during assembly hindering the overall assembly process.

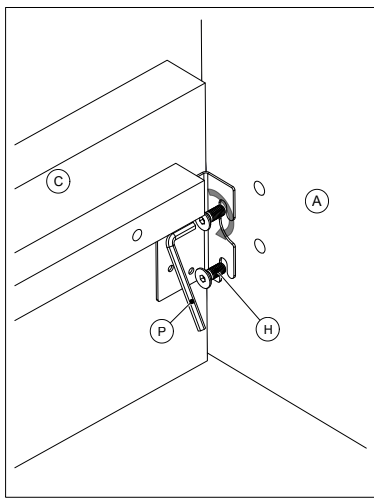

	ITEM	QTY		HARDWARE	QTY
A	HEADBOARD	1	H	 JCBB M8 X 20MM	4
B	FOOTBOARD	1	I	 JCBB M8 X 75MM	4
C	SIDERAIL	2	J	 JCBC M6 X 30MM	8
D	SLAT	1SET	K	 M6 SPRING WASHER	8
E	CENTER RAIL	1	L	 M6 FLAT WASHER	8
F	CENTER LEG	4	M	 ADJUSTER	4
G	BED LEG	2	N	 CSK M4 X 32MM	28
			O	 M4 ALLEN KEY BALL END	1
			P	 M5 ALLEN KEY	1
			Q	 BARREL NUT M8 X 20MM	4





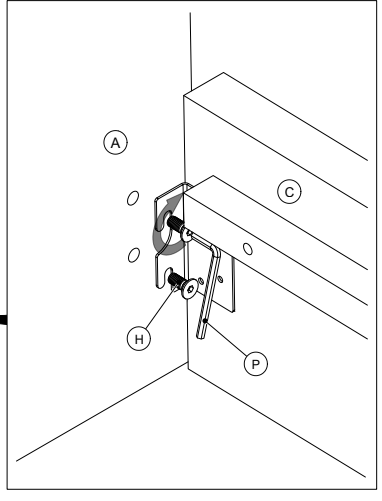
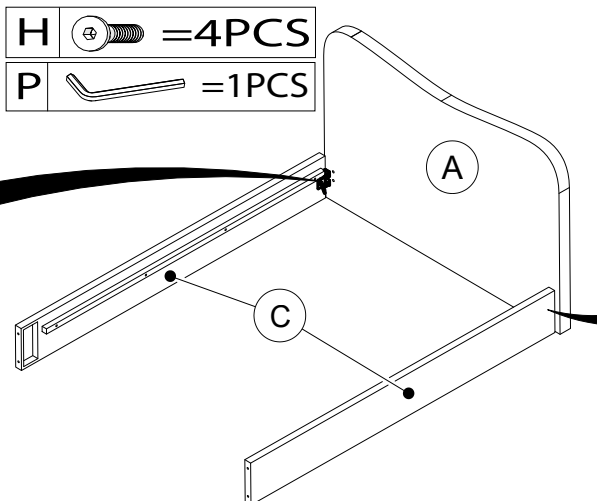

- H  =4PCS
- P  =1PCS

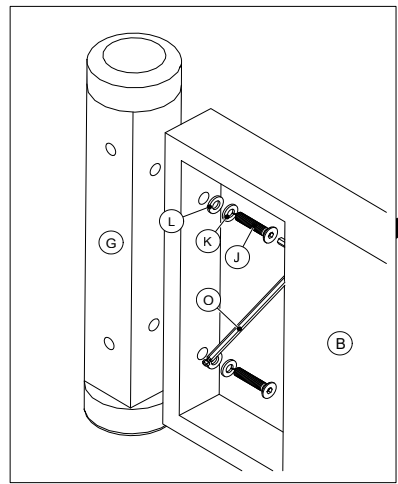

1





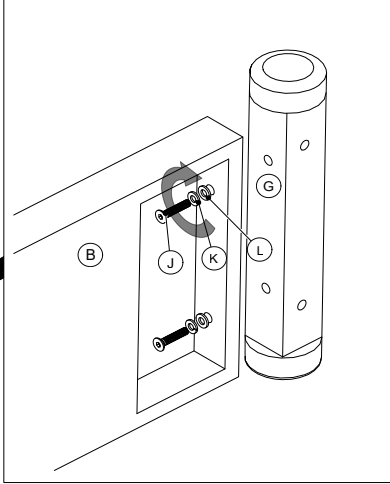
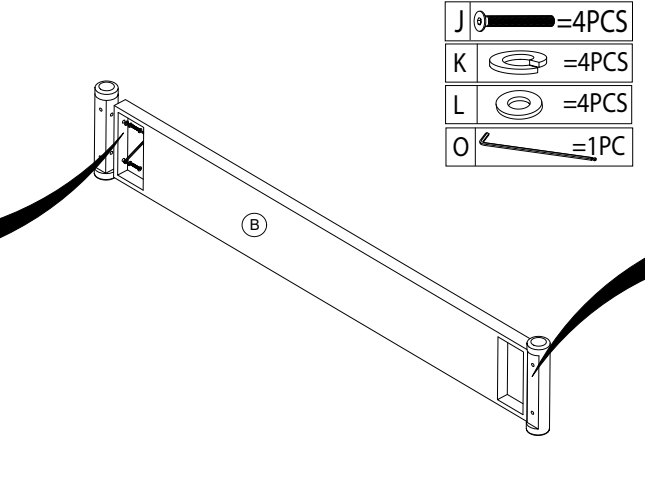

- J  =4PCS
- K  =4PCS
- L  =4PCS
- O  =1PC

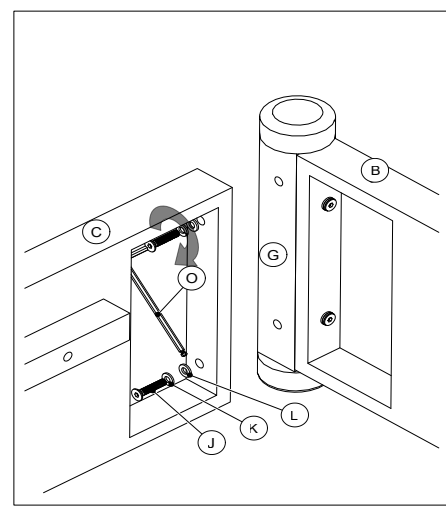

2





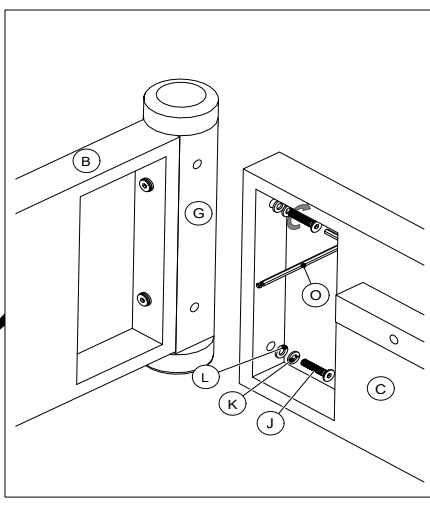
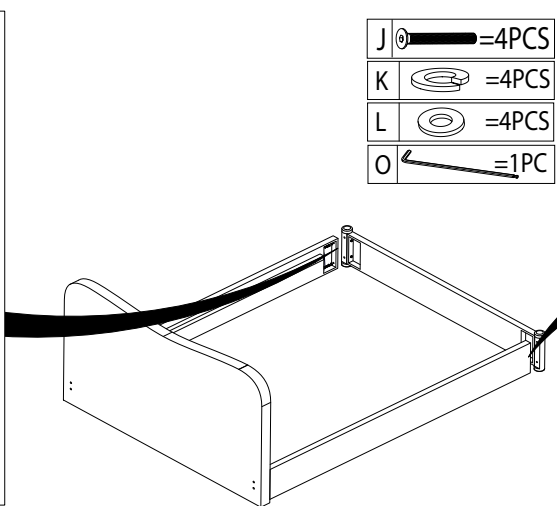

- J  =4PCS
- K  =4PCS
- L  =4PCS
- O  =1PC

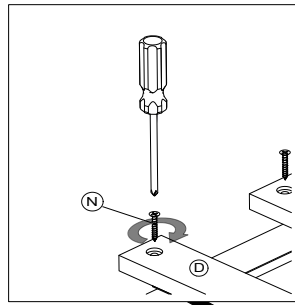
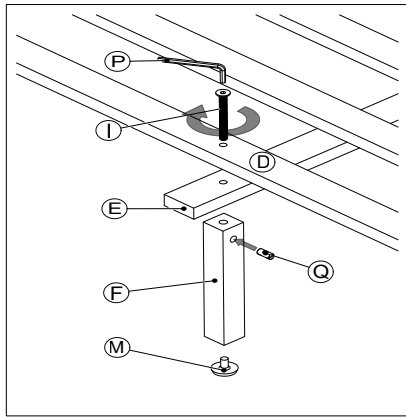

3



- Q  =4PCS
- M  =4PCS
- I  =4PCS
- P  =1PCS
- N  =28PCS

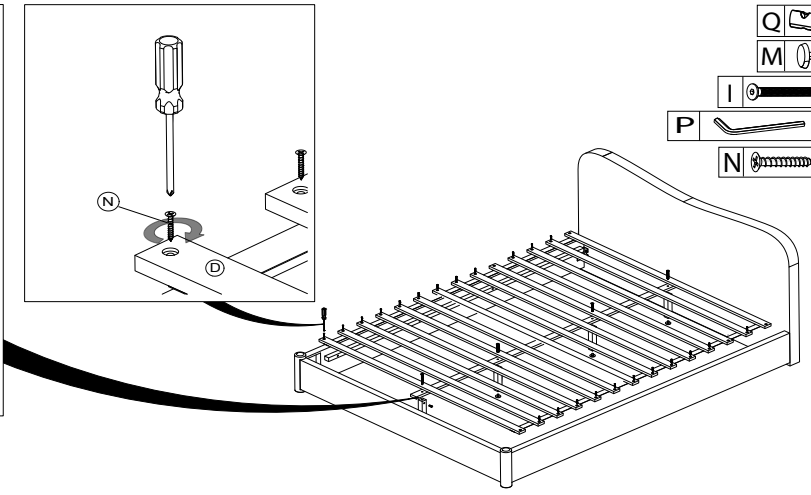

4

*Please follow AI instructions to ensure the bed is assembled correctly.