











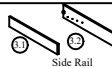















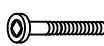



MODEL : CF 9057 - R (4'6")

Parts List		
Parts	Description	Qty
1	Headend 	1
2	Footend 	1
3	Side Rail 	2
4	Legs 100 x 45 x 90(H) 	2
5	Metal Centre Rail 1930mm 	1
6	Wooden Centre Rail 1930mm 	1
7	Support Leg 105mm 	3

Parts	Description	Qty
8	Pump Mounting Bracket 	2
9	Bracket Base 	2
10	Gas Spring 	2
11	Wooden Frame Bracket 	2
12	Wooden Frame (holes are not the same) 	1
13	Wooden Frame (holes are not the same) 	1
14	Bottom Panel 	4
15	Side Wing 	2

Hardware List		
Parts	Description	Qty
A	M6 x 30 mm JCBC 	4
B	M6 x 40 mm JCBC 	11
C	M6 x 50 mm JCBC 	6
D	M8 x 60 mm JCBB 	8
E	M6 Spring Washer 	16
F	M6 Flat Washer 	16
G	M8 Spring Washer 	16

Parts	Description	Qty
H	M8 Flat Washer 	16
I	M8 Hex Nut 	8
J	M4 x 25 mm CSK 	24
K	Allen Key M4 x 100 mm 	1
L	Allen Key M5 x 70 mm 	1
M	M8 Spanner 	1
N	Small Adjuster 	3
O	M8 x 20 mm JCBB 	8

Step 1 : Attach the pump mounting bracket (8) and bracket base (9) to the both side rail (3) using hardware parts B, E, F and K.

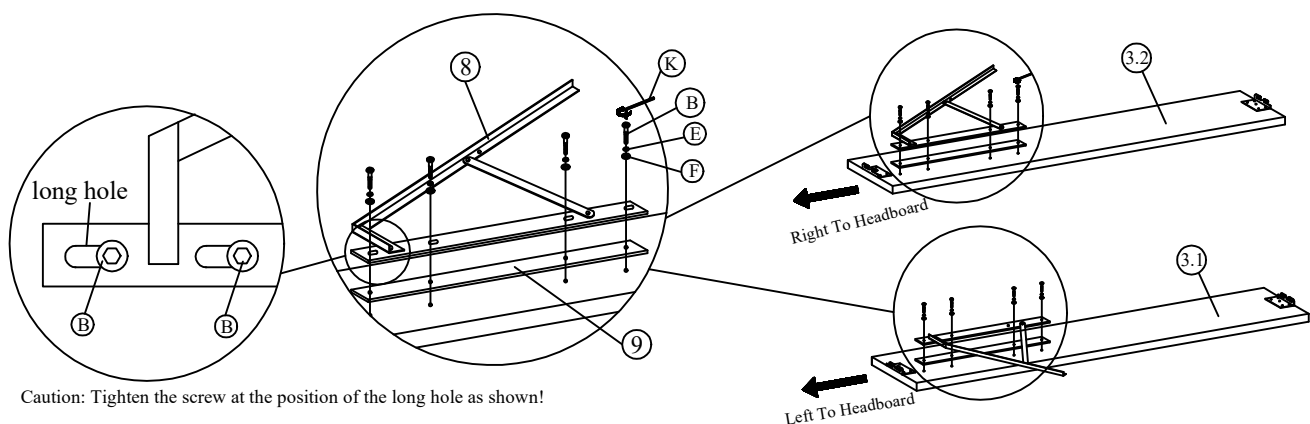

Assembly Instruction

Step 2 : Unzip the black non-woven fabric on the back of headboard and take out side wing (15) out.

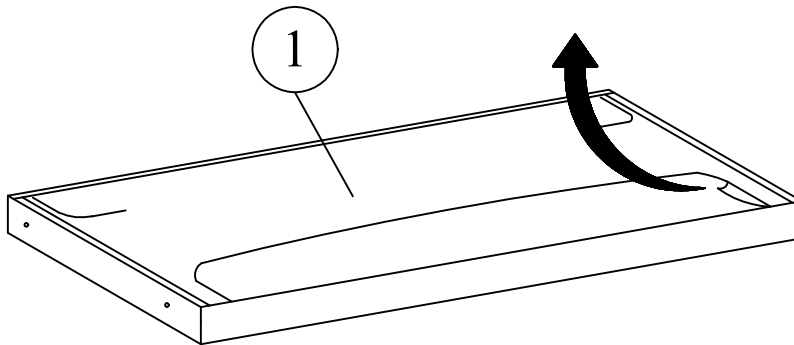

BACK VIEW

Attention: Zip the black non-woven fabric after take out the parts !!

Step 3 : Attach the legs (4) to the footend (2).

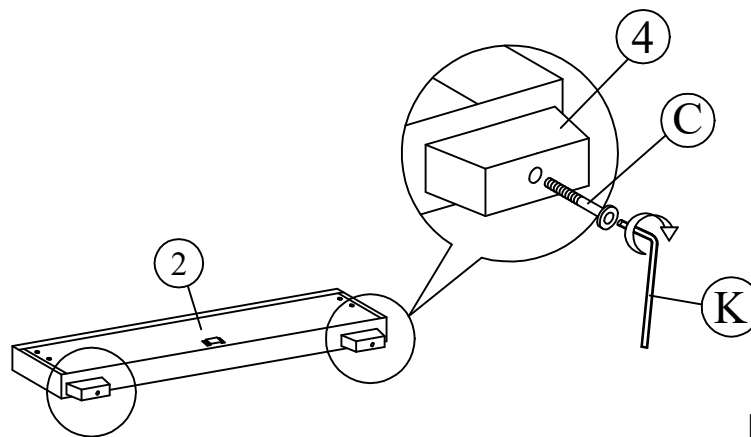

BACK VIEW

Step 4 : Attach the side wing (15) to the headend(1).

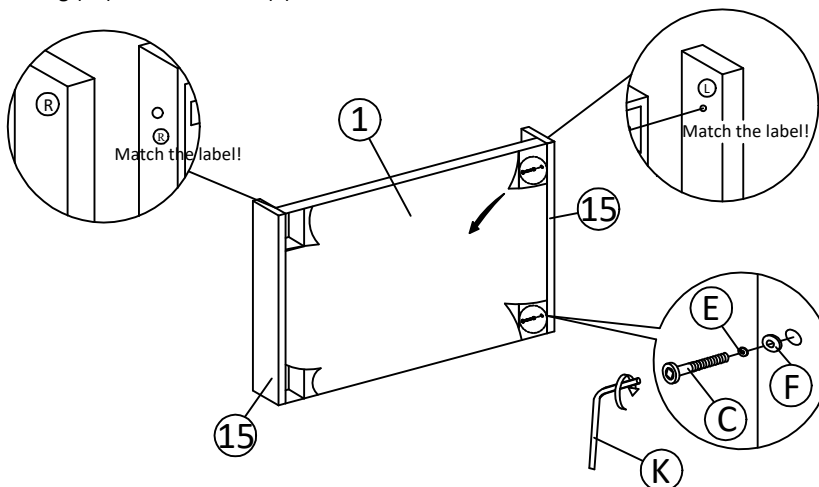

BACK VIEW

Assembly Instruction

Step 5 : Attach the side rails (3) by pushing the brackets down into place and secure the bolts using hardware part L as shown.

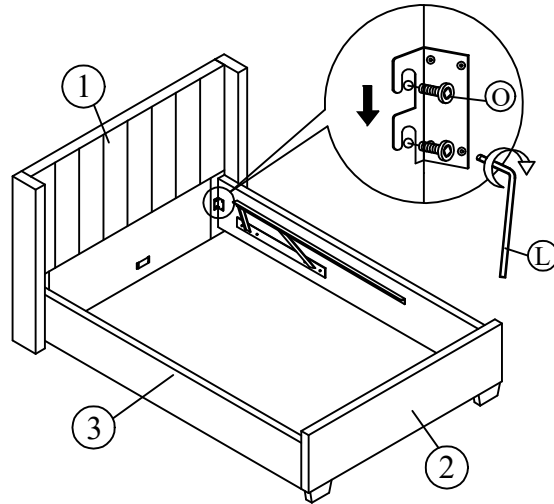

Step 6 : Attach the support legs (7) to the wooden centre rail (6) using hardware parts B and K.

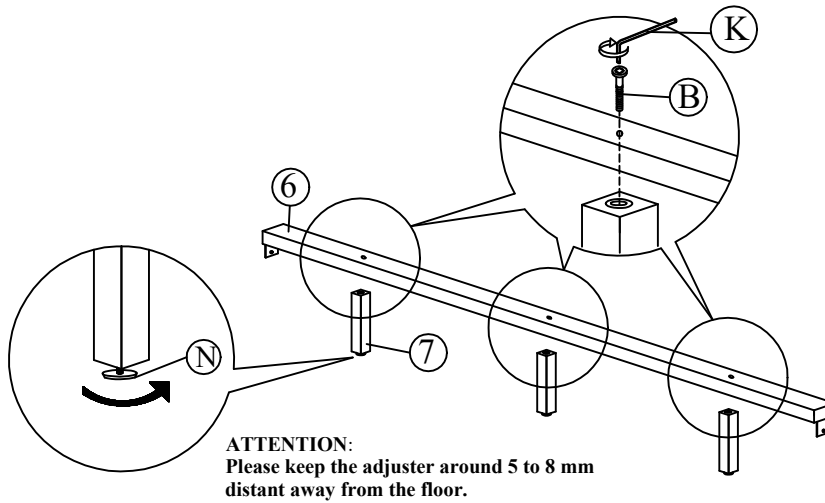

Step 7 : Insert the wooden centre rail (6) to the headend (1) and footend (2).

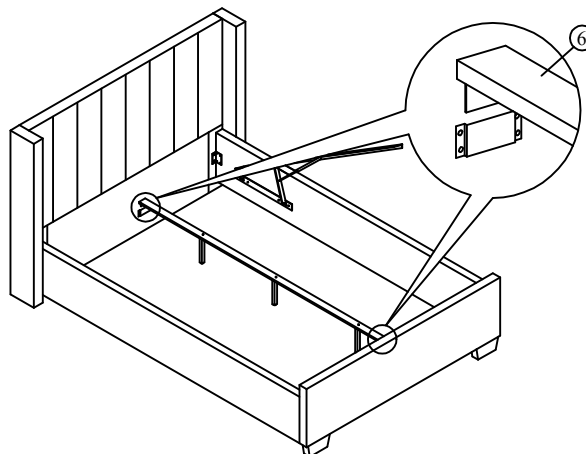

Assembly Instruction

Step 8 : Insert the bottom panel (14) to the below frame and secure using hardware part J and a screwdriver (not provided).

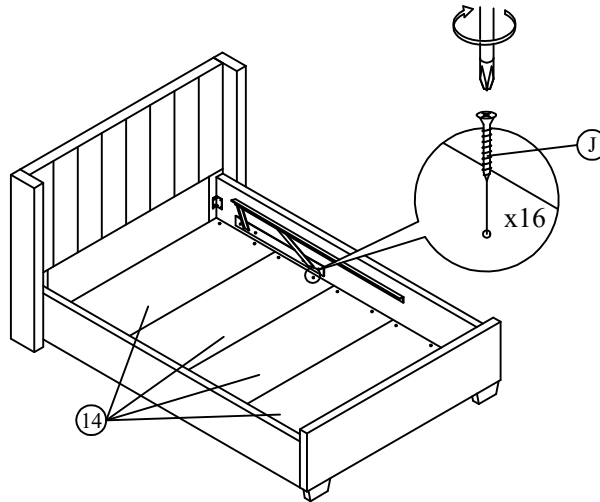

Step 9 : Insert the metal centre rail (5) to the headend (1) and footend (2) and secure using hardware part A and K.

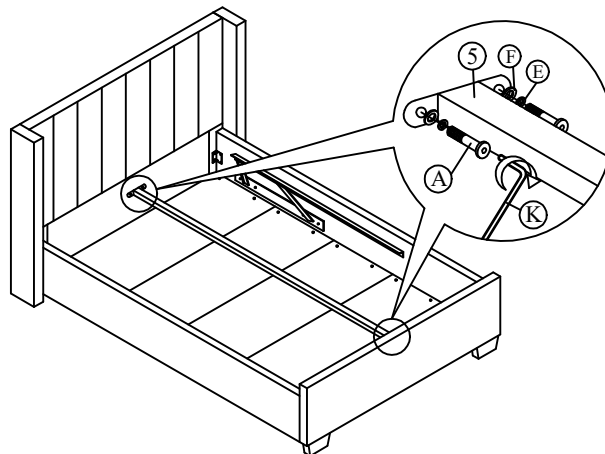

Step 10 : Unscrew the Pre-attached hex-nut of gas spring (10) and attach it back again as shown. Please fully tighten the nut.

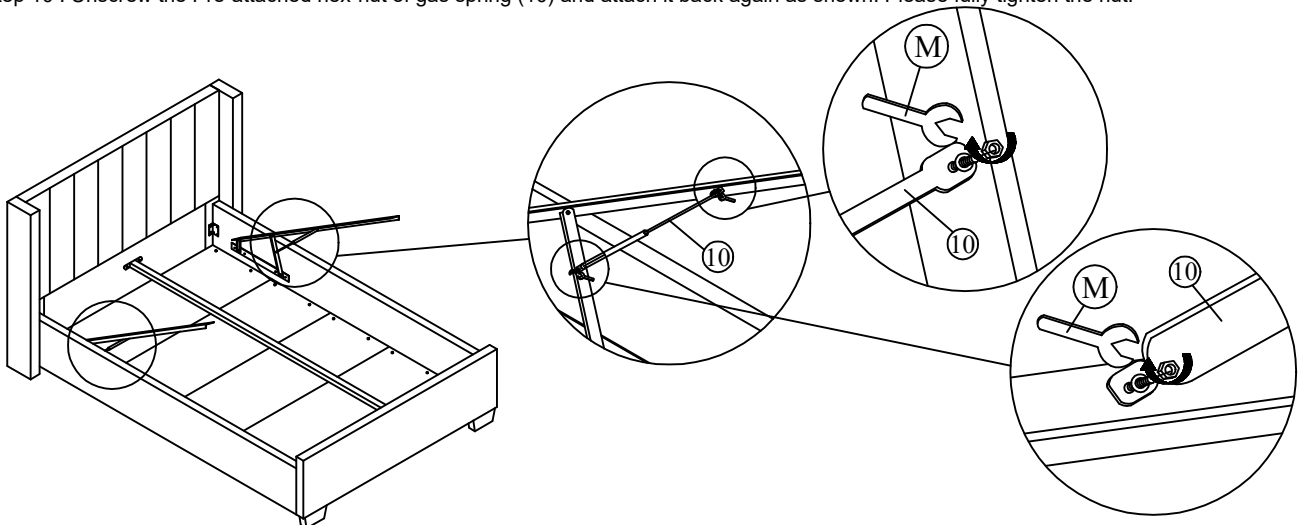

Assembly Instruction

Step 11 : Must place the wooden frame (12 & 13) in correct position (please follow the position as shown in diagram).

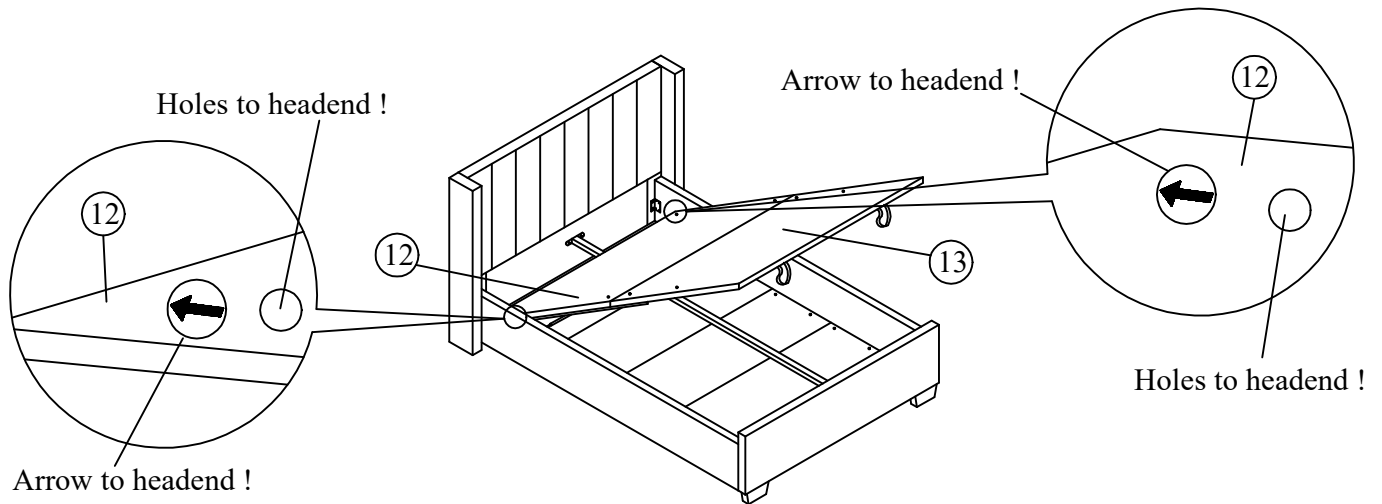

Step 12 : Assembly the wooden frame (12) and wooden frame (13) to the bracket and tighten all the fitting accordingly.

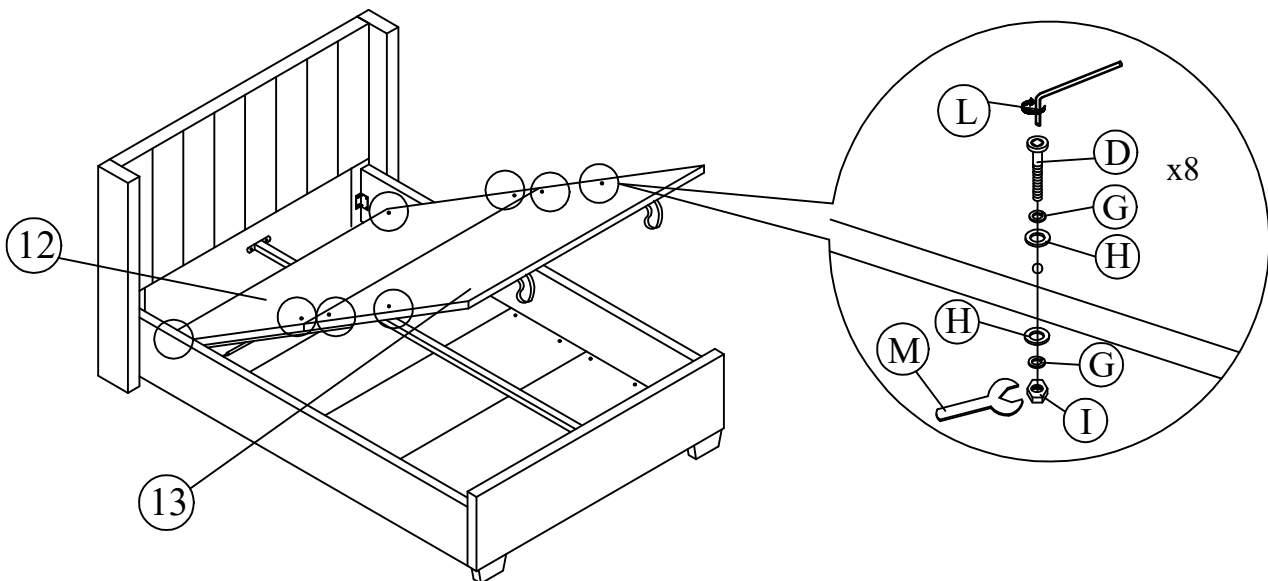

Assembly Instruction

Step 13 : Attach the wooden frame bracket (11) to the wooden frame using hardware parts J and a screwdriver (not provided).

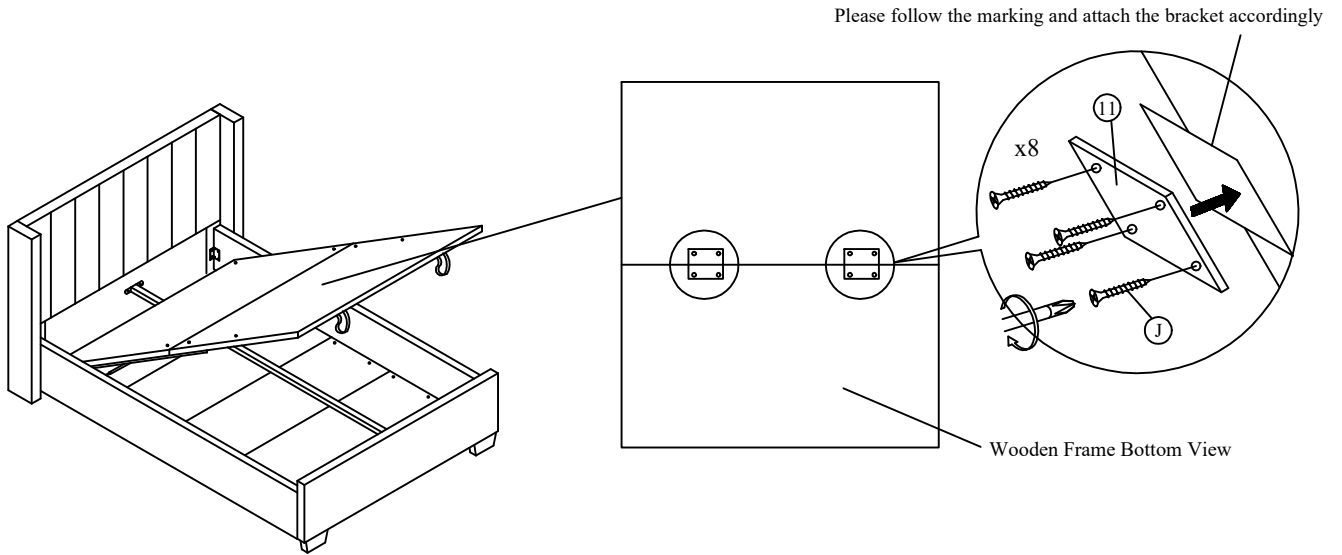

Step 14 : Please use the safety lock for safety purpose.

